

FROG-AE 8K01MI-0518



CAME 



24V SWING GATE KIT FOR A PAIR OF GATES

Up to 400kg @ 3.5m or up to 800kg @ 2m per leaf



Code	Description	Quantity
001 FROG-A24E 	Irreversible gearmotor for swing gates of up to 3.5 m per leaf, with built in adjustable opening and closing stops.	2
001 FROG-CFN	Foundation box in steel with cataphoresis treatment, complete with unlocking lever, fixing bracket to the gate and screw for adjusting the limit switch point in opening	2
ZLX24S 	Multifunctional control panel, with 230 V AC power supply, for 24 V double-leaf gates, with programming and graphical signaling display, self-diagnosis of safety devices, Adaptive Speed & Torque Technology, CXN BUS, 4 safety inputs and storage for up to 1000 users.	1
001 A4366	Release device with custom made key.	2
001 AF43S	Plug-in radio-frequency control card	1
806TS-0270	TOP44RBN - Four-channel 433.92 MHz rolling code transmitter. 4,294,967,896 combinations.	2
001 TOP-A433N	Tuned Antenna.	1
806TF-0100 	Pair of surface mounted synchronised infra-red beam BUS photocells.	1



FROG-A24E

Gate leaves of up to 1.8 m



Below-ground solution suitable for fitting to gates in single homes and apartment buildings.

- The invisible solution to power your gate.
- High degree of protection against weathering (IP67).
- System automatically resets after the gate is manually released.
- Can open up to 180° (with the FL-180 accessory).
- FROG-AE and FROG-A24E with encoder technology, tested in compliance with current regulatory standards.
- The 24 V DC versions can operate in emergency mode during power outages.
- Special steel foundation box with rustproof coating. Adjustable built-in leaf stops.

Dimensions (mm)

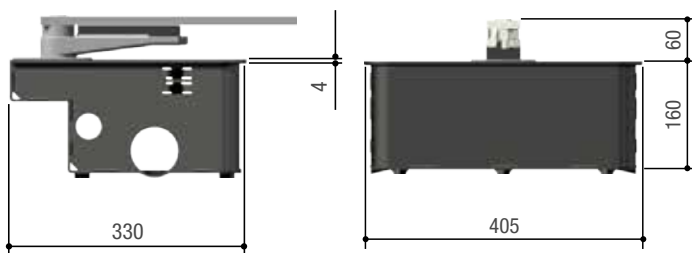

Operational limits

MODEL	FROG-A24E			
Max. width of leaf (m)	*3,5	*2,5	2	-
Max. weight of leaf (kg)	400	600	800	-

NOTES: * We suggest fitting an electric lock onto the gate leaf.

Technical characteristics

MODELS	FROG-A24E
Protection rating (IP)	67
Power supply (V - 50/60 Hz)	-
Power supply to motor (V)	24 DC
Absorption (A)	15 Max.
Power (W)	180
Maneuvering time at 90° (s)	ADJUSTABLE
Duty/cycle (%)	HEAVY-DUTY SERVICE
Torque (Nm)	320
Operating temperature (°C)	-20 ÷ +55
Motor's heat protection (°C)	-

FROG-CFN

Foundation box

Foundation box in steel with cathaphoresis treatment

- Complete with unlocking lever, fixing bracket to the gate and screw for adjusting the limit switch point in opening



Dimensions (mm)

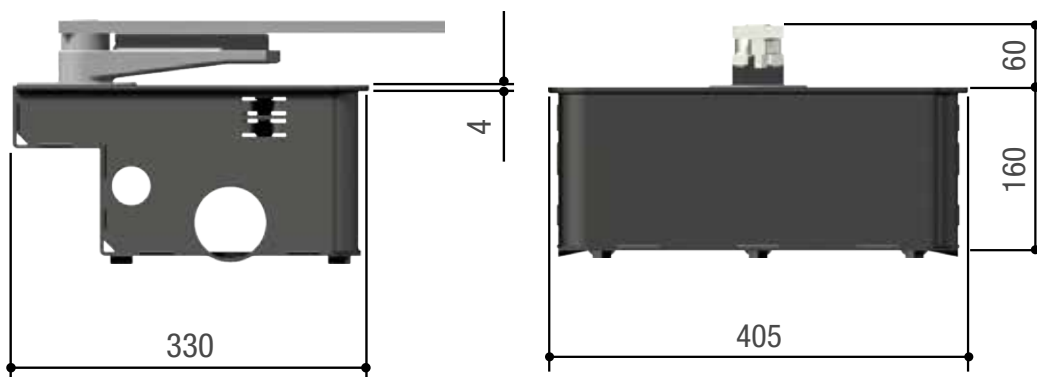

ZLX24S

Control panel



Control panel for 24V gearmotors

- Multifunction control panel for swing gates with two leaves. Graphic programming display and signalling and self-diagnostics using safety devices.

Dimensions (mm)

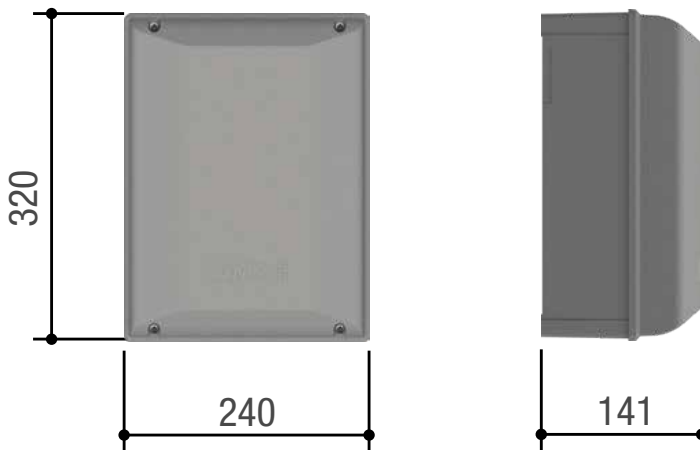

FUNCTIONS

MODEL	801QA-0060
Settable safety inputs	4
CNX BUS inputs	YES
Output B1 - B2	YES
RIO System 2.0	YES
CAME KEY and Gateway slot	YES
Adaptive Speed and Torque Technology	YES
Virtual Encoder management	YES
Users number	1000
Clock module	YES
PCB plastic cover	YES

TECHNICAL FEATURES

MODEL	801QA-0060
Protection rating (IP)	54
Power supply (V - 50/60 Hz)	230 AC
Operating temperature (°C)	-20 ÷ +55
RAL color	7024
Cabinet material	ABS

- 24 V DC

A4366

Mechanical release device



Mechanical release device with custom made key for Frog motor.

- Unlocking mechanism;
- Custom-made unlocking key;
- 4 M8 x 30 cheese headed hexagonal socket screws.
- 4 safety lock washer.

Fig. 1

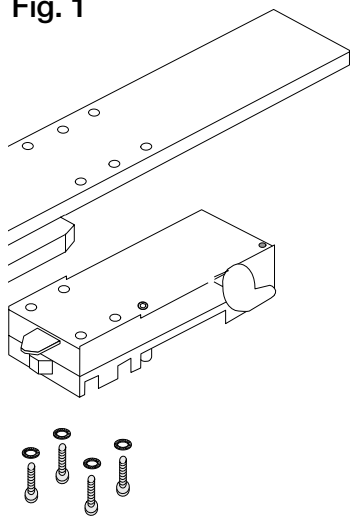

Fig. 2

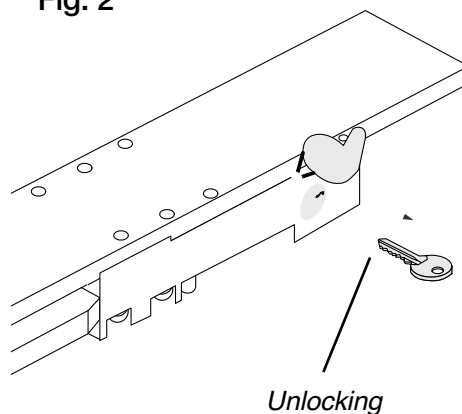
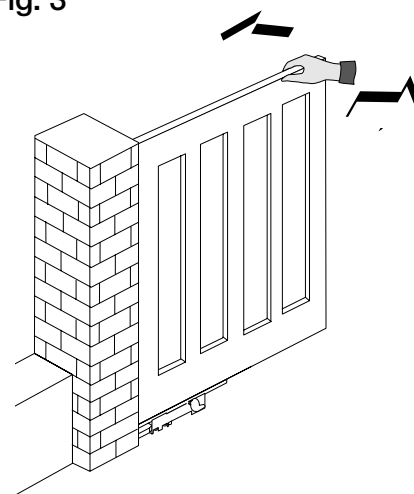

Fig. 3



ACCESSORIES

TOPA433N

Tuned Antenna for 433.92Mhz



Dimensions (mm)

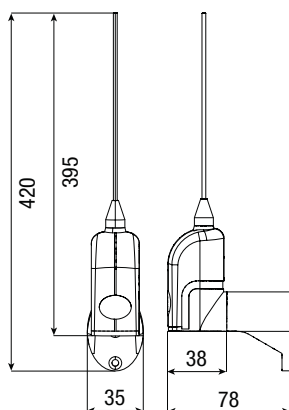

Operational limits

MODELS	TA433N
Max. range of radio (m)	50 ÷ 150

Technical characteristics

MODELS	TA433N
Radio signal frequency (Mhz)	433.92Mhz

AF43S

Radio frequency control card 433.92MHz



- Dip-switches for code and function selection
- Function enabling button
- Red signalling LED
- Green signalling LED
- Backup board
- Plug-in connector on receivers

Technical characteristics

MODELS	AF43S
Power supply (V±10%)	5
Current draw (mA)	5.5
Encoding type	ASK
Operating temperature (°C)	-20 to +55
Sensitivity (dBm)	-107

TOP44RBN

Rolling code 433.92 radio control



- Self-learning from transmitter to transmitter.
- Self-learning from TOP, TAM and TWIN series radio controls.
- More secure thanks to the dynamic code for the rolling code version.
- It can be configured remotely via gateway or locally via GAME KEY.

Dimensions (mm)

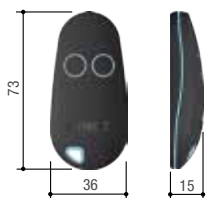

Operational limits

MODELS	806TS-0270
Max. range of radio (m)	50 ÷ 150

Technical characteristics

MODELS	806TS-0270
Combinations	4.294.967.896
Radio signal frequency (Mhz)	433,92
Operating temperature (°C)	-20 ÷ +55
Material	POLYCARBONATE

DLX BUS

Photocells



- Control the gate's area of movement
- It can synchronize up to eight pairs of photocells, with no disturbances, plus no wiring required between the transmitter and the receiver.
- Adjustment of the infrared beam range from 10 to 30 meters.
- Filter function to prevent false detections due to bad weather or direct sunlight.
- Settable contact output so the photocell can double as a control device.
- Alignment function between transmitter and receiver.

Dimensions (mm)

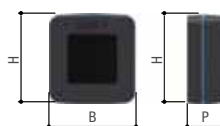

Operational limits

MODELS	806TF-0100
Max. range of radio (m)	30

Technical characteristics

MODELS	806TF-0100
Protection rating (IP)	54
Power supply (V)	CXN BUS
Absorption	-
Max. rating of 24 V (A) relay contacts	-
Operating temperature (°C)	-20 ÷ +55
Material	ABS – ALUMINIUM