

HINDI 880 SPRINT

➤ OIL-HYDRAULIC OPERATOR
FOR DOUBLE SWINGING GATES



INSTALLATION MANUAL

IN CONFORMITY TO EN 12453, EN 12445 SAFETY STANDARDS

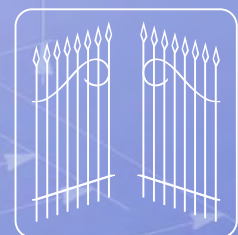

FADINI[®]
the gate opener
Made in Italy

HINDI 880 SPRINT OIL-HYDRAULIC OPERATOR FOR SWINGING GATES

- RECOMMENDED GATE WIDTH 1.80 m PER LEAF

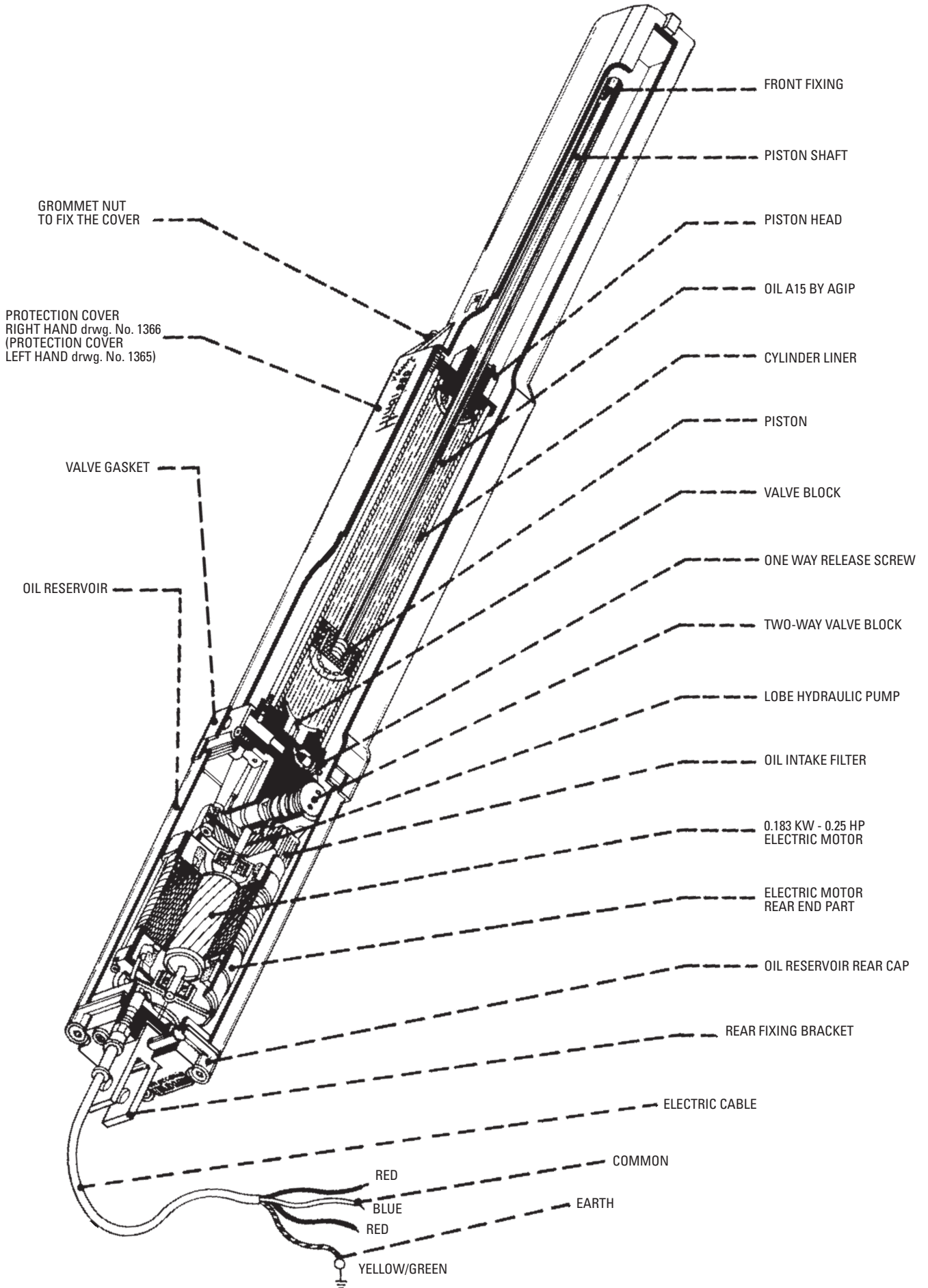

PIC. 1

HINDI 880 SPRINT is an oil-hydraulic operator of new construction principles and provides an extremely versatile system for the automation of swinging gates. Fixing is by plates and bolts. One plate to the gate and one to the gate post. (Pic. 2).

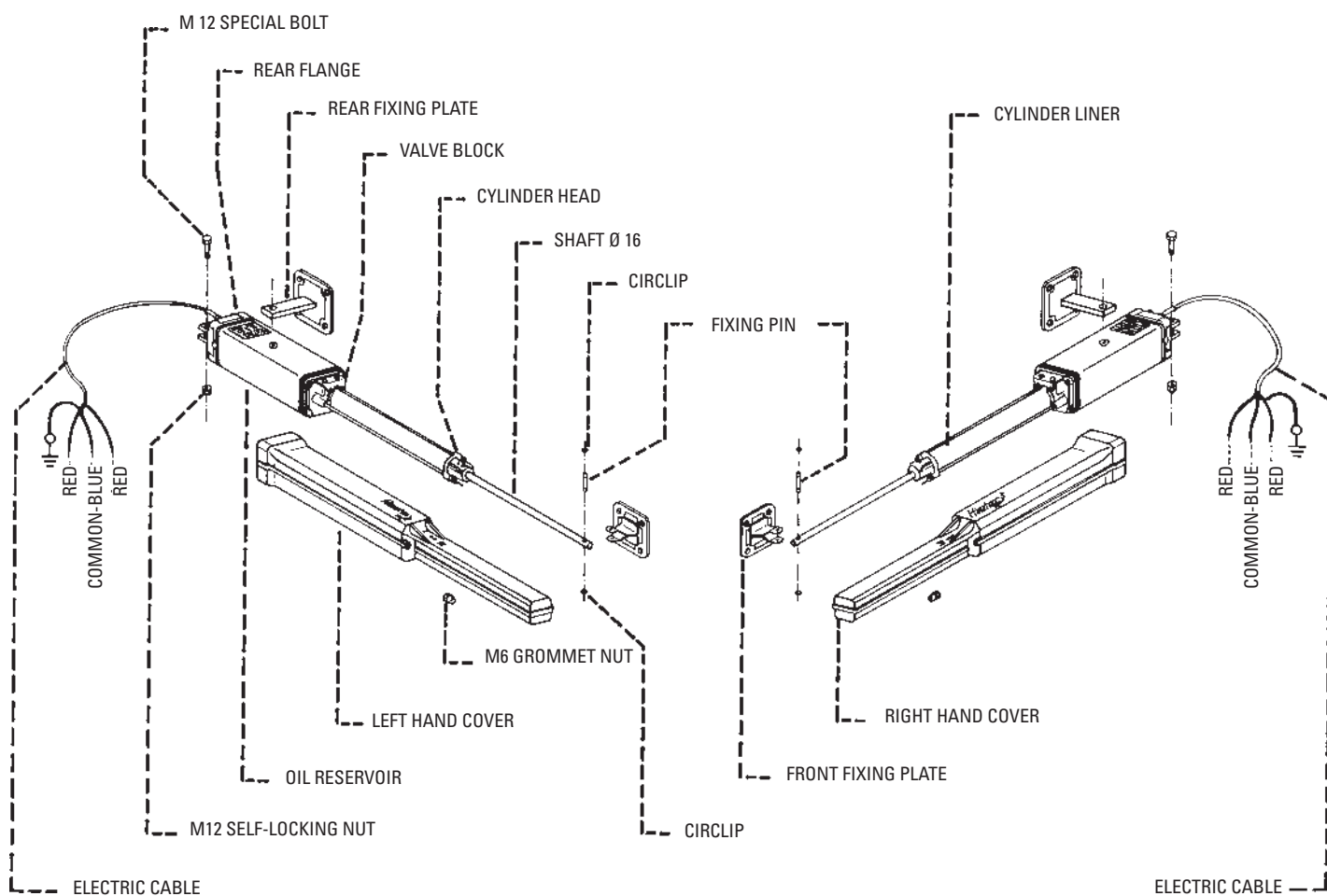

➤ **PIC. 2**

FITTING HINDI 880 SPRINT TO A DOUBLE SWINGING GATE

It is recommended to keep to the instructions below to achieve perfect performance of the equipment.

The operator is factory-filled with special oil which ensures the perfect performance of the arm in the most harsh weather conditions within a temperature range from -25°C up to $+80^{\circ}\text{C}$ (Pic. 1).

HINDI 880 SPRINT is entirely made of pressure cast aluminium parts by MECCANICA FADINI. Each unit is tested individually to ensure reliability for a long time.

Before installing HINDI 880 SPRINT check if the structure of the gate is adequate to take the operator and be electrically operated. A well built and smooth gate without any friction is essential to a perfectly working system. If necessary, reinforce the gate and make it as smooth as possible (specially check the hinges) by eliminating any possible friction against the gate post and pavement.

HINDI 880 SPRINT is designed to be fixed to the gate post by means of specially designed plates. It is essential to keep to the fixing measurements illustrated below from hinge centre to centre line of rear fixing bolt. Do not fix the front bracket until satisfied that the operator is aligned. Provide a temporary set up by means of a clamp to hold the bracket, and do the first tests. The shaft must be fully out 250 mm measured from the end part of the cylinder to the centre of the front fixing pin. (Pic. 3).

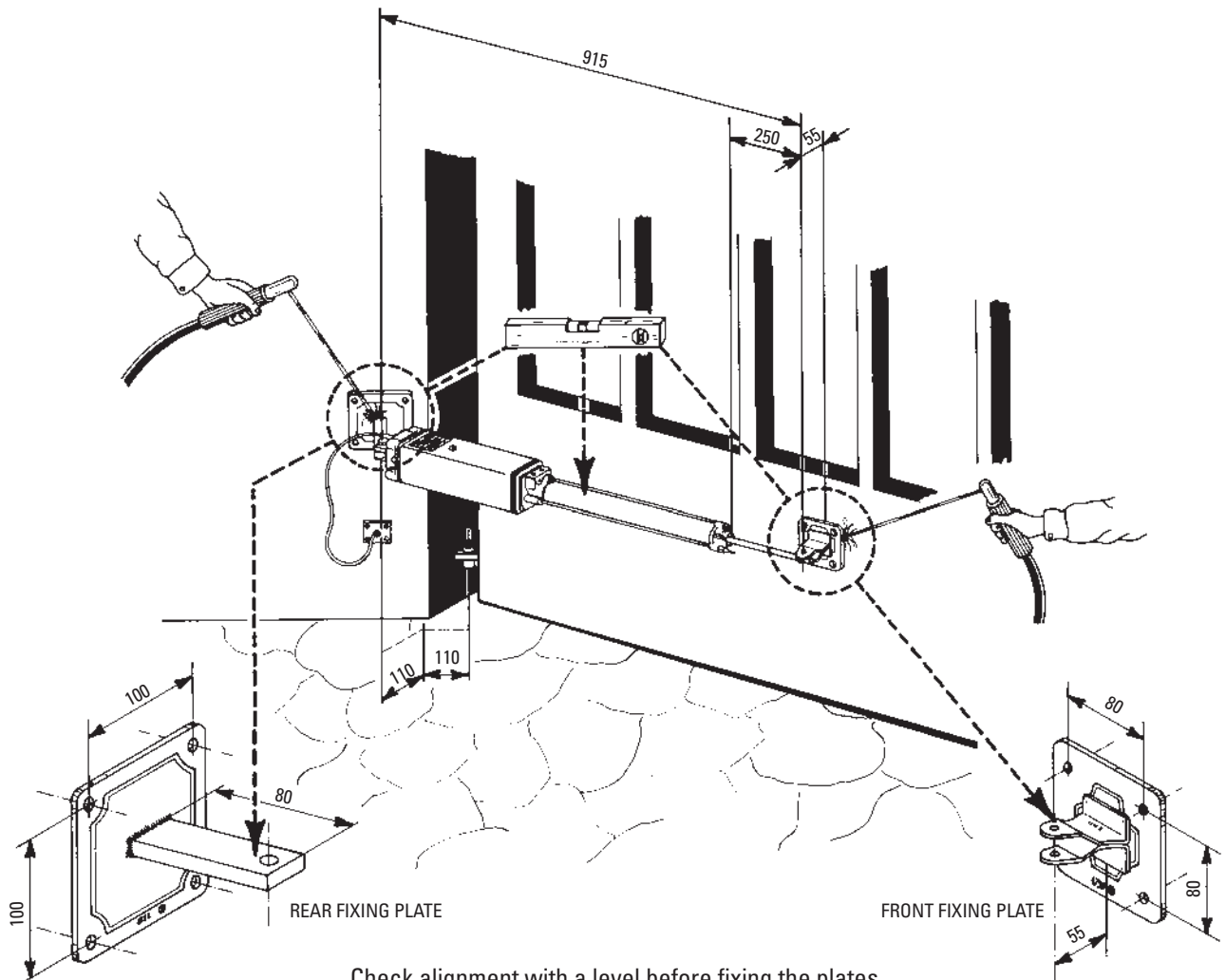

Check alignment with a level before fixing the plates
Temporary set up for first tests

➤ **PIC. 3**

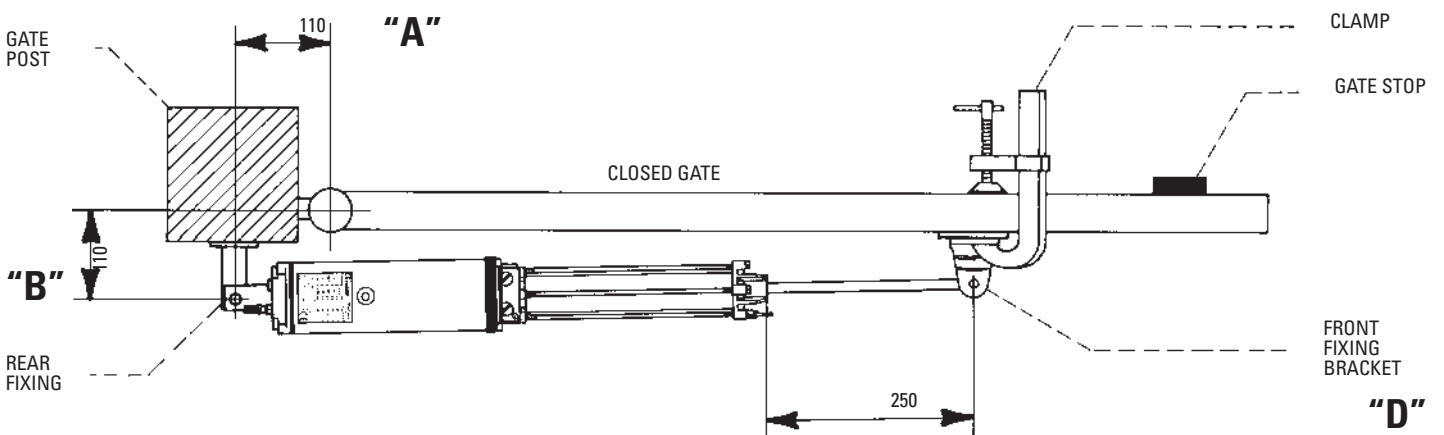

➤ **PIC. 4**

IMPORTANT: DURING THE FIRST TESTS VERIFY THE COMPLIANCE WITH MEASUREMENTS ON PAGE 5.

Fixing dimensions of the rear fixing plate as quoted in the below drawing. (Pic. 5).

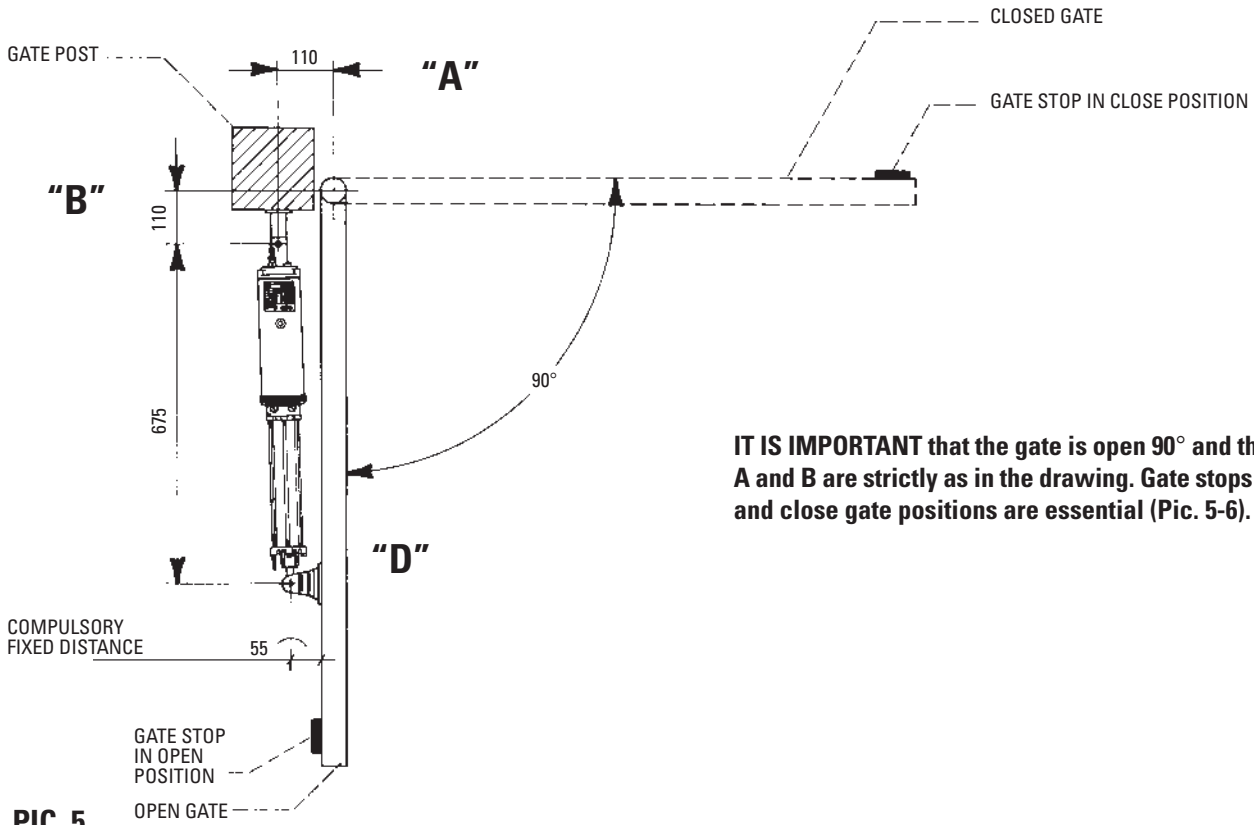

IT IS IMPORTANT that the gate is open 90° and that the distances **A** and **B** are strictly as in the drawing. Gate stops both in the open and close gate positions are essential (Pic. 5-6).

PIC. 5

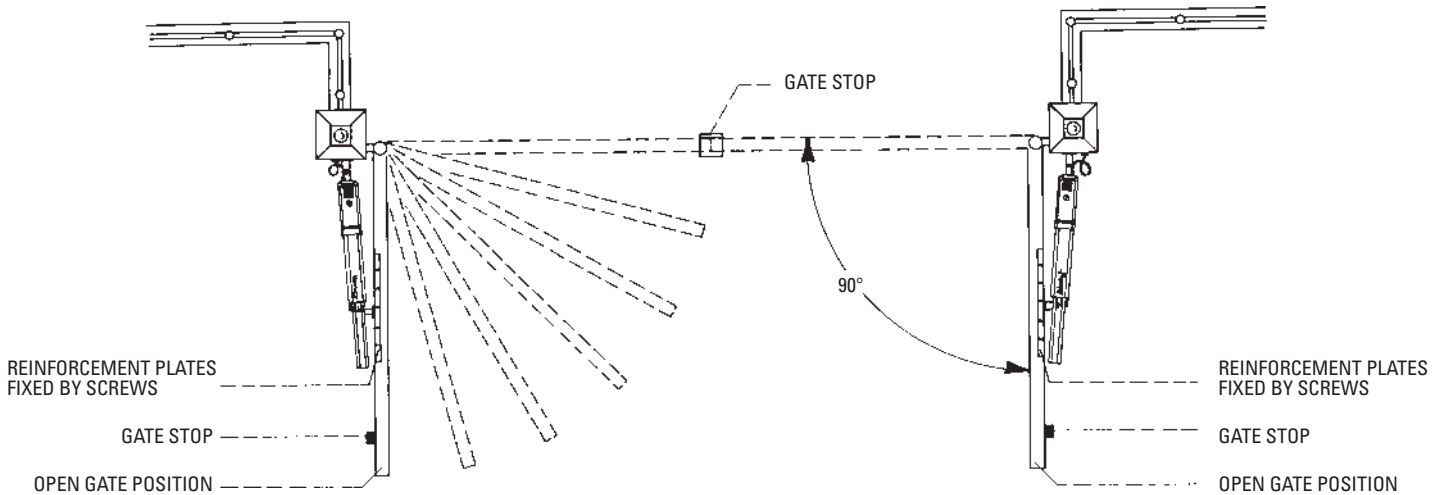

PIC. 6

In case the gate is made of light aluminium or wood, it is recommended to reinforce it with metal plates so that the front bracket, with its own reinforcing plate, can easily be welded to the gate or screwed up to it by 4 screws type M 8. Where brick piers are involved and the gates prehung or the gate hinges are mounted in the middle of the pier, there may be brickwork to cut out in order to allow clearance for the operator between the pier and the gate in the open position. The fixing distances are always to be referred to the centre of the gate hinge and rear lock nut and bolt pivot of the operator. See below (Pic. 7 and 8).

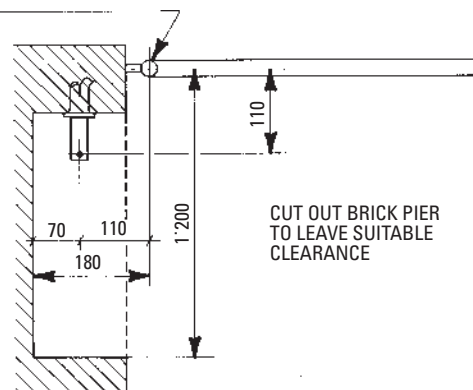
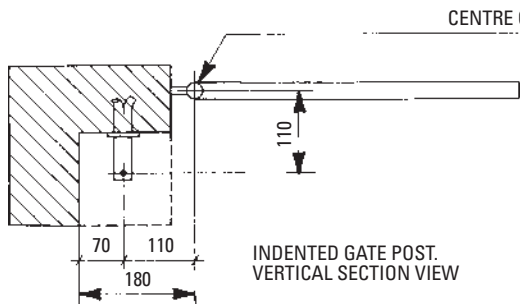

PIC. 7

PIC. 8

MANUAL FIRST RUN TEST. METHOD A OR B

A qualified technician is recommended. (The manufacturer declines any responsibility for this operation).

A) The following will explain how to carry out the first manual test to make sure the operator is working properly. You need a 2 wire cable fitted with an electric plug and a 12 μ F capacitor. Connect the capacitor to the red wire No.2 or No.3 as shown in the drawing. Supply power to the motor through wire No. 1. The second wire is to be connected to red No.2 and then red No.3 respectively for 18 seconds. The operator will perform a complete cycle: fully out and fully in. (Pic. 9). Make sure the circuit is properly earthed through wire "M".

B) Temporarily connect the operator to the control panel (Pic. 16). Connect mains supply to terminals 24, 25. Connect earth wires together. Link out all N/C TERMINALS 1, 2 photocells; 6, 8 STOP separately. Set DIP switches 1 to 4 to desired operation. Set timers 7, 8, 9. With link wire touch on 3, 4 for open and 3, 5 for close. (Note: should safety contact exist 14, 15 should be linked out). VALVE "A" OPEN MUST BE SET AT A HIGHER PRESSURE THAN VALVE "C". (Pic. 10).

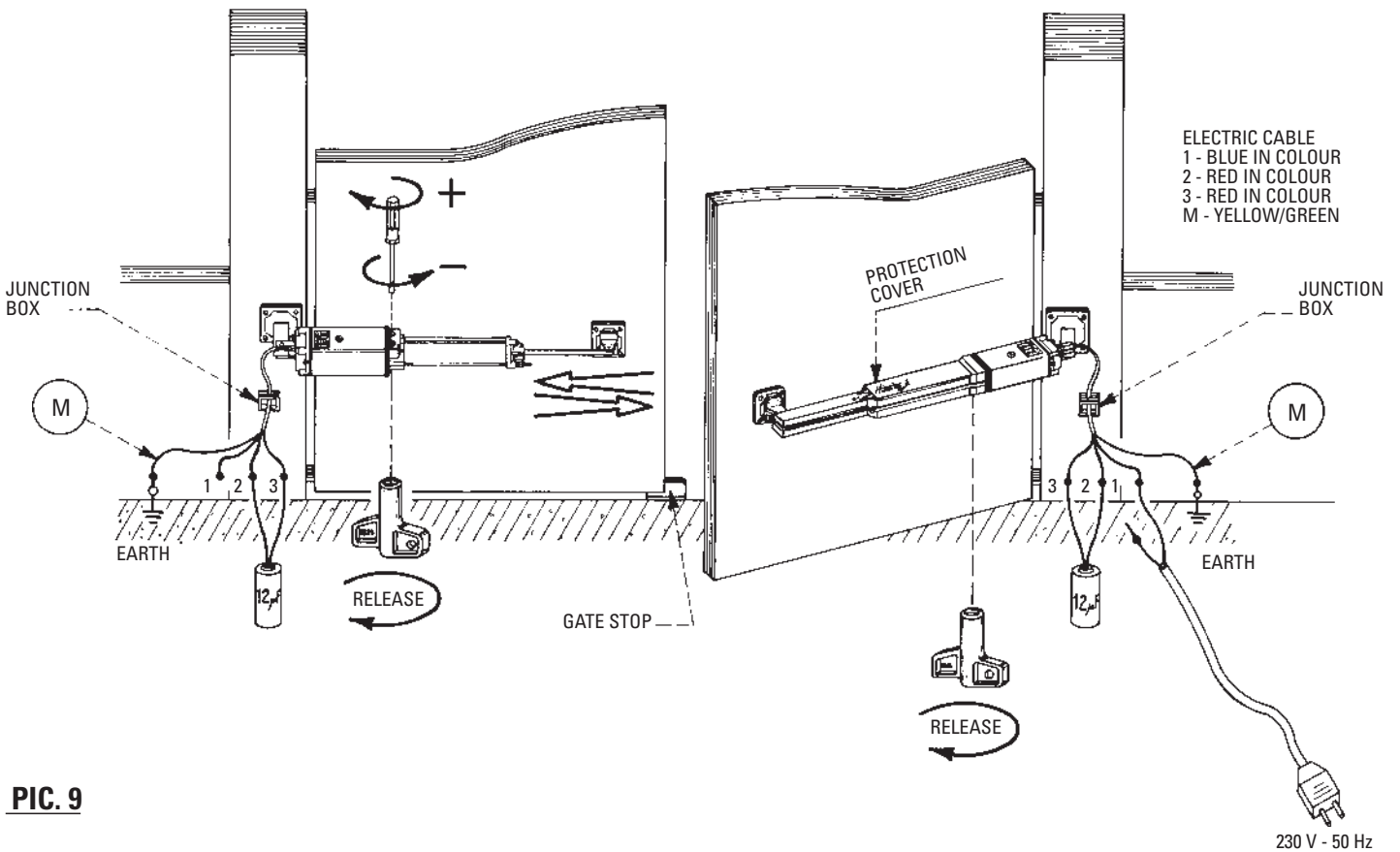

➤ **PIC. 9**

Please note: The OPEN pressure must be set higher than the close pressure. Turn screw "A" until it is visually lower than "C" CLOSE, otherwise the operator may loose power and fail to open. (Pic. 10).

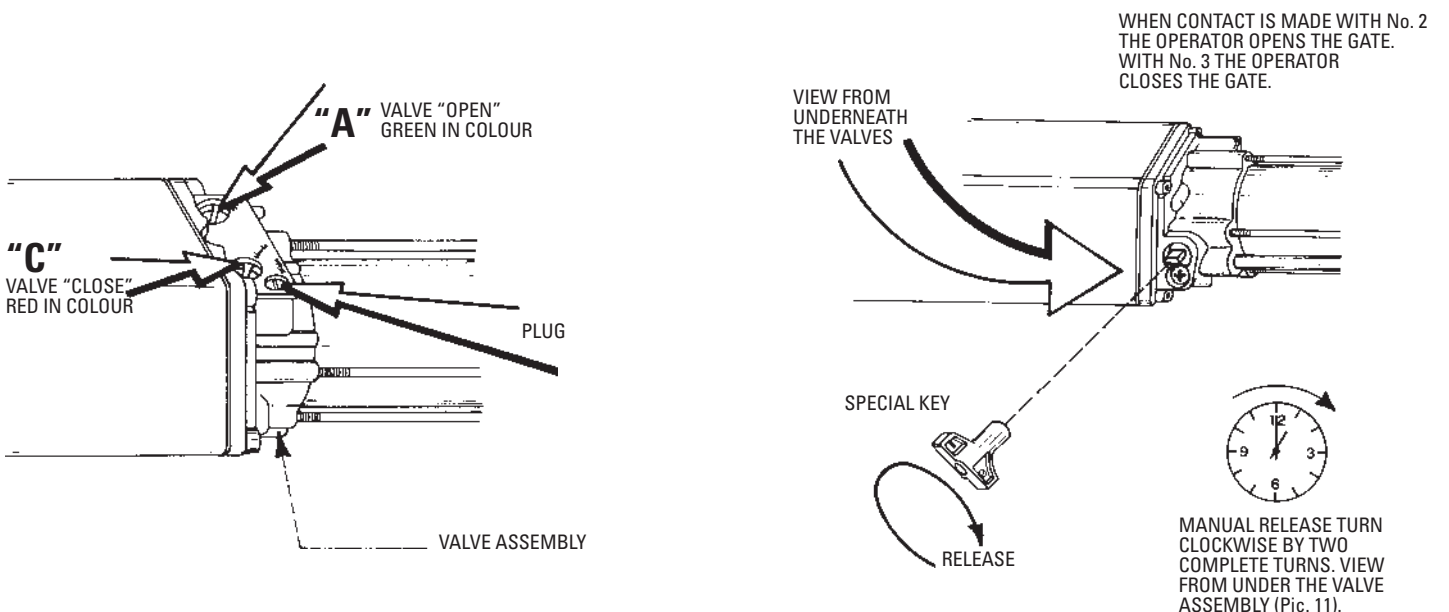

➤ **PIC. 10**

PIC. 11 ◀

For safety reasons (anti-crush) it must be possible to stop the gates by hand pressure, which is ensured by the pressure safety valves. Once set so that an adequate amount of thrust power is achieved, they will retain their status in a stable way for very long time, thanks to their accurate engineering design. For security reasons they are incorporated under the cover to prevent misuse. (Pic.9). The model with hydraulic locking device is recommended for gates up to 1.8 m per leaf. No electric lock is necessary, the gate is held in closed position by the hydraulic locking valve. (Pic. 12). For gates wider than 1.80 m it is recommended to install the non-locking operators and fit the gates with an electric lock.

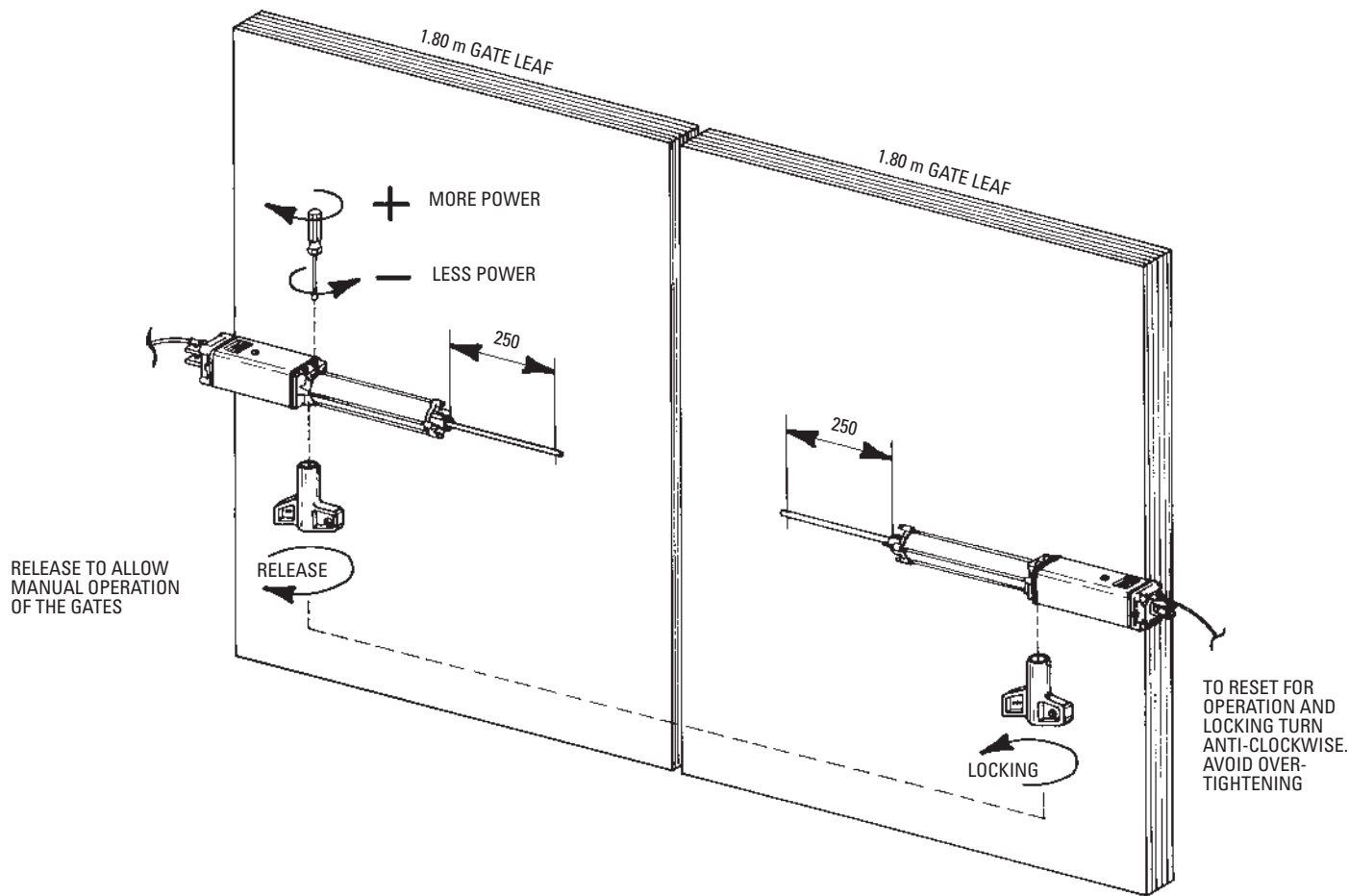

➤ **PIC. 12**

During the first running tests adjust the pressure safety valves "A" OPEN and "C" CLOSE. These are located in the mid-section of the operator. (Pic. 10).

The locking model can be recognized as it has a "release tap" on the side opposite to the pressure valves, underneath the operator (Pic.11). Two turns clockwise are required to release the hydraulic circuit. This operation is to be carried out by means of the supplied key. After releasing the operator, the gate can be pushed open by hand. Tighten the screw thoroughly before recycling, but avoid overtightening. The hydraulic circuit is now back to locking condition. (Pic. 11).

Maximum recommended gate width: 1.8 m per leaf.

Important: the open pressure must be set higher than the close pressure. Turn screw "A" until it is visually lower than "C" by two turns. This will give more required power in the open cycle (Pic. 10).

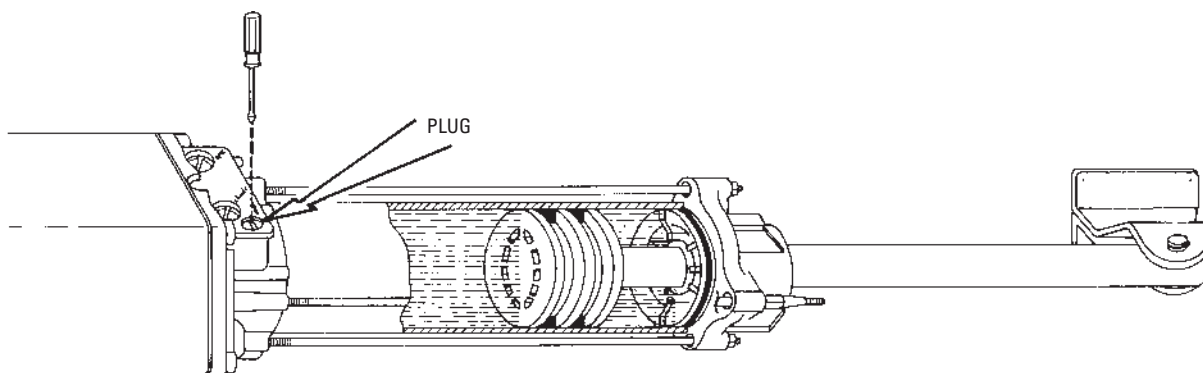

➤ **PIC. 13**

Now the electrical work. Connections are as per the diagram on the next page, Elpro 13 exp (Pic. 16 and 17).

Once connections have been made, adjust the switches in the control box so that the sequence of operations occurs as pre-set. If any leaf delay is required, check that it occurs correctly. Set DIP switch 3 on automatic and check if the working period meets your requirements. Adjust the motor run timer 9 to give 2 seconds over run time against ground stops in both open and close positions. On semi-automatic mode, DIP-switch B No.3 OFF, one pulse opens the gates, a second pulse is needed to close the gates. (See B, pic. 16).

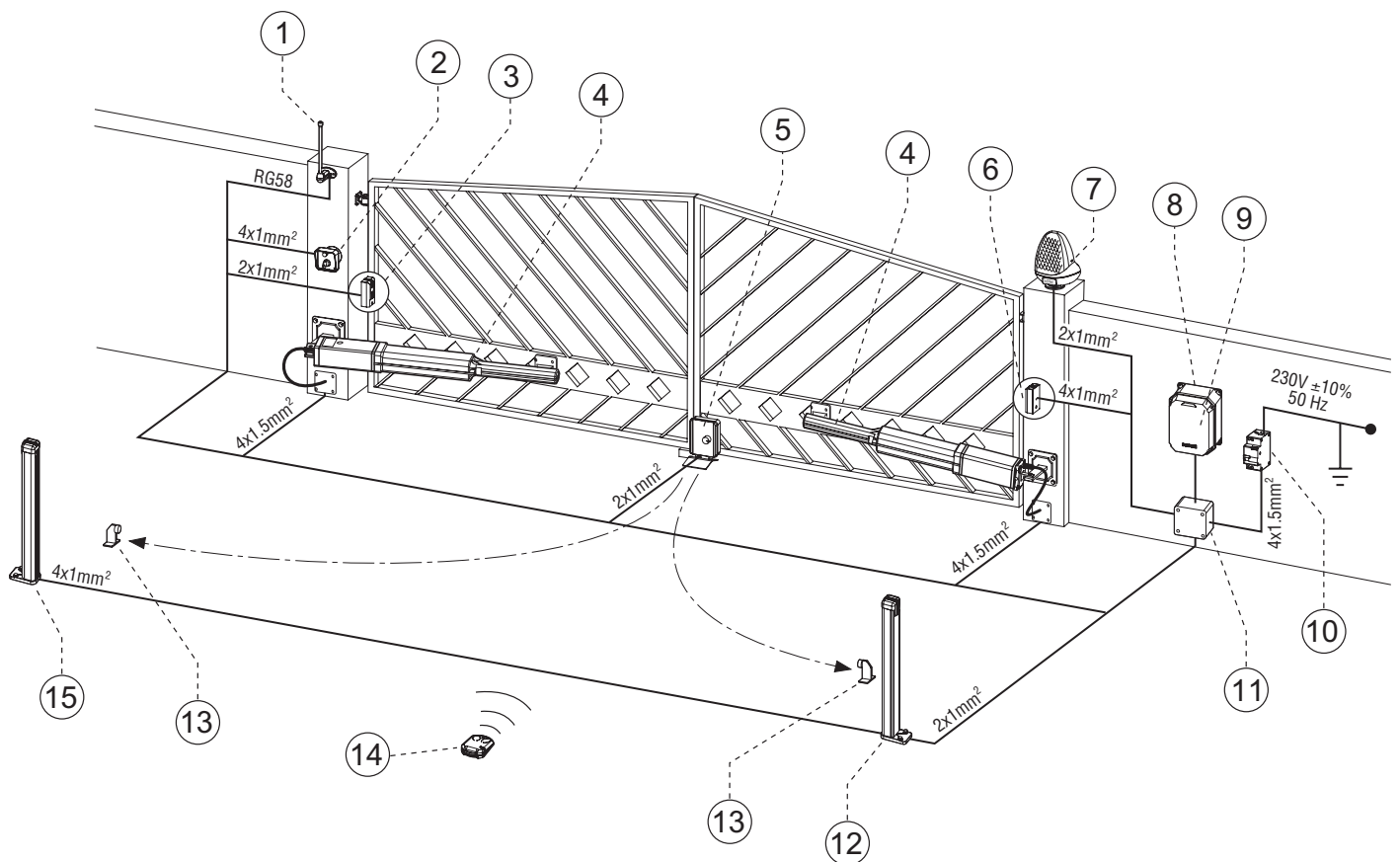

IMPORTANT: all the electrical equipment to be properly earthed

PIC. 14

If the distance from the mains output is more than 50 m, the cable section must be 2.5 mm².

DIAGRAM OF THE ELECTRICAL CONNECTIONS

- | | |
|--|---|
| 1 - Aerial BIRIO A8 | 9 - Plug-in radio receiver ASTRO 43/2 R |
| 2 - Keyswitch PRIT 19 | 10 - 230V - 50Hz differential, magnetic thermal mains switch type 0.03A (beyond 100 m use cables with 2.5 mm Ø) |
| 3 - Photocell transmitter TRIFO 11. Outside | 11 - Junction box |
| 4 - Electro-hydraulic operator HINDI 880 SPRINT | 12 - Post with photocell transmitter TRIFO 11. Inside |
| 5 - Electric lock with stop catcher in closed position | 13 - Gate stop in open position |
| 6 - Photocell receiver TRIFO 11. Outside | 14 - Radio transmitter ASTRO 43/2 TR Small |
| 7 - Flashing lamp MIRI 4 | 15 - Post with photocell receiver TRIFO 11. Inside |
| 8 - Control box ELPRO 13 exp | |

N.W.: CARRY OUT A RISK ANALYSIS IN COMPLIANCE WITH EN 12445 AND EN 12453 NORMS AND FIT ANY SAFETY DEVICE WHERE REQUIRED.

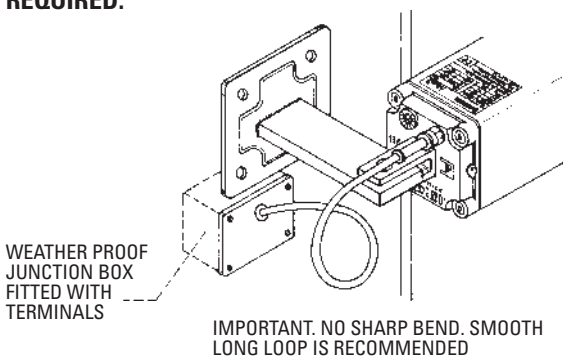

With HINDI 880 SPRINT non locking type, in case of power failure release the electric lock and push open by hand with constant smooth force.

PIC. 15

CONNECTION DIAGRAM FOR SWING GATES *Elpro.13_{exp}*

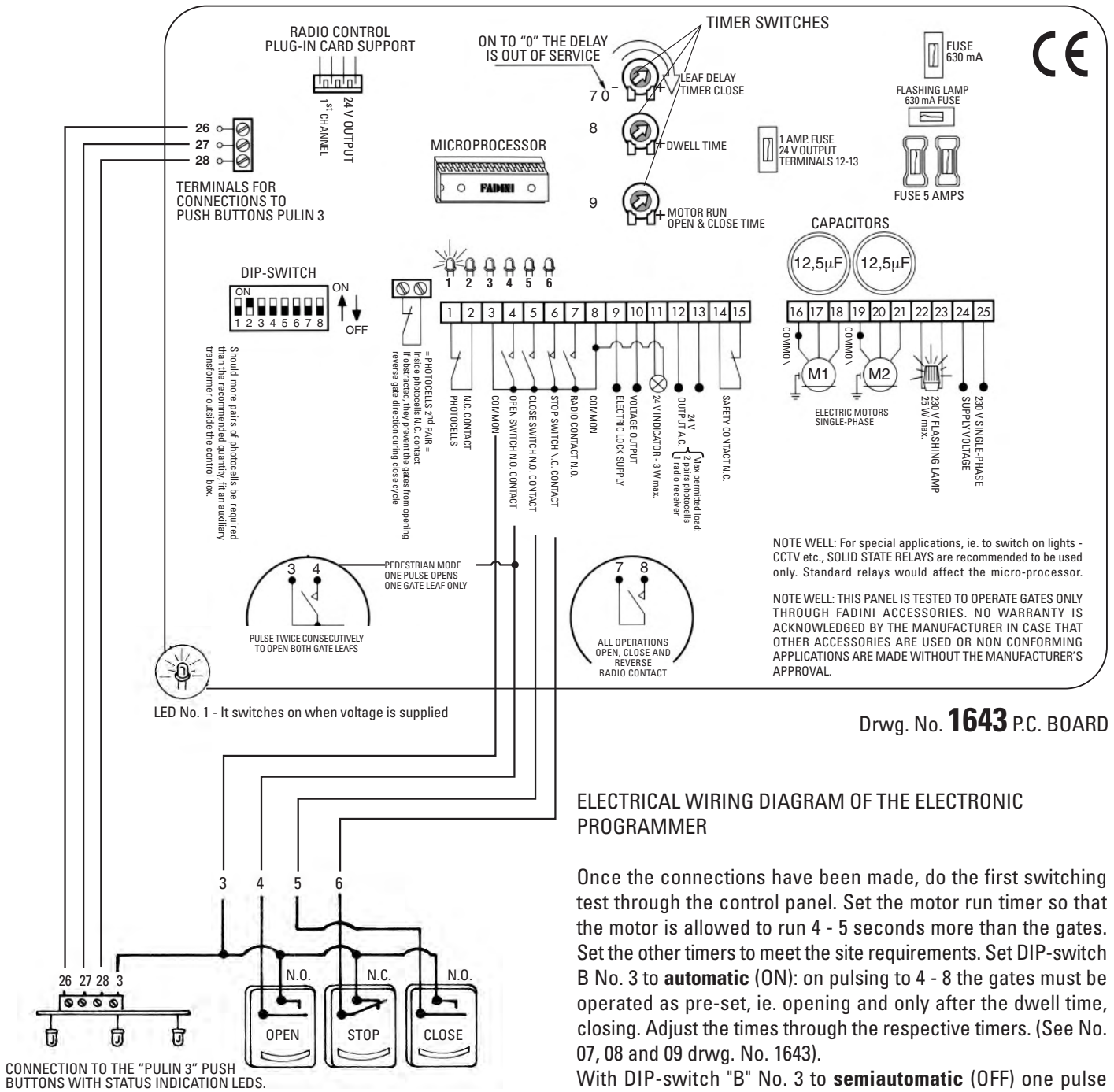

Drwg. No. **1643** P.C. BOARD

ELECTRICAL WIRING DIAGRAM OF THE ELECTRONIC PROGRAMMER

Once the connections have been made, do the first switching test through the control panel. Set the motor run timer so that the motor is allowed to run 4 - 5 seconds more than the gates. Set the other timers to meet the site requirements. Set DIP-switch B No. 3 to **automatic** (ON): on pulsing to 4 - 8 the gates must be operated as pre-set, ie. opening and only after the dwell time, closing. Adjust the times through the respective timers. (See No. 07, 08 and 09 drwg. No. 1643).

With DIP-switch "B" No. 3 to **semiautomatic** (OFF) one pulse opens the gates, a second pulse to 5 - 9 is needed to close the gates. Any one pulse to 7 - 8 will open, close or reverse the gates independently from the operation being performed. It is recommended to carefully read the instructions in the control box to have all the functions performed correctly.

The 6 LEDs on the P.C. board indicate the following:

- Led No. 1 It switches on when voltage is supplied
- Led No. 2 Photocells - Normally on. It switches off when the photocells are obstructed
- Led No. 3 Open - It switches on when the respective switch is activated
- Led No. 4 Close - It switches on when the respective switch is activated
- Led No. 5 Stop - Normally on. It switches off when the respective switch is activated
- Led No. 6 Radio - It switches on whenever a pulse is given, either from remote control, keyswitch or push buttons.

PIC. 16

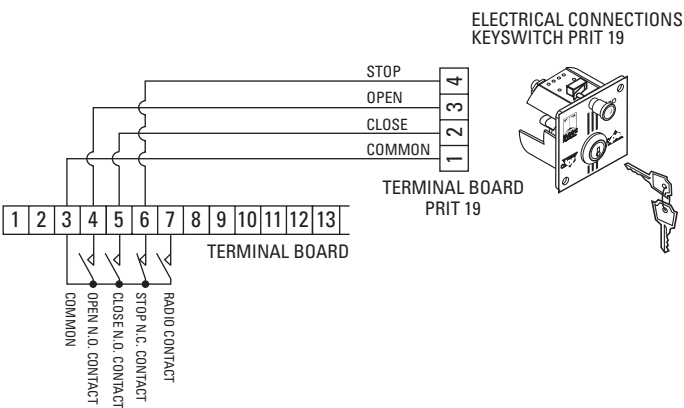

PIC. 17

MAX. PRESSURE
VALVE ADJUSTMENT
"A" Open - Green
"C" Close - Red

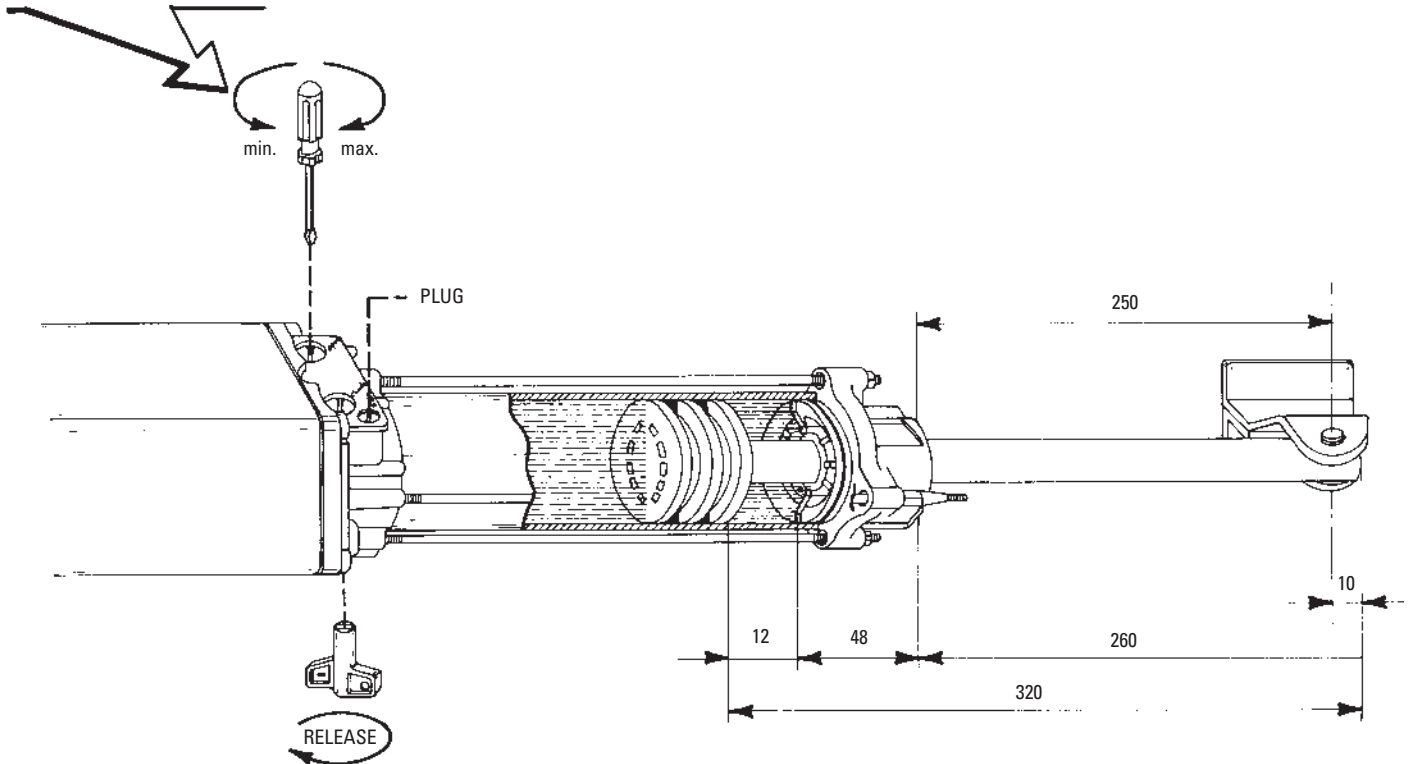

PIC. 18

The 250 mm distance from operator end cap to front fixing centre has the purpose of obtaining a suitable clearance inside the cylinder between the piston and operator cap. This chamber is full of oil and cushions piston end strokes. (Pic. 18).

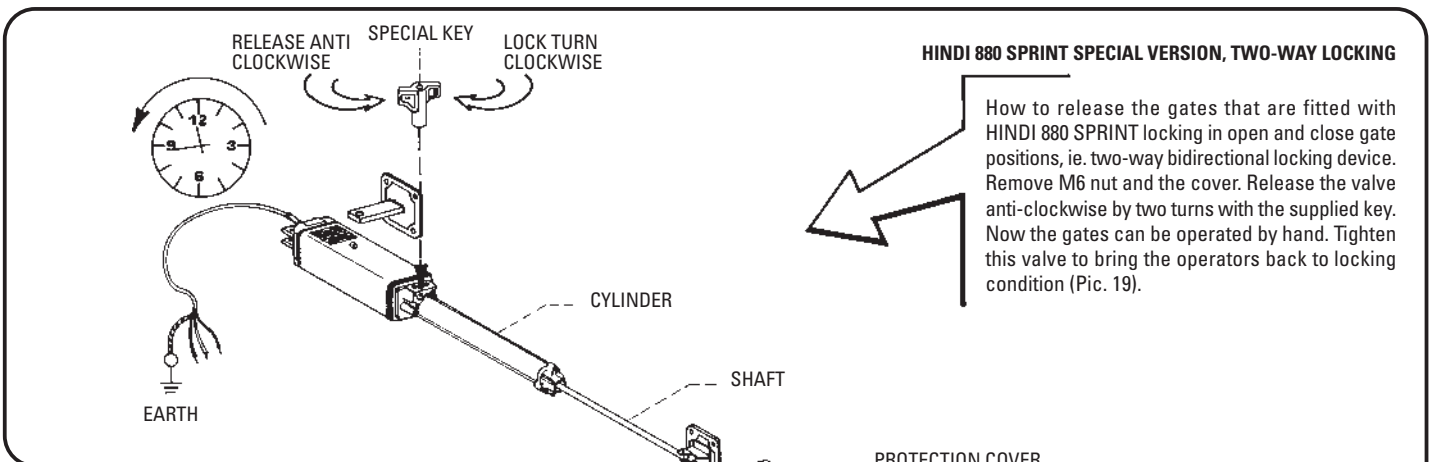

HINDI 880 SPRINT SPECIAL VERSION, TWO-WAY LOCKING

How to release the gates that are fitted with HINDI 880 SPRINT locking in open and close gate positions, ie. two-way bidirectional locking device. Remove M6 nut and the cover. Release the valve anti-clockwise by two turns with the supplied key. Now the gates can be operated by hand. Tightly this valve to bring the operators back to locking condition (Pic. 19).

PIC. 19

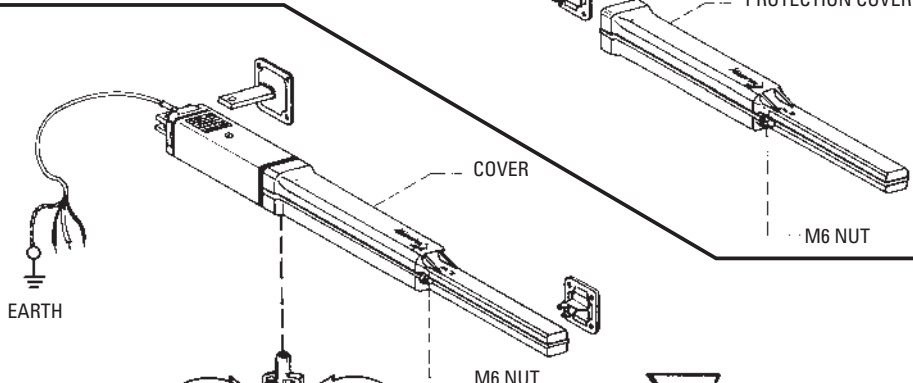

For non locking operator, see page 8 (Pic. 14).

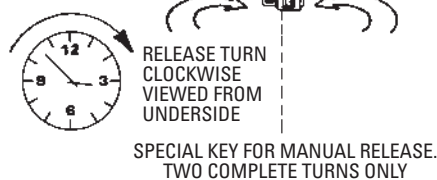

HINDI 880 SPRINT locking in open and close gate positions. No need to remove the cover. See pic. 20. Tighten this valve to bring the operators back to locking condition.

PIC. 20

**NEVER CUT
THE ELECTRIC WIRES**

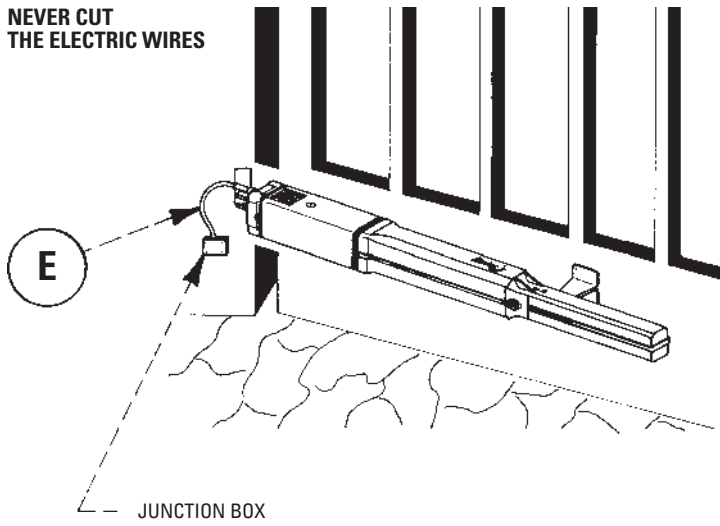

It is essential and most important that the cables "E" are properly removed from their terminal block inside the junction box (Pic.21). Never cut or pull the operator cable away. Also, make sure that the 230 Volt mains switch No. 2 is off. (See page 8, picture 14).

- All the installation is under the complete responsibility of the installation company even if only products by the manufacturing company have been used as illustrated in this manual. It is recommended that all components are installed by strictly keeping to these instructions and drawings, and most of all in compliance with the existing regulations for automatic gates and electrical installations.
- The technical information and application drawings are subject to those changes which may be deemed most necessary.
- All the operators are tested to the maximum power before being packaged (Pic. 22).

PIC. 21

HINDI 880 SPRINT TECHNICAL SPECIFICATIONS

OVERALL DIMENSIONS

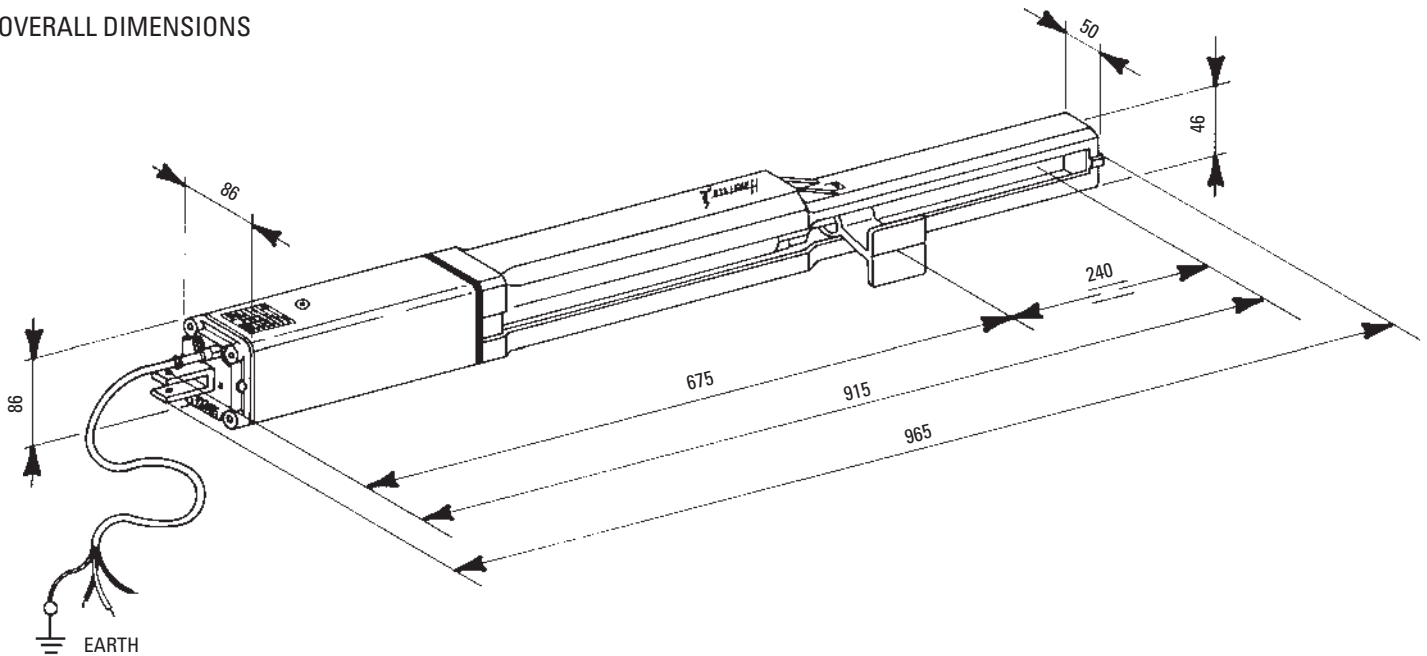

PIC. 22

PISTON AND HYDRAULIC PUMP

Pump flow rate - P5	1.4 l/min.
Average working pressure	1 MPa (10 Bars)
Maximum working pressure	3 MPa (30 Bars)
Working temperature	-25°C +80°C
Time of one out stroke	18 s
Type of hydraulic oil	A 15 FADINI by AGIP
Stroke	240 mm
Piston diameter	45 mm
Piston shaft diameter	16 mm
Max. thrust power OPENING	2'180 N
Max. pushing power CLOSING	2'380 N
Weight complete with accessories	9.5 Kg
Max. gate weight	120 Kg
Dimensions (length x width x height)	965x86x86
Protection standard	IP 553

TWO-PHASE ELECTRIC MOTOR

Power output	0.18 KW (0.25 HP)
Supply voltage / Frequency	230 V - 50 Hz
Absorbed current	1.2 A
Absorbed power	250 W
Capacitor	12.5 µF
Motor rotation speed	1'350 r.p.m.
Intermittent service	S 3

Duty cycle	18 sec. Open - 60 sec. Dwell - 18 sec. Close
Time of one complete cycle	96 s
No. of complete cycles Open - Dwell - Close	37/hour
No. of cycles a year, 8 hours a day	109'000

CLASS H, SINGLE-PHASE ELECTRIC MOTOR, IN AN OIL RESERVOIR. LEFT/RIGHT ROTATION. CONSTANT PUMP FLOW RATE. MOTOR, PUMP AND PISTON ALIGNED ON THE SAME AXIS. CHROME-PLATED PISTON AND PISTON ROD, FINELY POLISHED CYLINDER LINER (Pic. 1 page 2).

Best performance will only be achieved by keeping to these instructions.

HINDI 880 SPRINT

CHECKING AND MAINTENANCE:

To achieve an optimum performance and longer life of the equipment and in observance of the safety regulations, it is recommended that inspections and proper maintenance are made by qualified technicians to the whole installation ie. both the mechanical and electronic parts, as well as wiring.

- Mechanical parts: maintenance every 6 months approx.
- Electronic apparatus and safety equipment: maintenance every month.

IMPORTANT WARNING NOTES

- Before installing the equipment carry out a **Risk Analysis** and fit any required device in compliance with EN 12445 and EN 12453 Safety Norms.
- It is recommended to keep to the instructions here outlined. Check the specifications on the motor sticker with your mains supply.
- Dispose properly of the packaging: cardboard, nylon, polystyrene, through specializing companies.
- Should the operator be removed, **do not cut** the electric cable. This must be properly removed from the terminal board in the junction box.
- Switch off the mains switch before removing the junction box cover where the electric cable of HINDI 880 Sprint is terminated.
- All the system must be earthed by using the yellow/green wire, marked by its specific symbol.
- It is recommended to read the regulations, suggestions and remarks quoted in the booklet "Safety norms".
- Should the operator be removed for maintenance, servicing or repair, tighten the air bleeding screw to prevent oil coming out of the reservoir during transport. (Pic. 10 page 6).

Meccanica Fadini recommends the control panel ELPRO 13 CEI to achieve an installation that is in conformity to the existing safety standards.

The electronic programmer "ELPRO 13" incorporates and can provide all the functions which are required by the most demanding applications with swinging gates. In addition to the standard features of ELPRO 13 (see page 9 pic. 16), the following requirements can be provided: "stroke reversing pulse", pedestrian mode, stop in any gate position by holding down the remote control button.

Among the added features and improvements of "ELPRO 13", in conformity to the European safety standards, there is the mains rotary switch: it is fitted to the box cover and switches off the mains voltage whenever the cover is removed.

The "CE" mark certifies that the operator conforms to the essential requirements of the European Directive art. 10 EEC 73/23, in relation to the manufacturer's declaration for the supplied items, in compliance with the body of the regulations ISO 9000 = UNI EN 29000. Automation in conformity to EN 12453, EN 12445 safety standards.

CE EUROPEAN MARK CERTIFYING CONFORMITY TO THE ESSENTIAL REQUIREMENTS OF THE STANDARDS 98/37/EC

- DECLARATION OF CONFORMITY
- GENERAL WARNINGS
- EN 12453, EN 12445 STANDARDS
- CEI EN 60204-1 STANDARDS
- WARRANTY CERTIFICATE ON THE CUSTOMER'S REQUEST



AUTOMATIC GATE MANUFACTURERS

STICKER FITTED ON TO THE ELECTRIC MOTOR

meccanica FADINI		Hindi 880 SPRINT	
<small>Via Mantova, 177/A - 37053 Cerea (VR) Italy - Tel. 0442 330422 r.a. - Fax 0442 331054</small>			
MOTOR	2 PHASE		
W	250	HP	0.25
VOLTS	230	A	1.2
r.p.m.	1'350	Hz	50
Nm	3'000	µF	12.5
Degree of protection IP 553			
Working pressure max. 3 MPa (30 Bars)			
OIL FADINI A15 BY AGIP			CE
MADE IN ITALY			

N.W.

With all the electro-hydraulic operators, once installed, you need to set the safety pressure valves to meet the gate pushing power/anti-crush requirements. The valve "OPEN" must be set to get higher pressure than "CLOSE". The electric cable is factory-set and must be left free. The encoding remote control, the control box (pre-programmed to meet the most various operation requirements) and a wide range of safety accessories make the system fully automatic.

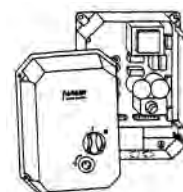

Elpro 13 CEI
SINGLE-PHASE

CUT OFF
MAINS SWITCH

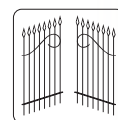

FADINI
the gate opener
Made in Italy

The growth of MECCANICA FADINI has always been based on the development of guaranteed products thanks to our "TOTAL QUALITY CONTROL" system which ensures constant quality standards, updated knowledge of the European Standards and compliance with their requirements, in view of an ever increasing process of improvement.

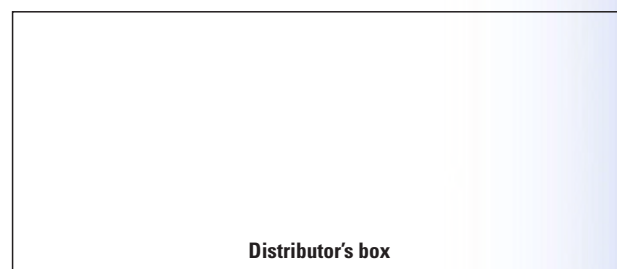

Distributor's box

The manufacturers reserve the right to change the products without any previous notice