

Elpro•37

I

Programmatore elettronico monofase - trifase con freno elettronico per cancelli scorrevoli e automazioni con o senza finecorsa (max 1,5 CV trifase o 1,0 CV monofase).

GB

Single-Three phase electronic control board for sliding gate and automatic systems with or without limit switches (max 1,5 HP three-phase or 1,0 CV single-phase).

F

Programmeur électronique monophasé - triphasé avec frein électronique pour portails coulissant et automatismes avec ou sans fin de course (max 1,5 HP triphasé ou 1,0 HP monophasé).

D

Elektronische Steuerung, einphasig – dreiphasig, mit Elektrobremse für Schiebetore, und Automationen mit oder ohne Endschalter max 1,5 PS dreiphasig oder 1,0 PS einphasig)

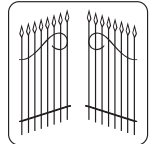

FADINI
l'apricancello
Made in Italy

I

- FRENO ELETTRONICO
- FUNZIONE PASSO PASSO
- UOMO PRESENTE
- APERTURA PEDONALE
- POSSIBILITA' DI ESCLUDERE LAMPEGGIANTE IN PAUSA

- FUNZIONE OROLOGIO
- AUTOMATICO / SEMIAUTOMATICO
- USCITA ELETTROSERRATURA
- LUCE DI CORTESIA TEMPORIZZATA

GB

- ELECTRONIC BRAKE- FUNZIONE PASSO PASSO
- STEP BY STEP FUNCTION
- HOLD-ON SWITCHED (DEADMAN) CONTROL
- PEDESTRIAN OPENING
- FLASHING LAMP DURING DWELL TIME. MADE SWITCHED ABLE

- TIME CLOCK OPTION
- AUTOMATIC / SEMI-AUTOMATIC FUNCTION
- ADJUSTABLE COURTESY LIGHT TIME
- ELECTRIC LOCK OUTPUT

F

- FREIN ELECTRONIQUE
- FONCTION PAS A PAS
- HOMME MORT
- OUVERTURE PIETON
- POSSIBILITE D'ETEINDRE LA LAMPE DE SIGNALISATION EN PAUSE

- FONCTION HORLOGE
- FONCTION AUTOMATIQUE / SEMIATUMATIQUE
- LAMPE D'ECLAIRAGE TEMPORISEE
- SORTIE SERRURE ELECTRIQUE

D

- ELEKTROBREMSE
- SCHRITTWEISE FUNKTION
- TOTMANNBETRIEB
- FUßGÄNGERFUNKTION
- MÖGLICHKEIT ZUM AUSSCHLUSS DER BLINKLEUCHTE BEI DER PAUSE

- UHR-FUNKTION
- AUTOMATISCH/HALBAUTOMATISCH
- ELEKTROSCHLOß AUSGANG
- HILFSBELEUCHTUNG TIMER

Dis. N. 7583



meccanica
FADINI

Via Mantova 177/A - 37053 Cerea (VR) Italy
Tel. +39 0442 330422 r.a. - Fax. +39 0442 331054
e-mail: info@fadini.net - www.fadini.net



ATTENZIONE: prima di procedere ai collegamenti elettrici accertarsi che il selettore della tensione elettrica 230V o 400V sia impostato correttamente.
In caso si utilizzi un motore con freno meccanico o si sostituisca un ELPRO 10 il Dip-Switch N°12 deve essere lasciato in OFF.

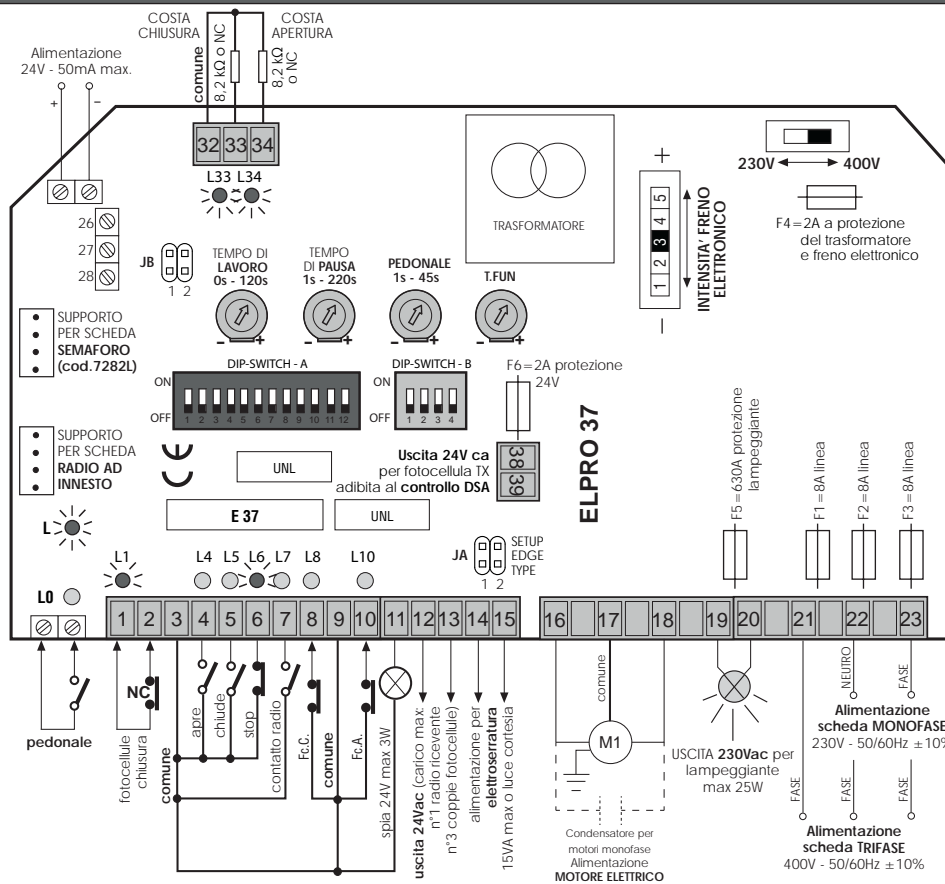

NOTA BENE:
I led verdi devono essere sempre accesi.

Descrizione generale: Il programmatore elettronico ELPRO 37 è stato realizzato come soluzione per la gestione di un'automazione scorrevole con o senza freno elettronico e finecorsa. Alimentato a 230V 50/60Hz monofase o 400V 50/60Hz trifase, l'ELPRO 37 risponde alle normative di sicurezza di Bassa Tensione 2006/95 CE e Compatibilità Elettromagnetica 2004/108/CE e pertanto si consiglia l'installazione da parte di personale tecnico qualificato secondo le normative di sicurezza vigenti. La Ditta costruttrice non si assume responsabilità circa l'uso improprio del programmatore; inoltre si riserva il diritto di apportare in qualunque momento modifiche e aggiornamenti al programmatore.

IMPORTANTE PER L'INSTALLAZIONE E IL CORRETTO FUNZIONAMENTO:

- Il Programmatore deve essere installato in un luogo asciutto e protetto, sono previsti a proposito i fori di fissaggio sul contenitore universale FADINI e su cassetta commerciale
 - Accertarsi che l'alimentazione al programmatore elettronico sia 230V ± 10% oppure 400V ± 10%
 - Accertarsi che l'alimentazione al Motore Elettrico sia 230V ± 10% oppure 400V ± 10%
 - Per distanze superiori ai 50 metri aumentare la sezione dei fili.
 - Applicare un interruttore Magneto-Termico Differenziale del tipo 0,03A ad alta sensibilità all'alimentazione del programmatore
 - Per Alimentazione, Motore Elettrico e Lampeggiante usare fili di sezione da 1,5mm² fino a 50m di distanza
 - Finecorsa, Fotocellule, Pulsantiere e accessori usare cavi con fili da 1mm²
 - Se non si usano le Fotocellule eseguire un ponte tra i morsetti 1 e 2
 - Se non si usa nessun Pulsante di stop eseguire un ponte tra i morsetti 3 e 6
 - Trimmer del Tempo di Lavoro Apre/Chiude deve essere sempre superiore al tempo effettivo della corsa del cancello
- N.B.: Per applicazioni quali accensioni luci, Telecamere, ecc. utilizzare Relè Statici per non creare disturbi al microprocessore

Led di Diagnostica:

- L Acceso** = Presenza Tensione di rete 230V o 400V e integrità fusibili F1, F2, F3, F4, F5, F6
- L0 Acceso** = Pedonale, si illumina ad ogni comando pedonale
- L1 Acceso** = Coppia di Fotocellule Chiusura, nessun ostacolo presente
- L4 Spento** = Apre, si illumina ad impulso di comando apre
- L5 Spento** = Chiude, si illumina ad impulso del comando di chiusura
- L6 Acceso** = Blocco, si spegne ad impulso del comando di stop
- L7 Spento** = Radio, si illumina ad ogni impulso del trasmettitore e contatto radio
- L8 Acceso** = Si spegne a Fc.C. impegnato M1
- L10 Acceso** = Si spegne a Fc.A. impegnato M1
- L33 Acceso** = Costa a protezione chiusura, nessun ostacolo presente
- L34 Acceso** = Costa o fotocellula a protezione apertura, nessun ostacolo presente

NEL CASO DI MANCATO FUNZIONAMENTO

- Accertarsi che l'alimentazione al programmatore elettronico sia 230V ± 10% o 400V ± 10%
- Accertarsi che l'alimentazione al Motore Elettrico sia 230V ± 10% o 400V ± 10%
- Controllare tutti i fusibili
- Controllare che le Fotocellule siano in contatto chiuso
- Controllare che non ci sia una caduta di tensione tra il Programmatore Elpro e Motore Elettrico
- Controllare tutti i contatti NC del programmatore
- Controllare il corretto collegamento e funzionamento dei finecorsa

Simbologia

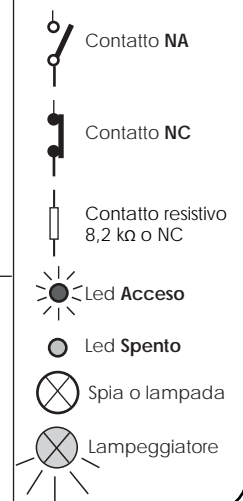

ATTENZIONE: prima di procedere ai collegamenti elettrici accertarsi che il selettore della tensione elettrica 230V o 380V sia impostato correttamente.
In caso si utilizzi un motore con freno meccanico o si sostituisca un ELPRO 10 il Dip-Switch N°12 deve essere lasciato in OFF.

Dip-Switch A

- 1 = ON Fotocellula ferma in apertura
- 2 = ON Radio non inverte in apertura
- 3 = ON Chiude in automatico
- 4 = ON Prelampeggio Attivo
- 5 = ON Radio passo-passo
- 6 = ON Uomo presente
- 7 = ON Lampeggiatore spento durante la pausa in Automatico
- 8 = ON Richiude in Apertura e in pausa dopo passaggio su Fotocellule
- 9 = ON Controllo DSA fotocellule prima di ogni manovra
- 10 = ON Fotocellule libere da ostacoli prima di muovere
- 11 = libero
- 12 = ON Frenatura elettronica attiva

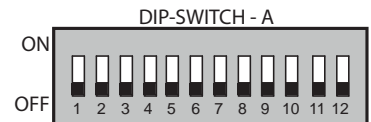

Dip-Switch B

- 1 = ON imposta durata frenatura
- 2 = ON imposta tempo di arresto addizionale alla frenatura su intervento delle sicurezze
- 3 = ON imposta durata serratura o luce di cortesia
- 4 = OFF libero



Accessorio	Collegamenti elettrici	Dip-Switch e segnalazione LED delle varie funzioni
Fotocellule Apertura: 	<p>tutti i contatti NC degli accessori di sicurezza quali Fotocellule (ricevitori) devono essere collegati in serie ai morsetti 1 e 2</p> <p>uscita 24Vac carico max: n°1 radio ricevente n°3 coppie fotocellule</p>	DIP-SWITCH-A N° 1: <ul style="list-style-type: none"> ON: ferma in apertura e inverte in chiusura a ostacolo rimosso 1 OFF: non ferma in apertura e inverte in chiusura in presenza di ostacolo <ul style="list-style-type: none"> L1 Acceso= nessun ostacolo presente, si spegne ad ostacolo presente
Selettore a chiave: 	<p>contatti NA e NC da collegare ai rispettivi morsetti dei selettori o pulsantiere. Tutte le possibili configurazioni sono allegate ai rispettivi accessori di comando</p>	<ul style="list-style-type: none"> L4 Spento= nessun contatto APRE, si accende ad ogni impulso di apertura L5 Spento= nessun contatto CHIUDE, si accende ad ogni impulso di chiusura L6 Acceso= contatto di STOP chiuso, si spegne ad ogni impulso di stop
Contatto Radio (con funzione passo-passo): 	<p>collegando un qualsiasi contatto NA tra i due morsetti si può ottenere ad ogni impulso:</p> <ul style="list-style-type: none"> - Solo apertura: Dip 2=ON e Dip 5=OFF - Inversione di marcia ad ogni impulso Dip 2=OFF e Dip 5=OFF - Passo Passo: Apre-Stop-Chiude-Stop Dip 2=OFF e Dip 5=ON - In fase di apertura non accetta nessun comando. In pausa e in chiusura ad ogni comando esegue lo stop con inversione di marcia: Dip 2=ON e Dip 5=ON 	DIP-SWITCH-A N°2 e N°5: <ul style="list-style-type: none"> ON: In apertura non inverte e non blocca 2 OFF: In apertura blocca e inverte sempre ON: Passo passo con blocco intermedio 5 OFF: Inverte il movimento ad ogni impulso radio L7 Spento= nessun contatto RADIO, si accende ad ogni impulso del contatto radio
Uscita Spia di Segnalazione da 24V - max 3W:	<p>Uscita per una eventuale lampada di segnalazione 24V max 3W dello stato dell'automazione: Spia Accesa = Cannello Aperto Spia Spenta = Cannello Chiuso Lampeggia 0,5s (veloce)= movimento di chiusura Lampeggia 1s (normale)= movimento di apertura</p>	
Fincorsa: 	<p>IMPORTANTE: se i fincorsa non sono utilizzati, ponticellare gli ingressi 8 - 9 - 10. Utilizzare Fc. normalmente chiusi</p>	<ul style="list-style-type: none"> L8 Acceso= si spegne a Fc Chiusura L10 Acceso= si spegne a Fc Apertura

COSTE DI SICUREZZA

I due ingressi previsti per la gestione dei bordi sensibili, sono separati per la fase di apertura e la fase di chiusura. Inoltre è possibile scegliere il tipo di contatto a loro collegato, tra quello meccanico NC e quello resistivo 8,2 kΩ tramite i due ponticelli JA1 e JA2 (SELECT EDGE TYPE). Grazie alla presenza di un circuito a microcontrollore dedicato e separato a bordo della scheda, viene continuamente monitorata l'effettiva integrità e perfetta funzionalità del sistema di sicurezza. Ogni eventuale guasto o perdita di efficienza verrà segnalato tramite il lampeggio dei led L33 e L34.

Selezione tipo di funzionamento:

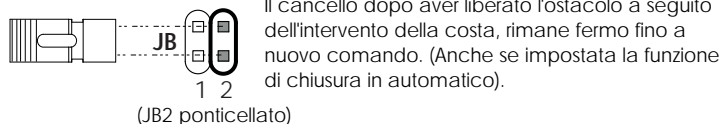
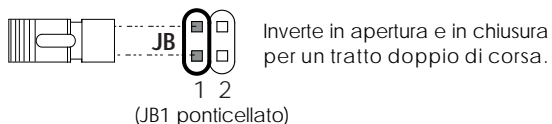
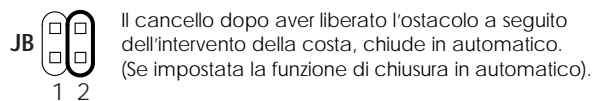
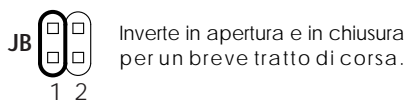

Accessorio

Collegamenti elettrici

Segnalazione LED

Costa di sicurezza in Chiusura:

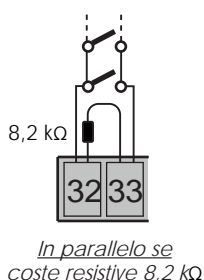
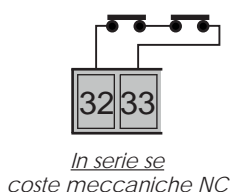

Normalmente Acceso:
L33 quando interviene la costa il led si spegne.

Selezione tipo di costa utilizzata:

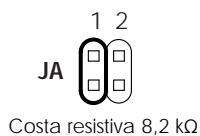
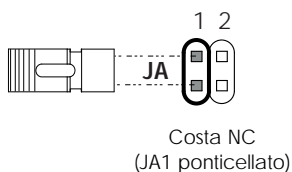

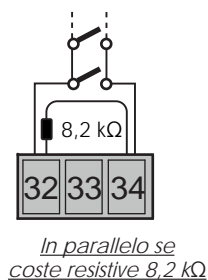
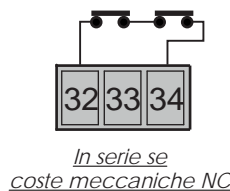
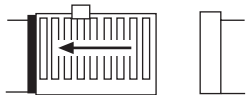

Costa di sicurezza e fotocellule in Apertura:

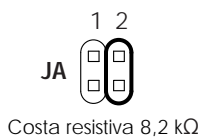
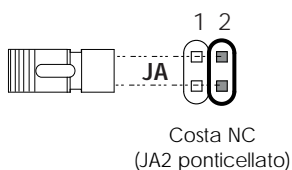

Normalmente Acceso:
L34 quando interviene la costa il led si spegne.

Selezione tipo di costa utilizzata:

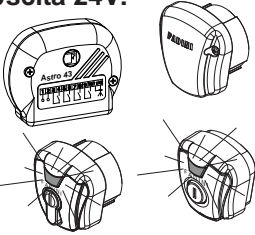
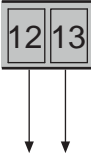
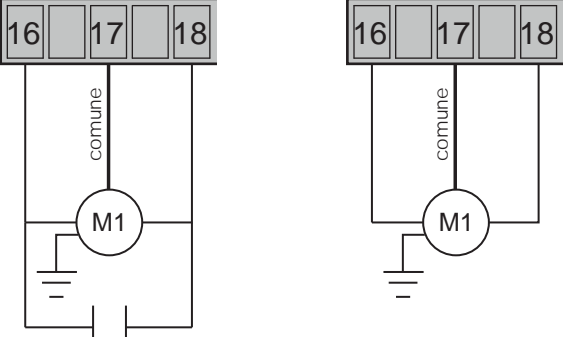

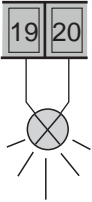
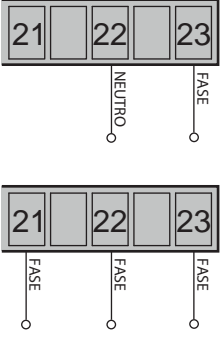
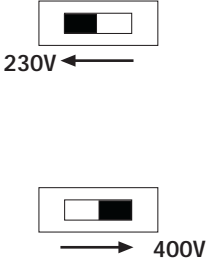
Accessorio	Collegamenti elettrici	Dip-Switch e segnalazione LED delle varie funzioni
<p>Uscita 24V:</p> 	 <p>USCITA 24Vac per carico max: n°3 coppie di fotocellule n°1 Radio ricevente n°1 Led selettore Chis 37 / Chis-E 37 Tutte le istruzioni sono allegate ai rispettivi accessori di comando</p>	
<p>Uscita per motori:</p> <p>monofase 230V max 735W - 1,0 HP</p> <p>o</p> <p>trifase 400V max 1100W - 1,5 HP</p>	 <p>CONDENSATORE Alimentazione MOTORI ELETTRICI MONOFASE</p> <p>Alimentazione MOTORI ELETTRICI TRIFASE</p>	 <p>TEMPO DI LAVORO APRE-CHIUDE 0s - 120s</p> <p>TEMPO DI PAUSA 1s - 220s</p>
<p>Lampeggiante 230V:</p> 	 <p>USCITA 230Vac per lampeggiante max 25W</p>	<p>DIP-SWITCH-A N°4 e N°7</p> <p><input checked="" type="checkbox"/> ON: Prelampeggio prima del movimento 4 OFF: Senza prelampeggio</p> <p><input checked="" type="checkbox"/> ON: Lampeggiante disattivato durante la pausa in Funzionamento Automatico (con Dip 3= ON) 7 OFF: Lampeggia durante la pausa in Funzionamento Automatico (con Dip 3= ON)</p>
<p>Alimentazione scheda 230V - 400V MONOFASE</p> <p>o</p> <p>TRIFASE</p>	 <p>Alimentazione scheda MONOFASE 230V - 50/60Hz ± 10%</p> <p>Alimentazione scheda TRIFASE 400V - 50/60Hz ± 10%</p>	 <p>230V ←</p> <p>→ 400V</p>

Accessorio

Collegamenti elettrici

Dip-Switch e segnalazione LED delle varie funzioni

Collegamento led Pulin 3:

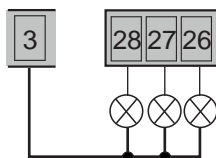
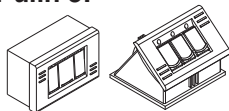

morsettiera per il collegamento dei led della pulsantiera Pulin 3

Uscita 24Vcc-5W:



Schedina Semaforo ad Innesto (Optional - cod.7282L):

L'alimentazione della schedina è indipendente da quella della scheda del programmatore: 230V 50Hz con uscita di 100W a 230V per lampada.

Logica di Funzionamento:

- Luce VERDE= passaggio APERTO
- Luce ROSSA= passaggio CHIUSO
- Luce GIALLA= interviene prima del passaggio da luce Verde a luce Rossa.

Nota: In funzionamento Pedonale il Semaforo rimane sempre ROSSO.

Dip-Switch A

- 4= ON Prelampeggio Attivo: luce semaforo Rosso - Giallo - Verde
- 4= OFF Prelampeggio Disattivo: luce semaforo Rosso - Verde

Funzionamento con 2 lampade (Rossa e Verde):

Dip-Switch A 4 = OFF

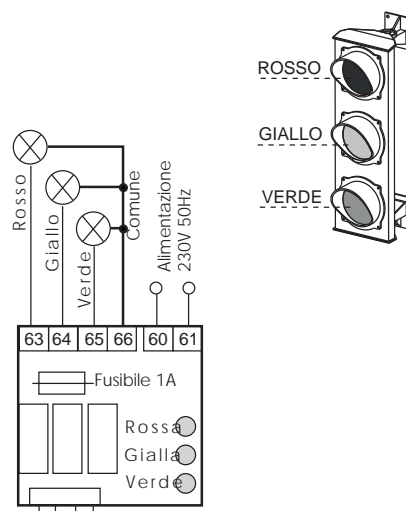

(Optional: Schedina Semaforo ad Innesto per lampade a 230V) codice **7282L**

FUNZIONI PER L'APERTURA SCORREVOLE

Descrizione

Dip - Switch e segnalazione LED delle varie funzioni

AUTOMATICO / SEMIAUTOMATICO:

Ciclo Automatico: ad un impulso di comando apre, il cancello si apre, si ferma in Pausa per il tempo impostato sul **Trimmer Pausa**, scaduto il quale richiude automaticamente.

Ciclo Semiautomatico: ad un impulso di comando apre, il cancello si apre e si blocca in posizione aperto. Per Chiudere il passaggio bisogna dare l'impulso di chiusura.

DIP-SWITCH-A N°3:

- ON: Chiude in Automatico
- 3 OFF: Semiautomatico



Trimmer Pausa: si regola il tempo di pausa nella modalità Automatico da 1s fino 220s

APERTURA PEDONALE:

Si ottiene l'apertura pedonale da cancello completamente chiuso tramite il comando sui contatti pedonale P-P.

(Si consiglia l'uso dell'apertura pedonale con Dip-A N°3= ON per la richiusura automatica).

La funzione "Apertura pedonale" non è attiva durante il primo ciclo di funzionamento successivo ad una mancanza di tensione di alimentazione.

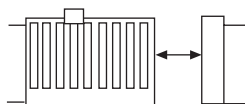

APERTURA PEDONALE
1s - 45s

- L0 Spento= nessun contatto pedonale si accende ad ogni comando pedonale

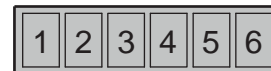
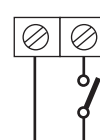

APRE PEDONALE

RICHIUSURA AL PASSAGGIO SULLE FOTOCELLULE: in fase di apertura e in pausa (con DIP-A N°3=ON)

Funzione che permette la richiusura automatica del cancello dopo 3s dal passaggio attraverso il fascio delle fotocellule.

DIP-SWITCH-A N°8:

- ON: Richiusura automatica al passaggio sulla coppia fotocellule dopo 3 secondi
- 8 OFF: Nessuna richiusura automatica al passaggio su fotocellule

DSA: CONTROLLO AUTOMATICO DELLE FOTOCELLULE

Per il controllo **DSA** (Dispositivo Sicurezza Autotest) collegare a questa uscita **le sole fotocellule trasmettitori** e selezionare il **Dip-A N°9=ON**. Prima di ogni movimento del cancello, se questa funzione è abilitata, l'Elpro 37 controlla che tutti i dispositivi fotocellule collegati siano liberi da ostacoli e correttamente funzionanti, in caso contrario il cancello non parte.



Uscita 24V ca per fotocellula TX adibita al controllo DSA

DIP-SWITCH-B N°9:

- ON: Attiva il controllo delle sicurezze DSA
- 9 OFF: Disattiva controllo delle sicurezze DSA

UOMO PRESENTE:

Si ottiene il comando di apertura e chiusura "ad azione mantenuta" (senza autoritenuta nei Relè). E' richiesta la presenza dell'operatore durante tutto il movimento dell'automazione fino al rilascio del pulsante o della chiave del selettore.

DIP-SWITCH-B N°6:

- ON: Attiva funzione Uomo Presente
- 6 OFF: Disattiva Uomo Presente

PARTY FUNCTION

APERTURA MEDIANTE OROLOGIO ESTERNO:

Collegare il contatto NA dell'Orologio ai morsetti n°4 APRE e n°3 COMUNE, attivando la richiusura automatica con il Dip-Switch n°3=ON.

Funzionamento: programmare l'orario di apertura sull'orologio, all'ora impostata il cancello si apre rimanendo aperto (il lampeggiante si spegne), e non accetterà più nessun comando (anche radio) sino allo scadere del tempo impostato sull'orologio, allo scadere del quale, dopo il tempo di pausa, seguirà la chiusura automatica.

Durante la sosta a cancello aperto con comando "orologio" la spia di segnalazione emette due lampeggi ravvicinati seguiti da una lunga pausa.

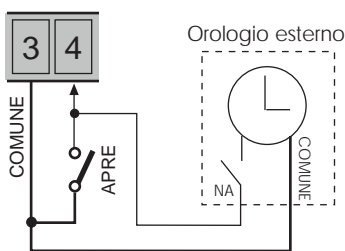

DIP-SWITCH-A N°3:

- ON: Chiude in Automatico
- 3 OFF: Semiautomatico

IMPORTANTE: utilizzare sempre e solo con Dip-A N°3= ON

FUNZIONI FRENO ELETTRONICO

ATTENZIONE:
In caso si utilizzi un motore con freno meccanico o si sostituisca un *ELPRO 10* il Dip-Switch N°12 deve essere lasciato in OFF

Descrizione	Dip - Switch e trimmer delle varie funzioni
<p>Per attivare il freno elettronico è sufficiente porre in ON il Dip-Switch - A n. 12 e regolare l'intensità del freno elettronico tramite il selettore in figura.</p> <p><u>Le regolazioni preimpostate in fabbrica sono idonee per la maggior parte delle installazioni.</u></p> <p>Per una regolazione più fine del freno elettronico è possibile impostare i vari parametri di frenatura come illustrato nelle <i>impostazioni avanzate del freno elettronico</i>.</p>	

IMPOSTAZIONI AVANZATE DEL FRENO ELETTRONICO

ATTENZIONE: deve essere attivato il freno elettronico tramite il dip-switch n. 12

Funzione	Descrizione	Dip - Switch e trimmer delle varie funzioni						
Durata Frenatura:	<p>Per regolare la durata di intervento del freno elettronico porre in ON il Dip-Switch B N°1 e regolare il tempo di frenatura tramite il trimmer T.FUN.</p> <p><u>Una volta conclusa la taratura della Durata della Frenatura mettere in OFF tutti i Dip-Switch B.</u></p>	<p><i>Operazioni</i></p> <table border="1"> <thead> <tr> <th>I</th> <th>II</th> <th>III</th> </tr> </thead> <tbody> <tr> <td></td> <td>T.FUN 0s - 2s</td> <td></td> </tr> </tbody> </table>	I	II	III		T.FUN 0s - 2s	
I	II	III						
	T.FUN 0s - 2s							
Tempo di arresto addizionale alla frenatura sulle sicurezze:	<p>Per impostare il tempo di arresto addizionale alla frenatura porre in ON il dip-switch B n. 2 e regolare la durata di arresto tramite il trimmer T.FUN.</p> <p><u>Una volta conclusa la taratura del Tempo di arresto addizionale alla frenatura mettere in OFF tutti i Dip-Switch B.</u></p> <p><u>N.B.: questa funzione è attiva e regolabile anche con freno elettronico disattivo. Permette di aumentare il tempo di inversione su intervento fotocellule o coste di sicurezza in modo da ottenere inversioni sicure con cambio di direzione del moto del cancello specie nei motori monofase con grande inerzia.</u></p>	<p><i>Operazioni</i></p> <table border="1"> <thead> <tr> <th>I</th> <th>II</th> <th>III</th> </tr> </thead> <tbody> <tr> <td></td> <td>T.FUN 0s - 3s</td> <td></td> </tr> </tbody> </table>	I	II	III		T.FUN 0s - 3s	
I	II	III						
	T.FUN 0s - 3s							
<p>Elettroserratura:</p> <p>o Luce di Cortesia:</p>	<p>Per impostare il tempo di funzionamento dell'elettroserratura o della luce di cortesia collegata all'uscita 14-15 porre in ON il dip-switch B n. 3 e regolare la durata di funzionamento tramite il trimmer T.FUN.</p> <p><i>Il trimmer T.FUN. in questa modalità permette di regolare il tempo di attivazione di una elettroserratura da 0s a 5s nella prima metà della corsa del trimmer. Nella seconda metà della corsa consente di collegare all'uscita 14-15 un relè per il comando di una luce di cortesia regolabile da 30s a 5min.</i></p> <p><u>Una volta impostato il tempo di funzionamento dell'elettroserratura o della luce di cortesia mettere in OFF tutti i Dip-Switch B.</u></p> <div style="display: flex; align-items: center;"> <div style="border: 1px solid black; padding: 2px; margin-right: 10px;">14 15</div> <div> <p>Uscita alimentazione 12Vac per elettroserratura 15VA max o relè per comando luce di cortesia</p> </div> </div>	<p><i>Operazioni</i></p> <table border="1"> <thead> <tr> <th>I</th> <th>II</th> <th>III</th> </tr> </thead> <tbody> <tr> <td></td> <td>T.FUN 5s 30s 0s 5min</td> <td></td> </tr> </tbody> </table>	I	II	III		T.FUN 5s 30s 0s 5min	
I	II	III						
	T.FUN 5s 30s 0s 5min							

ATTENTION: Before starting the electrical connections, check the voltage (230V or 400V) selector switch to be set correctly.
 In cases a motor with mechanical brake is used or a control board ELPRO 10 is to be changed, the DIP-switch No.12 has to be in OFF.

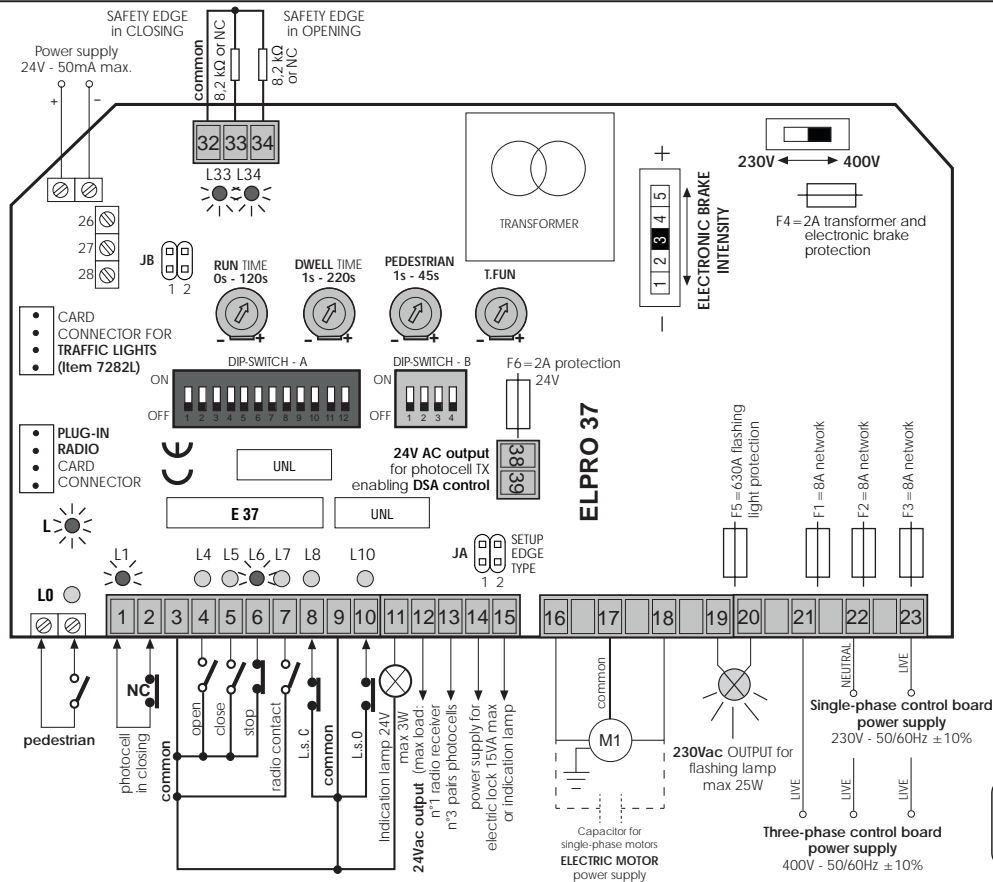

NOTE:
 The green LEDs must always be on.

General description: the electronic control box ELPRO 37 has been developed to provide a reliable unit to control sliding gate automatic systems with or without electronic brake and limit switches. Single-phase 230V 50/60Hz or Three-phase 400V 50/60Hz ELPRO 37 complies with the Low Voltage Norms 2006/95 CE and Electro-magnetic Compatibility 2004/108/CE. Installation is recommended by qualified technical installation agents in compliance with the existing regulations. The manufacturer is not liable for any incorrect use of this appliance; and also reserves the right to change and update it without previous notice.

IMPORTANT FOR THE INSTALLATION AND THE CORRECT FUNCTIONING:

- The control box must be installed in a dry and sheltered place; suitable holes are provided with the FADINI universal box for fitting purpose and in case any commercial box is used, this must be adequate to the job.
 - Make sure that power supply to the control board be 230V ± 10% or 400V ± 10%.
 - Make sure that power supply to the electric motor be 230V ± 10% or 400V ± 10%
 - For distances longer than 50 metres increase the section of the wires.
 - Fit the mains to the control box with a high sensitivity, 0.03A, differential, magnetic-thermal circuit breaker.
 - Cables with 1.5mm² section wires are to be used for the power supply, electric motor and flasher for distances up to 50 m.
 - Cables with 1mm² section wires are to be used for the limit switches, photocells, push buttons and accessories.
 - If no photocells are used link out terminals 1 and 2.
 - If no stop button is used link out terminals 3 and 6.
 - Open/Close motor run time trimmer must be always superior to the time actually required for the gate travel.
- N.W.: For applications such as light switching, CCTV, etc. use solid state relays to prevent the microprocessor from being affected.

Diagnostic LEDs:

- L ON** = Board on 230V or 400 V voltage and F1, F2, F3, F4, F5, F6 fuses all right
- L0 ON** = Pedestrian mode, it switches on by any pedestrian pulsing
- L1 ON** = Pair photocells in Closing not obstructed
- L4 OFF** = Open, it switches on by any open pulse
- L5 OFF** = Close, it switches on by any close pulse
- L6 ON** = Stop, it switches off by any stop pulse
- L7 OFF** = Radio, it switches on by any pulse from the transmitter/radio contact
- L8 ON** = It switches off when Fc.C (limit switch Closing = L-sw.C) is engaged, M1
- L10 ON** = It switches off when Fc.O. (limit switch Opening = L-sw.O) is engaged, M1
- L33 ON** = Safety edge protecting closing not obstructed
- L34 ON** = Safety edge protecting opening not obstructed

IN CASE OF FAILURE PLEASE MAKE SURE THAT:

- Power supply to the electronic control board is 230V ± 10% or 400V ± 10%
- Power supply to the electric motor is 230V ± 10% or 400V ± 10%
- All of the fuses is all right
- The photocell contacts are closed
- No voltage drop has occurred from the Elpro board to the electric motor
- The limit switches are properly connected and work correctly
- All of the NC contacts of the control board are all right.

Symbols

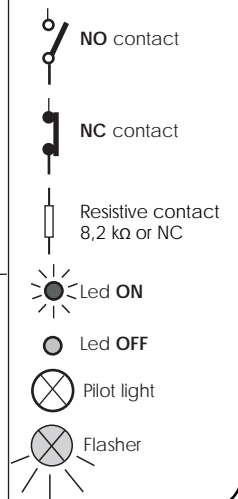

! ATTENTION: Before starting the electrical connections, check the voltage (230V or 400V) selector switch to be set correctly.
In cases a motor with mechanical brake is used or a control board ELPRO 10 is replaced, the DIP-switch No.12 has to be in OFF.

Dip-Switch A

- 1 = ON Photocells stop gate in opening
- 2 = ON Radio, no reversing in opening
- 3 = ON Automatic closing
- 4 = ON Pre-flashing enabled
- 5 = ON Radio step-by-step
- 6 = ON Dead man
- 7 = ON Flasher off in Dwell time in Automatic
- 8 = ON Gate re-closing in Opening and Dwell on Photocells engaging
- 9 = ON DSA control of photocells before any movement
- 10 = ON Photocells not obstructed before moving
- 11 = Blank
- 12 = ON Electronic brake enabled

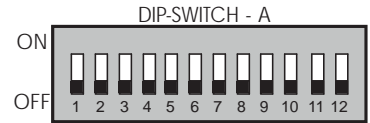

Dip-Switch B

- 1 = ON set braking duration
- 2 = ON set additional stop time after braking when safety devices are activated
- 3 = ON set electric lock or courtesy lamp duration
- 4 = OFF Blank







Accessory	Electrical connections	Dip-Switch setting and LED indication of functions
<p>Photocells in Opening:</p>	<p>All NC contacts of safety accessories such as Photocells (receivers) must be connected in series with terminals 1 and 2</p> <p>24Vac output max. load: n°1 radio receiver n°3 pairs photocells</p>	<p>DIP-SWITCH-A N° 1:</p> <p>ON: stop gate/s in opening and reverse travel in closing when cleared</p> <p>1 OFF: no stop in opening and reverse travel in closing when obstructed</p> <p>L1 ON = no obstacle, it goes off in case of obstruction</p>
<p>Key-switch:</p>	<p>NO and NC contacts to be connected to the respective terminals in the key- or button-switches.</p> <p>All of the possible setting combinations are described in the instructions sheets included with the respective control accessories</p>	<p>L4 OFF = no OPENING contact, it goes on whenever an opening pulse is given</p> <p>L5 OFF = no CLOSING contact, it goes on whenever a closing pulse is given</p> <p>L6 ON = STOP contact closed, it goes off whenever a stop pulse is given</p>
<p>Radio Contact (step by step mode):</p>	<p>Any NO connection to these two terminals will perform the following:</p> <ul style="list-style-type: none"> - Opening only: Dip 2=ON and Dip 5=OFF - Gate travel reversing by any pulse Dip 2=OFF and Dip 5=OFF - Step by step: Open-Stop-Close-Stop Dip 2=OFF and Dip 5=ON - No new pulse is accepted in opening. In Dwell phase and in closing any new pulse stops and reverses gate travel: Dip 2=ON and Dip 5=ON 	<p>DIP-SWITCH-A N°2 and N°5:</p> <p>ON: It does not stop and reverse gate travel in opening</p> <p>2 OFF: always stops & reverses in opening</p> <p>ON: step by step with intermediate stop</p> <p>5 OFF: gate travel reversed by any radio pulse</p> <p>L7 OFF = no RADIO contact, it goes on by any radio pulse</p>
<p>Indication lamp output 24V- max 3W:</p>	<p>Output for a 24V max 3W indication lamp showing the status of the system:</p> <ul style="list-style-type: none"> Lamp On = Gate open Lamp Off = Gate closed 0.5s (fast) flashing = gate closing 1s (normal) flashing = gate opening 	
<p>Limit switches:</p>	<p>IMPORTANT: if no limit switches are involved, link out terminals 8 - 9 - 10.</p> <p>Limit switches (L-sw.) must have normally closed contacts.</p>	<p>L8 ON = OFF on engaging L.sw. Closing</p> <p>L10 ON = OFF on engaging L.sw. Opening</p>



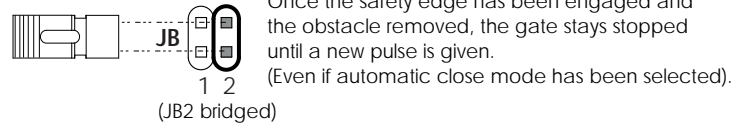
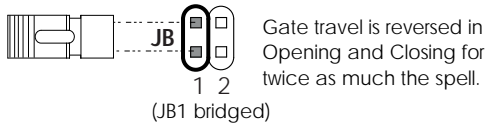
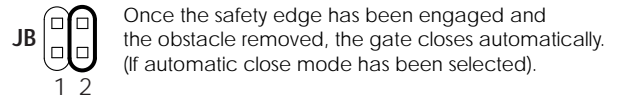
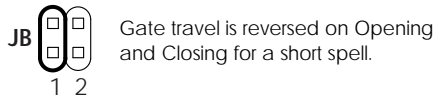

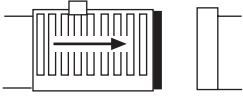
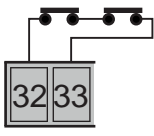
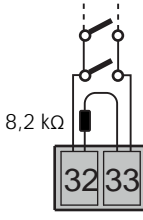
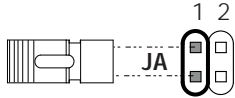

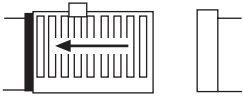
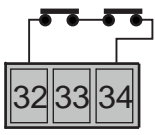
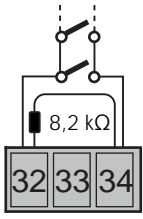
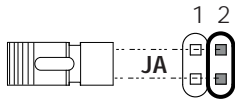
SAFETY EDGES

The two inputs, that are fitted to control the safety edges, are separated for the opening and closing phases. Also, it is possible to select the type of contact connected to them, either N.C. mechanical or 8,2 k resistive, by means of the two jumpers JA1 or JA2 (SELECT EDGE TYPE). Thanks to a dedicated microcontroller circuit separately fitted on to the board, the actual integrity and correct functioning of the safety system is constantly controlled. Any possible fault or loss of efficiency is signalled by the L33 and L34 LEDs keeping flashing.

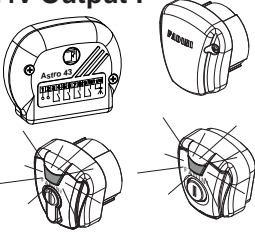
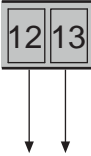
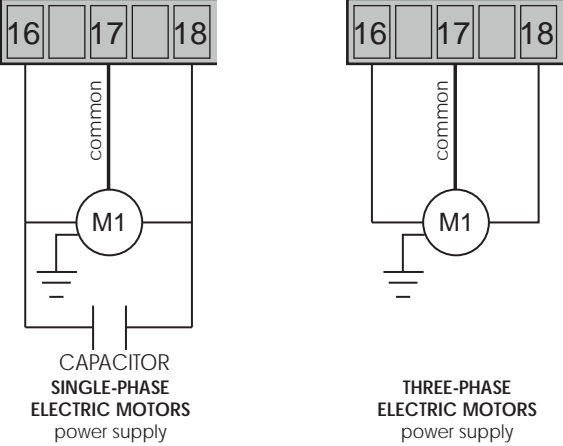
Selecting functioning:

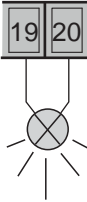
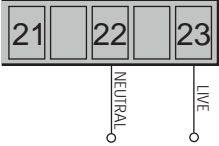
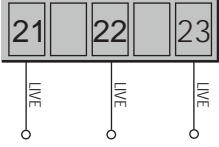

Accessory	Electrical connections	LED indications
<p>Safety edge in Closing:</p> 	 <p><i>In series if safety edges are mechanical, N.C.</i></p>  <p><i>In parallel if safety edges are resistive 8,2 kΩ</i></p> <p>Safety edge selection:</p>  <p>NC safety edge (JA1 bridged)</p>  <p>8,2KΩ Resistive safety edge</p>	 <p>Normally alight: whenever the safety edge is engaged, the LED goes off.</p>
<p>Safety edge in Opening:</p> 	 <p><i>In series if safety edges are mechanical, N.C.</i></p>  <p><i>In parallel if safety edges are resistive 8,2 kΩ</i></p> <p>Safety edge selection:</p>  <p>NC safety edge (JA2 bridged)</p>  <p>8,2KΩ Resistive safety edge</p>	 <p>Normally alight: whenever the safety edge is engaged, the LED goes off.</p>

Accessory	Electrical connections	Dip-Switch setting and LED indication of functions
<p>24V Output :</p> 	 <p>24Vac OUTPUT max load: No.3 Pairs photocells No.1 Radio receiver No.1LED Chis 37 / Chis-E 37 key-switch Instructions are attached to the related control accessories</p>	
<p>Output for motors:</p> <p>single-phase 230V max 735W - 1,0 HP</p> <p>or</p> <p>three-phase 400V max 1100W - 1,5 HP</p>	 <p>CAPACITOR SINGLE-PHASE ELECTRIC MOTORS power supply</p> <p>THREE-PHASE ELECTRIC MOTORS power supply</p>	 <p>RUN TIME OPEN - CLOSE 0s - 120s</p>  <p>DWELL TIME 1s - 220s</p>
<p>Flashing lamp 230V:</p> 	 <p>230Vac Output for flashing lamp max 25W</p>	<p>DIP-SWITCH-A N°4 and N°7</p> <p><input checked="" type="checkbox"/> ON: Pre-flashing before movement 4 OFF: No pre-flashing</p> <p><input checked="" type="checkbox"/> ON: Out of service in Dwell phase Automatic mode (by Dip 3 = ON) 7 OFF: Powered, ie. in service in Dwell phase Automatic mode (by Dip 3 = ON)</p>
<p>SINGLE- OR THREE-PHASE control board 230V - 400V power supply</p>	 <p>SINGLE-PHASE control board power supply 230V - 50/60Hz ± 10%</p>  <p>THREE-PHASE control board power supply 400V - 50/60Hz ± 10%</p>	 <p>230V ←</p>  <p>→ 400V</p>

Accessory

Electrical connections

Dip-Switch setting and LED indication of functions

Power connections to Pulin 3 LEDs:

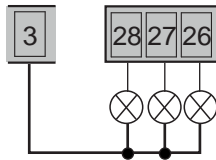
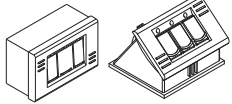

Terminals for the connections of the LEDs of the push buttons **Pulin 3**

24Vdc-5W Output:



Traffic lights plug-in card (Optional - Item No. 7282L):

The power supply of this card is independent from that of the control board: 230V 50Hz with an output of 100W at 230V each lamp.

Logic of operation:

- **GREEN** light = driveway **OPEN**
 - **RED** light = driveway **CLOSED**
 - **YELLOW** light = it switches on before light changes from green to red
- Note:** In **Pedestrians** mode the traffic light is always **RED**.

Dip-Switch A

- 4= **ON** Pre-flashing Enabled: traffic lights Red - Yellow - Green
- 4= **OFF** Pre-flashing Disabled: traffic lights Red - Green

Functioning with 2 lamps (Red and Green):

Dip-Switch A 4 = OFF

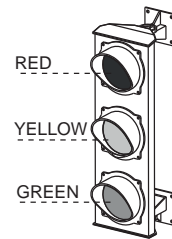
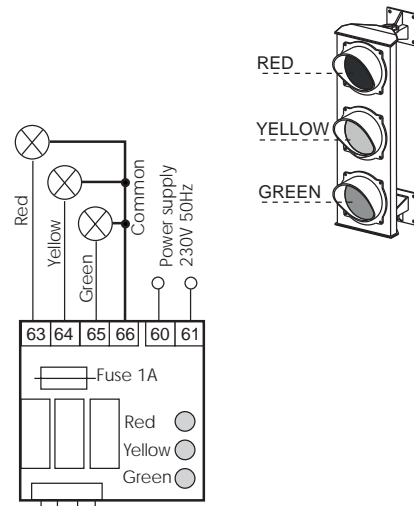

(Optional: Traffic lights plug-in card for 230V Lamps) **Item 7282L**

FUNCTIONS FOR SLIDING GATE OPENING

Description	Dip-Switch setting and LED indication of functions
<p>AUTOMATIC / SEMI-AUTOMATIC:</p> <p>Automatic Cycle: by one pulse from the open command the gate opens and stops in Dwell mode for the time as pre-set on the Dwell Trimmer. When this time expires the gate closes automatically.</p> <p>Semi-automatic Cycle: by one pulse from the open command the gate opens and stops in fully open position. To close the gate, a close pulse is needed.</p>	<p>DIP-SWITCH-A N°3:</p> <div style="border: 1px solid black; padding: 5px;"> <p><input type="checkbox"/> ON: Automatic closing</p> <p><input checked="" type="checkbox"/> 3 OFF: Semi-automatic, closing by pulse</p> </div> <p> Dwell Trimmer: adjust dwell time on automatic mode from 1s up to 220s</p>
<p>PEDESTRIAN OPENING:</p> <p>With the gate in fully closed position, a pulse to terminals P-P operates the gate for pedestrians.</p> <p>(On pedestrian mode, it is advisable to set Dip-A N°3 = ON for automatic re-closing).</p> <p>The function "Pedestrian Opening" is not in service during the first operation cycle, after a power failure.</p>	<p> PEDESTRIAN OPENING 1s - 45s</p> <p><input type="radio"/> LO OFF = no pedestrian contact given, it goes on by pulsing for pedestrians</p> <p> OPEN PEDESTRIANS</p>
<p>RE-CLOSING BY PASSING ACROSS THE PHOTOCELLS: in opening and dwell cycles (DIP-A N°3=ON)</p> <p>Gate is automatically closed after 3s from passing between the photocells.</p>	<p>DIP-SWITCH-A N°8:</p> <div style="border: 1px solid black; padding: 5px;"> <p><input type="checkbox"/> ON: Automatic closing on passing across the photocells after 3 seconds</p> <p><input checked="" type="checkbox"/> 8 OFF: No automatic closing on passing across the photocells</p> </div>
<p>DSA: PHOTOCCELL AUTOMATIC CONTROL:</p> <p>For the DSA control (Device for Safety Auto-test) it is necessary to connect only the photocell transmitters (TX) to this output and select Dip-A No.9=ON: if this function is enabled, ELPRO 37 checks that all the connected photocell devices are cleared from obstacles and properly working before starting any door/gate movements, otherwise the door/gate is not started.</p>	<p> 24V ac Output for photocell TX enabled for DSA control</p> <p>DIP-SWITCH-B N°9:</p> <div style="border: 1px solid black; padding: 5px;"> <p><input type="checkbox"/> ON: <u>DSA safety control</u> enabled</p> <p><input checked="" type="checkbox"/> 9 OFF: <u>DSA safety control</u> disabled</p> </div>
<p>DEADMAN (HOLD-ON-SWITCHED) CONTROL:</p> <p>The open/close operations are achieved by "holding on a command switched" (the relays are not self-holding) and consequently the user must be actively present during gate movements until the push-button or the key-switch is released.</p>	<p>DIP-SWITCH-B N°6:</p> <div style="border: 1px solid black; padding: 5px;"> <p><input type="checkbox"/> ON: Deadman control enabled</p> <p><input checked="" type="checkbox"/> 6 OFF: Deadman control disabled</p> </div>
<p>PARTY FUNCTION</p> <p>OPEN-AND-HOLD BY EXTERNAL CLOCK:</p> <p>Connect the Clock NO contact to OPEN terminals No. 4 and COMMON No. 3, and activate automatic closing by setting Dip-Switch No. 3=ON.</p> <p><u>How it works:</u> program the opening time on the clock. At the preset time, the gates will open and remain open (the flashing light will turn off) and <u>will not accept any other command</u> (not even radio commands) until the time set on the clock expires. <u>When this time expires the gates close automatically after the pause time.</u></p> <p>While the gates are held open by the time set on the "clock", the indication light keeps giving out two consecutive flashes followed by a long pause.</p>	<p> External Clock</p> <p>DIP-SWITCH-A N°3:</p> <div style="border: 1px solid black; padding: 5px;"> <p><input type="checkbox"/> ON: Automatic closing</p> <p><input checked="" type="checkbox"/> 3</p> </div> <p>IMPORTANT: use always and only with Dip-A N°3= ON</p>





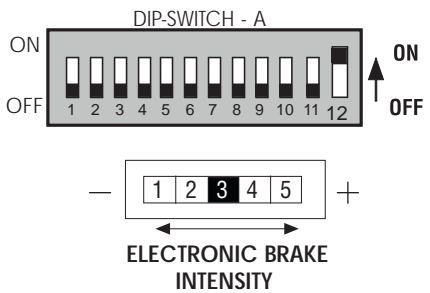





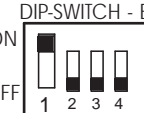
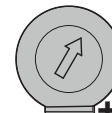

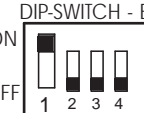
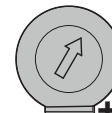

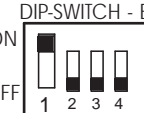
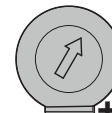

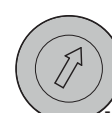

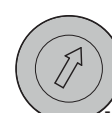

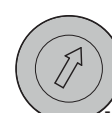
ELECTRONIC BRAKE FUNCTION

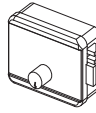
ATTENTION: In cases a motor with mechanical brake is used or a control board ELPRO 10 is replaced, the DIP-switch No.12 has to be in OFF.

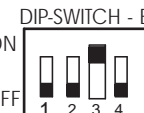
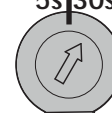
<i>Description</i>	<i>Dip - Switch and trimmer of functions</i>
<p>To enable the electronic brake function set the Dip-switch-A No. 12 in ON and adjust the electronic brake intensity by the selector in the figure.</p> <p><u>The factory preset adjustments are suitable for most installations.</u></p> <p>For a more precise regulation of the electronic brake, it is possible to set up various braking parameters by following the <i>advanced instructions</i> below.</p>	

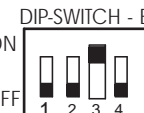
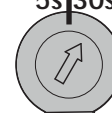
ADVANCED INSTRUCTIONS FOR THE ELECTRONIC BRAKE

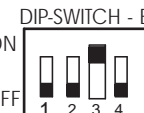
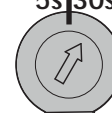
ATTENTION: the electronic brake is to be enabled by putting the Dip-switch No.12 in ON

<i>Function</i>	<i>Description</i>	<i>Dip - Switch and trimmer of functions</i>						
Braking time:	<p>To adjust the braking duration it is necessary to put the Dip-Switch B No.1 in ON and set the braking time by Trimmer T.FUN.</p> <p><u>Once the calibration of braking duration is completed put all Dip-switches B in OFF.</u></p>	<p style="text-align: center;"><i>Operations</i></p> <table border="1" style="width: 100%;"> <tr> <th style="width: 33%;">I</th> <th style="width: 33%;">II</th> <th style="width: 33%;">III</th> </tr> <tr> <td style="text-align: center;">  </td> <td style="text-align: center;"> <p>T.FUN 0s - 2s</p>  </td> <td style="text-align: center;">  </td> </tr> </table>	I	II	III		<p>T.FUN 0s - 2s</p> 	
I	II	III						
	<p>T.FUN 0s - 2s</p> 							
Additional stop time after braking when safety devices are activated:	<p>To set the additional stop time after braking it is necessary to put the Dip-switch B No.2 in ON and adjust the stop time by mean of trimmer T.FUN.</p> <p><u>Once the calibration of additional stop time is completed put all Dip-switches B in OFF.</u></p> <p><u>N.W.: this function is enabled and adjustable even if the electronic brake is disabled. It allows more time for the gate to reverse the travel direction when safety devices as photocells or sensitive edges are engaged, so as proper reverse movement is achieved, especially for single-phase motors where high inertia is involved.</u></p>	<p style="text-align: center;"><i>Operations</i></p> <table border="1" style="width: 100%;"> <tr> <th style="width: 33%;">I</th> <th style="width: 33%;">II</th> <th style="width: 33%;">III</th> </tr> <tr> <td style="text-align: center;">  </td> <td style="text-align: center;"> <p>T.FUN 0s - 3s</p>  </td> <td style="text-align: center;">  </td> </tr> </table>	I	II	III		<p>T.FUN 0s - 3s</p> 	
I	II	III						
	<p>T.FUN 0s - 3s</p> 							
<p>Electric lock:</p>  <p>or Courtesy lamp:</p> 	<p>For setting working time of the electric lock or courtesy lamp connected to the 14-15 outputs, put the Dip-switch B No.3 in ON and adjust the working time by mean of trimmer T.FUN.</p> <p><i>In this mode, the trimmer T.FUN enables you adjust electric lock working time from 0s to 5s on the first half of trimmer travel. On the second half of trimmer travel it allows you to connect a relé to 14-15 outputs for a courtesy lamp working time control, adjustable from 30s to 5 min.</i></p> <p><u>Once the electric lock or courtesy lamp working time is set, put all Dip-switches B in OFF.</u></p> <div style="display: flex; align-items: center; margin-top: 10px;"> <div style="border: 1px solid black; padding: 2px; margin-right: 10px;">14 15</div> <div> <p>12Vac power supply output for electric lock 15VA max or relé for courtesy lamp control</p>  </div> </div>	<p style="text-align: center;"><i>Operations</i></p> <table border="1" style="width: 100%;"> <tr> <th style="width: 33%;">I</th> <th style="width: 33%;">II</th> <th style="width: 33%;">III</th> </tr> <tr> <td style="text-align: center;">  </td> <td style="text-align: center;"> <p>T.FUN 5s 30s</p>  <p>0s 5min</p> </td> <td style="text-align: center;">  </td> </tr> </table>	I	II	III		<p>T.FUN 5s 30s</p>  <p>0s 5min</p>	
I	II	III						
	<p>T.FUN 5s 30s</p>  <p>0s 5min</p>							

ATTENTION: avant de faire les raccordements électriques, assurez-vous que le sélecteur de la tension électrique 230V ou 400V soit correctement positionné.
Si on utilise le moteur avec frein mécanique ou on remplace un ELPRO 10, le Dip-switch Nr.12 doit être sur OFF.

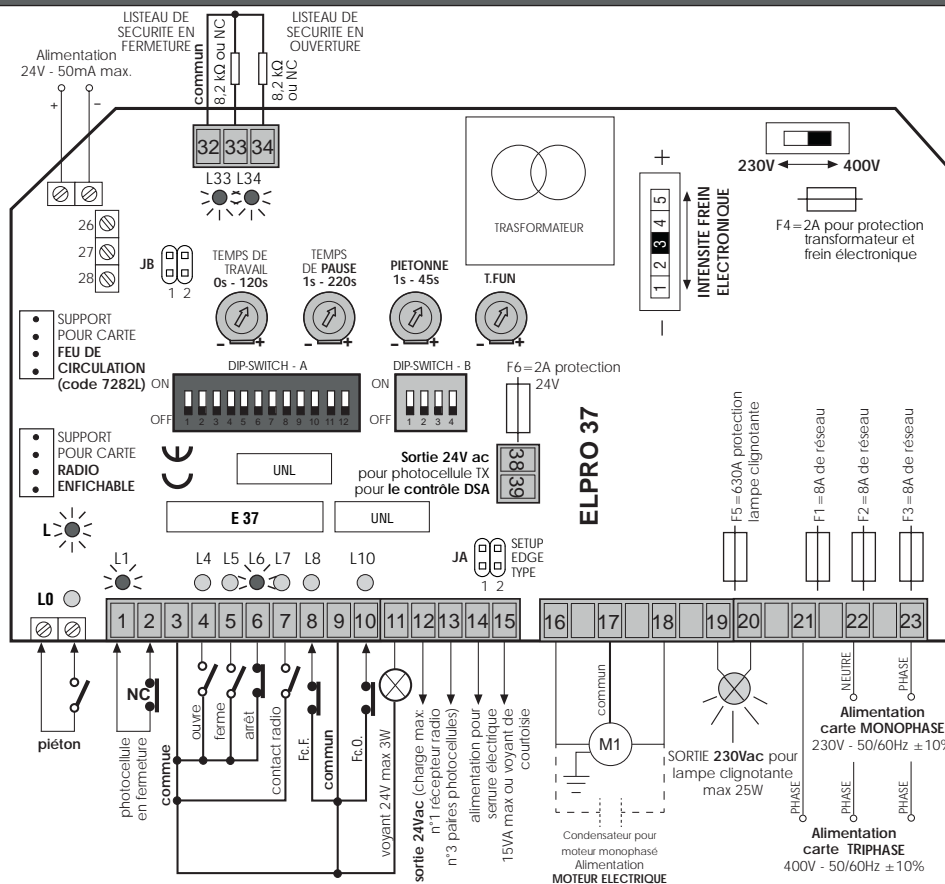

REMARQUE:
Les leds verts doivent toujours être allumées.

Description générale: Le Programmeur électronique ELPRO 37 a été réalisé comme une solution pour la gestion d'un coulisseau automatisé avec ou sans frein électronique et fin de course. L'ELPRO 37 est alimenté à 230V 50/60Hz monophasé ou 400V 50/60Hz triphasé et il respecte les normes de Sécurité Basse Tension 2006/95 CE et Compatibilité Electromagnétique 2004/108/CE. Nous conseillons, donc, que l'installation soit réalisée par un technicien qualifié dans le respect des normes de sécurité en vigueur. L'Entreprise de construction ne s'assume pas des responsabilités en ce qui concerne l'usage incorrect du programmeur et elle se réserve le droit d'apporter des modifications au programmeur en n'importe quel moment.

NOTICES IMPORTANTES POUR LA CORRECTE INSTALLATION ET LE CORRECTE FONCTIONNEMENT:

- Le Programmeur doit être installé dans un lieu sec et abrité. Sur le boîtier universel FADINI et sur le boîtier commercial il y a des trous pour la fixation
- Assurez-vous que l'alimentation du programmeur électronique soit 230V ±10% ou 400V ±10%
- Assurez-vous que l'alimentation du Moteur Electrique soit 230V ±10% ou 400V ±10%
- Augmentez-vous la section des fils pour des distances supérieures aux 50 mètres
- Appliquez-vous à l'alimentation du programmeur un interrupteur Magnéto-Thermique Différentiel du type 0,03A à haute sensibilité
- Pour l' Alimentation, le Moteur Electrique, la Lampe clignotante utilisez des fils avec section de 1,5mm² jusqu'à 50m de distance
- Pour les Fins de course, les Photocellules, les Boîtes à boutons poussoirs et les accessoires utilisez des câbles avec fils de 1mm²
- Si on n'utilise pas les Photocellules, faites un pontage entre les bornes 1 et 2
- Si on n'utilise aucune Boîte à boutons poussoirs, faites un pontage entre les bornes 3 et 6
- Le Trimmer du Temps de Travail Ouvre/Ferme doit être toujours supérieur au temps effectif de la course du portail

N.B: Pour d'applications comme l'allumage des lumières, caméras, ecc. utilisez des Relais Statiques pour éviter de créer brouillages au microprocesseur

Led de Contrôle:

- L Allumée** = Présence de Tension de réseau 230V ou 400V et intégrité fusibles F1,F2,F3, F4, F5,F6
- L0 Allumée** = Piéton, s'allume à chaque commande piétonne
- L1 Allumée** = Paire Photocellules, sans obstacle
- L4 Eteinte** = Ouvre, s'allume à l'impulsion de la commande d'ouverture
- L5 Eteinte** = Ferme, s'allume à l'impulsion de la commande de fermeture
- L6 Allumée** = Arrêt, s'éteint à l'impulsion de la commande d'arrêt
- L7 Eteinte** = Radio, s'allume à chaque impulsion de l'émetteur et contact radio
- L8 Allumée** = S'éteint à Fc.F. utilisé M1
- L10 Allumée** = S'éteint à Fc.O. utilisé M1
- L33 Allumée** = Listeau de sécurité en fermeture, sans obstacle
- L34 Allumée** = Listeau de sécurité à photocellule en ouverture, sans obstacle

Symboles

- Contact NO
- Contact NF
- Contact résistive 8,2 k ou NF
- Led Allumée
- Led Eteinte
- Voyant ou lampe
- Lampe clignotante

EN CAS DE MANQUE DE FONCTIONNEMENT

- Assurez-vous que l'alimentation du programmeur électronique soit 230V ±10% ou 400V ±10%
- Assurez-vous que l'alimentation du Moteur Electrique soit 230V ±10% ou 400V ±10%
- Contrôlez-vous tous les fusibles
- Contrôlez-vous que les Photocellules soient en contact fermé
- Contrôlez-vous qu'il n'y ait pas une chute de tension entre le Programmeur Elpro et le Moteur Electrique
- Contrôlez-vous tous les contacts NF du programmeur
- Contrôlez-vous tous les raccordements et le fonctionnement des fin de course.

ATTENTION: avant de faire les raccordements électriques, assurez-vous que le sélecteur de la tension électrique 230V ou 400V soit correctement positionné.
Si on utilise le moteur avec frein mécanique ou on remplace un ELPRO 10, le Dip-switch Nr.12 doit être sur OFF.

Dip-Switch A

- 1 = ON Photocellule arrête à l'ouverture
- 2 = ON Radio n'inverse pas à l'ouverture
- 3 = ON Ferme en automatique
- 4 = ON Pré-clignotement Actif
- 5 = ON Radio pas-pas
- 6 = ON Homme mort
- 7 = ON Lampe clignotante éteinte en pause en automatique
- 8 = ON Referme en Ouverture et en pause après passage devant les photocellules
- 9 = ON Contrôle DSA photocellules émetteurs avant chaque manœuvre
- 10 = ON Photocellules libre d'obstacle avant chaque mouvement
- 11 = libre
- 12 = ON Freinage électronique actif

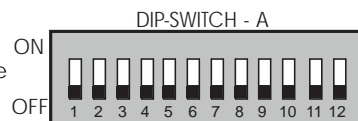

Dip-Switch B

- 1 = ON règle la durée du freinage
- 2 = ON règle le temps d'arrêt additionnel après le freinage à l'intervention des photocellules
- 3 = ON règle la durée de fonctionnement serrure électrique ou lampe de courtoisie
- 4 = OFF libre



Accessoire	Raccordements électriques	Dip-Switch et LED de signalisation des fonctions
<p>Photocellule ouverture:</p>	<p>tous les contacts NF des accessoires de sécurité comme les Photocellules (récepteurs) doivent être raccordés en série aux bornes 1 et 2</p> <p>sortie 24Vac charge max: n°1 récepteur radio n°3 paires photocellules</p>	<p>DIP-SWITCH-A N° 1:</p> <ul style="list-style-type: none"> ON: arrête en ouverture et inverse en fermeture avec l'obstacle enlevé 1 OFF: n'arrête pas en ouverture et inverse en fermeture avec la présence de l'obstacle <ul style="list-style-type: none"> L1 Allumée= aucun obstacle, elle s'éteint avec la présence de l'obstacle
<p>Sélecteur à clé:</p>	<p>contacts NO et NF à raccorder aux respectives bornes des sélecteurs ou des boîtes à boutons poussoirs. Toutes les possibles configurations sont jointes aux respectifs accessoires de commande.</p>	<ul style="list-style-type: none"> L4 Eteinte= aucun contact OUVRE, elle s'allume à chaque impulsion d'ouverture L5 Eteinte= aucun contact FERME, elle s'allume à chaque impulsion de fermeture L6 Allumée= contact d'ARRET fermé, elle s'éteint à chaque contact d'arrêt
<p>Contact Radio (avec fonction pas-pas):</p>	<p>raccordant un contact NO entre les deux bornes on peut obtenir à chaque impulsion:</p> <ul style="list-style-type: none"> - Seulement ouverture: Dip 2=ON et Dip 5=OFF - Inversion de marche à chaque impulsion Dip 2=OFF et Dip 5=OFF - Pas-Pas: Ouvre-Arrêt-Ferme-Arrêt Dip 2=OFF et Dip 5=ON <p>- En phase d'ouverture il n'accepte aucune commande. En pause et en fermeture, à chaque commande, il exécute l'arrêt avec l'inversion de marche: Dip 2=ON et Dip 5=ON</p>	<p>DIP-SWITCH-A N°2 et N°5:</p> <ul style="list-style-type: none"> ON: En ouverture n'inverse pas et n'arrête pas 2 OFF: En ouverture arrête et inverse toujours ON: Pas-pas avec arrêt intermédiaire 5 OFF: Inverse le mouvement à chaque impulsion radio L7 Eteinte= aucun contact RADIO, elle s'allume à chaque impulsion du contact radio
<p>Sortie Voyant de Signalisation de 24V - max 3W:</p>	<p>Sortie pour un éventuel voyant 24V max 3W pour la signalisation de l'état de l'automatisme: Voyant Allumé = Portail Ouvert Voyant Eteint = Portail Fermé Clignotement 0,5s (rapide) = mouvement de fermeture Clignotement 1s (normal) = mouvement d'ouverture</p>	
<p>Fin de course:</p>	<p>IMPORTANT: si les fins de course ne sont pas utilisés, faire un pontage entre les entrées 8 - 9 - 10. Utiliser Fc. normalement fermé</p>	<ul style="list-style-type: none"> L8 Allumée= éteinte à Fc Fermeture L10 Allumée= éteinte à Fc Ouverture

LISTEAUX DE SECURITE







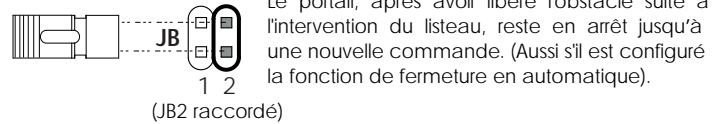
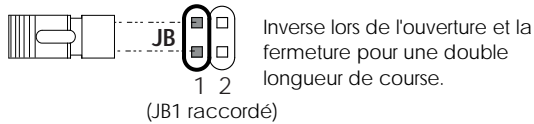
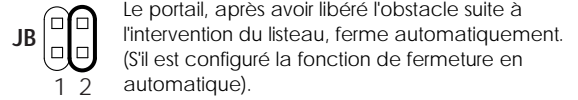
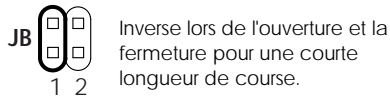

Les deux entrées dédiées aux listeaux sont séparés, l'un pour l'ouverture et l'autre pour la fermeture. Avec les deux pont de passage JA1 et JA2 (SELECT EDGE TYPE), on peut aussi choisir le type de contact connectée: mécanique NF ou résistif 8,2 kΩ.

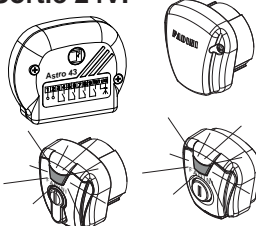
Grâce à un microcontrôleur dédié aux listeaux sur la plaque, on vérifie constamment l'intégrité et la fonctionnalité du système de sécurité. Un possible défaut ou perte d'efficacité est signalé par le clignotement continu des LED L33 et L34.

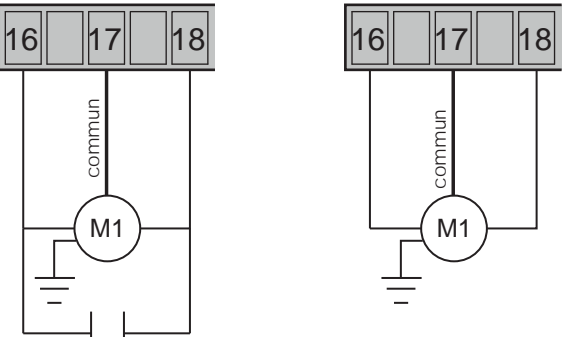
Sélection du fonctionnement:

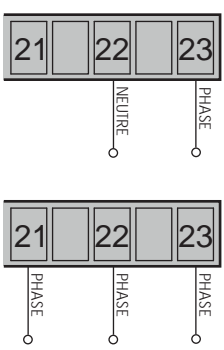

Accessoire	Raccordements électriques	LED de signalisation
<p>Listeau de sécurité en Fermeture:</p>	<p><i>En série si listeaux mécaniques NF</i> <i>En parallèle si listeaux résistifs 8,2 kΩ</i></p> <p>Sélection typologie de listeau utilisé:</p> <p>Listeau NF (JA1 raccordé) Listeau résistive 8,2 kΩ</p>	<p>Normalement allumé: lorsque il y a l'intervention du listeau, le voyant s'éteint.</p>
<p>Listeau de sécurité en Ouverture:</p>	<p><i>En série si listeaux mécaniques NF</i> <i>En parallèle si listeaux résistifs 8,2 kΩ</i></p> <p>Sélection typologie de listeau utilisé:</p> <p>Listeau NF (JA2 raccordé) Listeau résistive 8,2 kΩ</p>	<p>Normalement allumé: lorsque il y a l'intervention du listeau, le voyant s'éteint.</p>

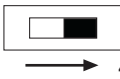
Accessoire	Raccordements électriques	Dip-Switch et LED de signalisation des fonctions
<p>Sortie 24V:</p> 	 <p>SORTIE 24Vac pour charge max: n°3 Paires Photocellules n°1 Récepteur radio n°1 Led sélecteur Chis 37 / Chis-E 37 Toutes les notices d'instructions sont jointes aux respectifs accessoires de commande</p>	
<p>Sortie pour moteurs:</p> <p>monophasé 230V max 735W - 1,0 HP</p> <p>ou</p> <p>triphasé 400V max 1100W - 1,5 HP</p>	 <p>CONDENSATEUR Alimentation MOTEURS ELECTRIQUES MONOPHASE</p> <p>Alimentation MOTEURS ELECTRIQUES TRIPHASE</p>	 <p>TEMPS DE TRAVAIL OUVRE-FERME 0s - 120s</p>  <p>TEMPS DE PAUSE 1s - 220s</p>
<p>Lampe clignotante 230V:</p> 	 <p>SORTIE 230Vca pour lampe clignotante max 25W</p>	<p>DIP-SWITCH-A N°4 et N°7</p> <p><input checked="" type="checkbox"/> ON: Pré-clignotement avant le mouvement 4 OFF: Sans pré-clignotement</p> <p><input checked="" type="checkbox"/> ON: Lampe clignotante désactivée en pause en Automatique (avec Dip 3= ON) 7 OFF: Clignote pendant la pause en Automatique (avec Dip 3= ON)</p>
<p>Alimentation carte 230V - 400V:</p> <p>MONOPHASE ou TRIPHASE</p>	 <p>Alimentation carte MONOPHASE 230V - 50/60Hz ± 10%</p> <p>Alimentation carte TRIPHASE 400V - 50/60Hz ± 10%</p>	 <p>230V ←</p>  <p>→ 400V</p>

Accessoire

Raccordements électriques

Dip-Switch et LED de signalisation des fonctions

Raccordement Pulin 3:

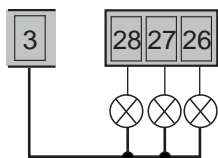
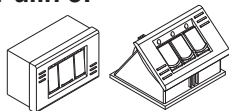

bornier pour le raccordement des Leds de la boîte à boutons poussoirs Pulin 3

Sortie 24Vdc-5W:



SORTIE 24Vdc - 5W max

Carte enfichable feu de circulation (Optional - cod.7282L):

L'alimentation de la carte est indépendante de celle du programmeur: 230V 50Hz avec sortie de 100W à 230V pour chaque ampoule.

Logique de Fonctionnement:

- Feu VERT= passage OUVERT
- Feu ROUGE= passage FERME
- Feu JAUNE= s'allume juste avant le passage du feu Vert au feu Rouge

Note: lorsque le fonctionnement Piétons est actif le feu reste ROUGE.

Dip-Switch A

- 4= ON Pré-clignotement Actif: feu de circulation Rouge - Jaune - Vert
- 4= OFF Pré-clignotement Désactivé: feu de circulation Rouge - Jaune

Fonctionnement avec 2 lampes (Rouge et Vert):

Dip-Switch A 4 = OFF

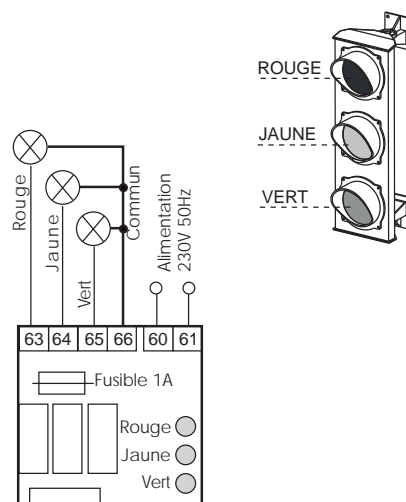

(En option: Carte enfichable pour feu de circulation lampe à 230V) **code 7282L**

FONCTIONS POUR L'OUVERTURE COULISSANTE

Description

Dip - Switch et signalisation LED des fonctions

AUTOMATIQUE / SEMI-AUTOMATIQUE:

Cycle Automatique: à la commande ouvre, le portail s'ouvre et s'arrête en Pause pour le temps mémorisé dans le **Trimmer Pause**. Expiré ce temps, le portail se referme automatiquement.

Cycle Semi-automatique: à la commande ouvre, le portail s'ouvre et s'arrête en position d'ouverture. Pour la fermeture du passage, il faut donner l'impulsion de fermeture.

DIP-SWITCH-A N°3:

- ON: Ferme en Automatique
- 3 OFF: Semi-automatique



Trimmer Pause: on règle le temps de pause en modalité Automatique de 1s jusqu'à 220s

OUVERTURE PIETONNE:

L'ouverture piétonne avec portail fermé est possible à travers la commande sur contacts P-P.

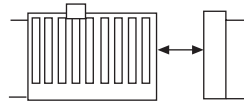

(On conseille l'utilisation de l'ouverture piétonne avec Dip-A N°3 = ON pour la refermeture automatique).

La fonction "Ouverture piétonne" n'est pas actif pendant le premier cycle de fonctionnement à la suite de l'absence de tension d'alimentation.



OUVERTURE PIETONNE
1s - 45s

- L0 Eteinte = aucun contact piéton, s'allume à la commande piétons



REFERMURE AU PASSAGE DES PHOTOCELULES: en phase d'ouverture et en pause (avec DIP-A N°3=ON):

Fonction qui permet la refermeture automatique du portail après 3s du passage à travers le faisceau des photocellules.

DIP-SWITCH-A N°8:

- ON: Refermeture automatique après 3 secondes du passage des photocellules
- 8 OFF: Aucune refermeture automatique du passage des photocellules

DSA: CONTROLE AUTOMATIQUE DES PHOTOCELULES

Pour le contrôle DSA (Dispositif Sécurité Autotest) il faut raccorder à cette sortie **seulement les projecteurs des photocellules** et il faut sélectionner le **Dip-A N°9=ON**: avant chaque mouvement du portail, si cette fonction est en service, l'Elpro 37 contrôlent que tous les dispositifs photocellules raccordés soient libres d'obstacles et correctement fonctionnants. En cas contraire le portail ne part pas.



Sortie 24V ca pour photocellule TX pour le contrôle DSA

DIP-SWITCH-B N°9:

- ON: Active le contrôle des sécurités DSA
- 9 OFF: Désactive le contrôle des sécurités DSA

HOMME MORT:

On obtient la commande d'ouverture et fermeture "à action maintenue" (sans autotenuue dans les Relais), donc il y a la présence active d'un opérateur pendant tout le mouvement de l'automation jusqu'à la relâche de la touche ou de la clé du sélecteur.

DIP-SWITCH-B N°6:

- ON: Active la fonction Homme Mort
- 6 OFF: Désactive la fonction Homme Mort

PARTY FUNCTION

OUVERTURE PAR HORLOGE EXTERNE:

Raccorder en parallèle le contact NO de l'Horloge avec le bornier n°4 OUVRE et n°3 COMMUN, activant la refermeture automatique avec le Dip-Switch n°3=ON.

Fonctionnement: mémoriser l'horaire d'ouverture dans l'horloge. A l'heure mémorisée le portail s'ouvre, en restant ouvert (la lampe clignotante s'éteint) et il n'acceptera plus aucune commande (même radio) jusqu'à l'expiration du temps rentré dans l'horloge. A l'expiration de ce temps, après le temps de pause, suivra la fermeture automatique. Pendant la pause à portail ouvert avec la commande "horloge", le voyant de signalisation émet deux clignotements rapprochés suivis d'une pause plus longue.

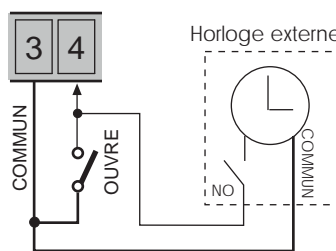

DIP-SWITCH-A N°3:

- ON: Ferme en Automatique
- 3 OFF: Semi-automatique

IMPORTANT: utiliser toujours et seulement avec le Dip-A N°3= ON





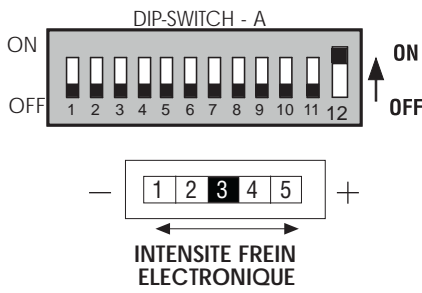





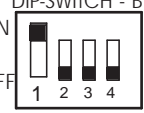
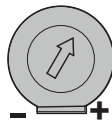

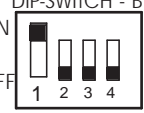
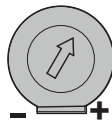

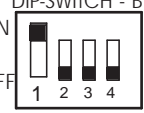
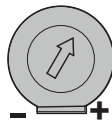

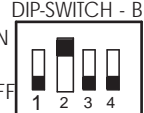

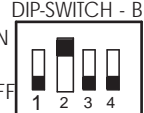

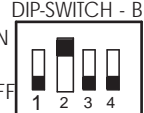

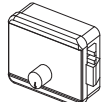

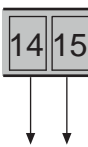
FONCTIONS POUR LE FREIN ELECTRONIQUE

ATTENTION:
Si on utilise le moteur avec frein mécanique ou on remplace un ELPRO 10, le Dip-switch Nr.12 doit être sur OFF.

Description	Dip - Switch et signalisation LED des fonctions
<p>Pour activer le frein électronique il est suffisant positionner le Dip-Switch-A Nr. 12 sur ON et régler l'intensité du frein électronique avec le sélecteur indiqué dans la figure.</p> <p><u>Les réglages d'usine par défaut conviennent pour la plupart des installations.</u></p> <p>Pour un réglage plus sensible du frein électronique il est possible régler les différents paramètres du freinage selon les indications contenues dans la section <i>réglages avancés du frein électronique</i>.</p>	

REGLAGES AVANCES DU FREIN ELECTRONIQUE

ATTENZIONE: le frein électronique doit être activé par le dip-switch n. 12

Fonction	Description	Dip - Switch et trimmer des fonctions						
Durée du freinage:	<p>On règle la durée du freinage électronique en positionnant le Dip-Switch B Nr. 1 sur ON et en réglant le temps de freinage avec le trimmer T.FUN.</p> <p><u>Une fois l'étalonnage de la Durée de freinage achevé, mettre tous les Dip-switches B sur OFF.</u></p>	<p><i>Operations</i></p> <table border="1"> <thead> <tr> <th>I</th> <th>II</th> <th>III</th> </tr> </thead> <tbody> <tr> <td></td> <td>T.FUN 0s - 2s </td> <td></td> </tr> </tbody> </table>	I	II	III		T.FUN 0s - 2s 	
I	II	III						
	T.FUN 0s - 2s 							
Temps additionnel de fermeture après le freinage:	<p>Pour le réglage du temps additionnel de fermeture après le freinage, positionner le Dip-switch B Nr. 2 sur ON et régler la durée de fermeture avec le trimmer T.FUN.</p> <p><u>Lorsque l'étalonnage du temps additionnel de fermeture est terminé positionner sur OFF tous les Dip-switches B.</u></p> <p>Remarque: cette fonction reste active et modifiable même lorsque le frein électronique est désactivé. Elle vous permet d'augmenter le temps d'inversion de la course lors de l'engagement des photocellules ou listeaux de sécurité, de manière à assurer inversions sûres, notamment pour moteurs monophasés à forte inertie.</p>	<p><i>Operations</i></p> <table border="1"> <thead> <tr> <th>I</th> <th>II</th> <th>III</th> </tr> </thead> <tbody> <tr> <td></td> <td>T.FUN 0s - 3s </td> <td></td> </tr> </tbody> </table>	I	II	III		T.FUN 0s - 3s 	
I	II	III						
	T.FUN 0s - 3s 							
<p>Serrure électrique:</p>  <p>ou Lampe de courtoisie:</p> 	<p>Pour régler le temps de fonctionnement de la serrure électrique ou de la lampe de courtoisie raccordée à la sortie 14-15, positionner sur ON le Dip-switch B Nr.3 et régler la durée de fonctionnement avec le trimmer T.FUN.</p> <p><i>Avec le trimmer T.FUN en cette modalité il est possible le réglage du temps d'activation d'une serrure électrique de 0s jusqu'à 5s pendant la première moitié de la course du trimmer. Pendant la deuxième moitié de la course il vous permet de lier à la sortie 14-15 un relais pour la gestion d'une lampe de courtoisie réglable de 30s jusqu'aux 5 min.</i></p> <p><u>Lorsque le réglage du temps de fonctionnement de la serrure électrique ou de la lampe de courtoisie est terminé, positionner sur OFF tous les Dip-switches B.</u></p> <div style="display: flex; align-items: center;"> <div style="border: 1px solid black; padding: 2px; margin-right: 10px;">14 15</div> <div> <p>Sortie alimentation 12Vac pour serrure électrique 15VA max ou relais pour la gestion d'une lampe de courtoisie</p>  </div> </div>	<p><i>Operations</i></p> <table border="1"> <thead> <tr> <th>I</th> <th>II</th> <th>III</th> </tr> </thead> <tbody> <tr> <td></td> <td>T.FUN 5s 30s  0s 5min</td> <td></td> </tr> </tbody> </table>	I	II	III		T.FUN 5s 30s  0s 5min	
I	II	III						
	T.FUN 5s 30s  0s 5min							

! ACHTUNG: bevor die Elektroanschlüsse auszuführen, sicherstellen dass der Spannungsschalter 230V oder 400V korrekt eingestellt ist.
Im Fall ein Motor mit mechanischer Bremse verwendet oder eine Steuerung ELPRO 10 ersetzt wird muss der Dip-Schalter Nr.12 auf OFF gelassen werden.

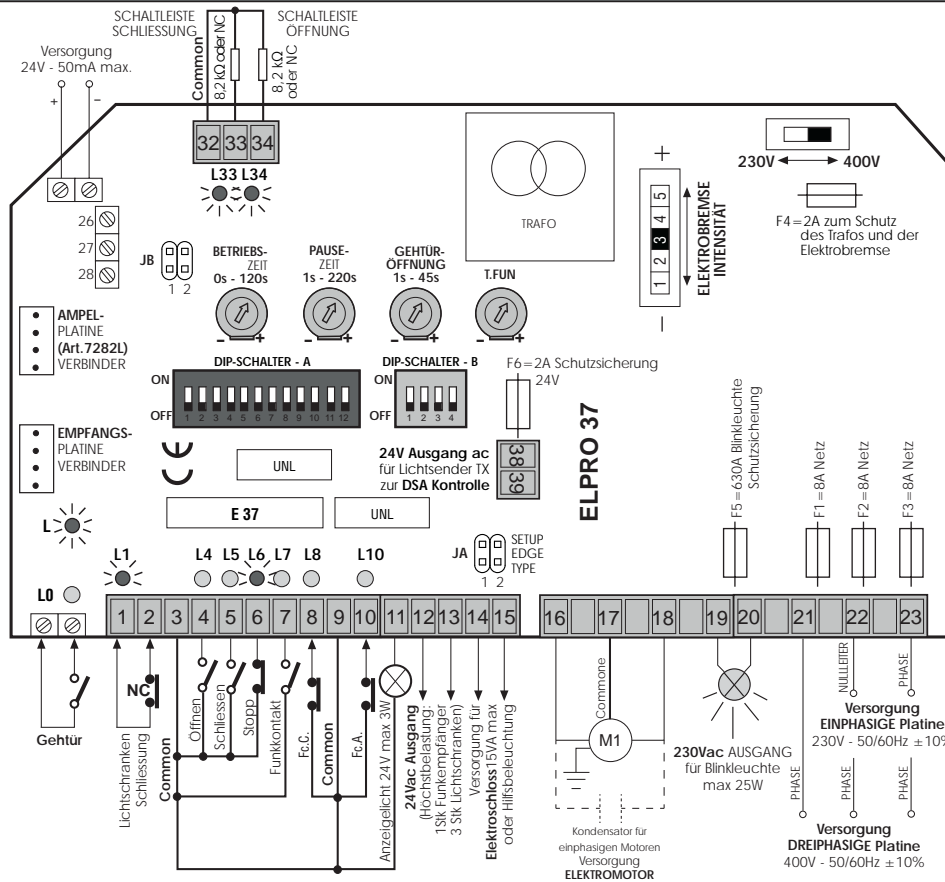

NOTABENE:
Die grünen LEDs müssen immer an sein

Allgemeine Beschreibung: Die elektronische Steuerung ELPRO 37 wurde konstruiert, um eine zuverlässige Lösung zur Bedienung von Schiebetorantrieben, mit oder ohne Elektrobremse und Endschalter. Einphasige 230V 50/60Hz oder dreiphasige 400V 50/60Hz, ELPRO 37 entspricht den Sicherheitsnormen, was Niederspannung 2006/95 CE und elektromagnetische Kompatibilität 2004/108/CE betrifft. Die Installation muss durch qualifizierte Fachleute gemäss den gültigen Vorschriften erfolgen. Die Herstellerfirma übernimmt keine Haftung für eine falsche Verwendung des Apparats und behält sich vor, Änderungen und Verbesserungen an der Steuerung vorzunehmen.

WICHTIG FÜR DIE INSTALLATION UND DEN EINWANDFREIEN BETRIEB:

- Die Steuerung muss an einem trockenen und geschützten Ort installiert werden; geeignete Löcher auf dem Universal-Kasten Fadini sind für die Befestigung vorgesehen und falls ein Kasten, auf dem Markt gekauft, verwendet wird, muss dieser für die Installation angepasst werden.
- Prüfen Sie die Versorgung an die elektronische Steuerung, sie muss 230V ± 10% oder 400V ± 10%.
- Prüfen Sie die Versorgung an den E-Motor, sie muss 230V ± 10% oder 400V ± 10%.
- Für Abstände über 50 Meter wird es empfohlen Kabel mit Drähten es höheren Querschnitts zu verwenden.
- Der Steuerung einen hochempfindlichen magneto-thermischen Differenzialschalter Typ 0,03A vorschalten.
- Für Versorgung, E-Motor und Blinkleuchte Kabel mit Drähten von 1,5 mm² Durchmesser bis zum Abstand von 50m verwenden
- Für Endschalter, Lichtschranken, Drucktastentafel und Zubehör Kabel mit Drähten von 1 mm² Durchmesser verwenden
- Werden keine Lichtschranken verwendet, müssen die Klemmen 1 u. 2 überbrückt werden.
- Wird keine Stop-Taste verwendet, müssen die Klemmen 3 u. 6 überbrückt werden.
- Die Öffnen/Schliessen Betriebszeiten müssen am Trimmer-Schalter höher als des effektiven Torlaufes eingestellt werden.
- NB: Werden Zusätze wie Videokameras, Leuchten etc. angeschlossen, müssen statische Relais verwendet werden, da ansonsten Störungen beim Mikroprozessor auftreten können.

Diagnose-LEDs:

- L An** = Unter 230V oder 400V Versorgungsspannung und Integrität der Sicherungen F1, F2, F3, F4, F5, F6
- L0 An** = Gehtürfunktion, leuchtet bei jeder Gehtür-Impuls-gabe
- L1 An** = Lichtschranke beim Schliessen, kein Hindernis vorhanden
- L4 Aus** = Öffnen, leuchtet bei einer Auf-Impuls-gabe
- L5 Aus** = Schliessen, leuchtet bei einer Zu-Impuls-gabe
- L6 An** = Stop, erlischt bei einer Stop-Impuls-gabe
- L7 Aus** = Funk, erlischt bei jeder Impuls-gabe des Handsenders und Funkkontakt
- L8 An** = Erlischt wenn Fc.C. (Endschalter Schliessung) engagiert ist, M1
- L10 An** = Erlischt wenn Fc.A. (Endschalter Öffnung) engagiert ist, M1
- L33 An** = Schall-leiste zum Schliessung Schutz, kein Hindernis vorhanden
- L34 An** = Schall-leiste oder Lichtschranke zum Öffnung Schutz, kein Hindernis vorhanden

FEHLERSUCHE BEI BETRIEBSSTÖRUNG DER STEUERUNG

- Prüfen Sie die Versorgung an der elektronischen Steuerung, sie muss 230V ± 10% oder 400V ± 10%.
- Prüfen Sie die Versorgung an dem E-Motor, sie muss 230V ± 10% oder 400V ± 10%.
- Kontrollieren Sie die Sicherungen
- Kontrollieren Sie, ob die Lichtschranken einen N.C. Anschluss aufweisen
- Kontrollieren Sie, dass zwischen Steuerung Elpro und E-Motor kein Spannungsabfall vorliegt.
- Alle NC-Kontakte der Steuerung prüfen
- Kontrollieren Sie den korrekten Anschluss und Funktion der Endschalter

Symbole

- NA Kontakt
- NC Kontakt
- Resistiver Kontakt 8,2 kΩ oder NC
- Led AN
- Led AUS
- Anzeigelicht oder Leuchte
- Blinkleuchte

! ACHTUNG: bevor die Elektroanschlüsse auszuführen, sicherstellen dass der Spannungsschalter 230V oder 400V korrekt eingestellt ist.
Im Fall ein Motor mit mechanischer Bremse verwendet oder eine Steuerung ELPRO 10 ersetzt wird muss der Dip-Schalter Nr.12 auf OFF gelassen werden.

Dip-Schalter A

- 1 = ON Lichtschranke stoppt b. Öffnung
- 2 = ON Funk.Kein Umkehr b. Öffnung
- 3 = ON Automatische Schliessung
- 4 = ON Vorblinken aktiv
- 5 = ON Funkkontakt. Schrittweise
- 6 = ON Totmann-Funktion
- 7 = ON Blinkleuchte aus bei der Pause. Automatikbetrieb
- 8 = ON Wiederschliessen während der Öffnung und der Pause wenn die Lichtschranke unterbrochen wird
- 9 = ON DSA Kontrolle der Lichtschranken bevor jedem Betrieb
- 10 = ON Kein Hindernis vorhanden bei der Lichtschranken bevor dem Betrieb
- 11 = frei
- 12 = ON Elektrobremse aktiv

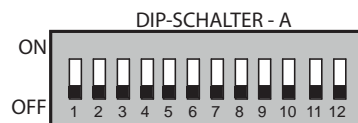

Dip-Schalter B

- 1 = ON Einstellung Bremsungsdauer
- 2 = ON Einstellung der zusätzlichen Stoppzeit nach der Bremsung nach dem Eingriff der Sicherheitsvorrichtungen
- 3 = ON Einstellung Schlosdauer oder Hilfsbeleuchtung
- 4 = OFF frei

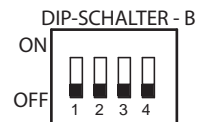







Zubehör	Elektroanschlüsse	Dip-Schalter u. LED-Anzeige der verschiedenen Funktionen
<p>Lichtschranken Öffnung:</p>	<p>Alle NC-Kontakte des Sicherheitszubehörs, wie Lichtschranke (Lichtempfänger), müssen an die Klemmen 1 und 2 in Serie geschaltet werden</p> <p>24Vac Ausgang max. Belastung: 1 Funkempfänger 3 Lichtschranken</p>	<p>DIP-SCHALTER-A Nr. 1:</p> <ul style="list-style-type: none"> ON: sie stoppt während der Öffnung und kehrt bei Schliessung nach Entfernung des Hindernisses um 1 OFF: sie stoppt nicht während der Öffnung und kehrt bei Schliessung bei vorhandenem Hindernis um <ul style="list-style-type: none"> L1 An = kein Hindernis vorhanden; sie erlischt bei vorhandenem Hindernis
<p>Schlüsselschalter:</p>	<p>NO und NC - Kontakte an die entsprechenden Klemmen der Schlüsselschalter oder der Drucktaster anzuschliessen. Die mögliche Konfigurationen sind den jeweiligen Bedienungszubehör beigelegt.</p>	<ul style="list-style-type: none"> L4 Aus = kein Kontakt ÖFFNUNG, sie leuchtet bei jeder Öffnungsimpuls-gabe L5 Aus = kein Kontakt SCHLIESSUNG, sie leuchtet bei jeder Schliessungskontakt L6 An = STOP-Kontakt geschlossen, sie erlischt bei jeder Stop-Impuls-gabe
<p>Funkkontakt (bei schrittweiser Funktion):</p>	<p>Wird jeder beliebige NO Kontakt zwischen der zwei Klemmen angeschlossen, ist folgendes bei jeder Impuls-gabe möglich:</p> <ul style="list-style-type: none"> - Nur Öffnung: Dip 2=ON u. Dip 5=OFF - Richtungsumkehr bei jeder Impuls-gabe Dip 2=OFF u. Dip 5=OFF - Schrittweise: Öffnen-Stop-Schliessen-Stop Dip 2=OFF U. Dip 5=ON <p>- Während der Öffnung wird kein Befehl akzeptiert. Bei der Pause und beim Schliessen bei jeder Impuls-gabe stoppt und kehrt die Lauffrichtung um: Dip 2=ON u. Dip 5=ON</p>	<p>DIP-SCHALTER-A Nr.2 u. Nr.5:</p> <ul style="list-style-type: none"> ON: Kein Umkehr und kein Stop beim Öffnen 2 OFF: Sie stoppt und kehrt immer beim Öffnen um ON: Schrittweise-Funktion mit Zwischenhalten 5 OFF: Sie kehrt den Lauf bei jeder Impuls-gabe um L7 Aus = kein FUNKkontakt, sie leuchtet bei jeder Funkimpuls-gabe
<p>Anzeigelicht Ausgang 24V- max 3W:</p>	<p>Ausgang für ein eventuelles Anzeigelicht 24V max 3W des Automation-Status: Licht An = offenes Tor Licht Aus = geschlossenes Tor Blinken 0,5s (schnell) = Schliessbewegung Blinken 1s (standard) = Öffnungsbewegung</p>	
<p>Endschalter:</p>	<p>WICHTIG: werden die Endschalter <u>nicht verwendet</u>, die Eingänge 8 - 9 - 10 überbrücken. Fc. (=Endschalter) normalerweise geschlossen verwenden</p> <p>Endschalter beim Schliessen Common Endschalter beim Öffnen</p>	<ul style="list-style-type: none"> L8 An = erlischt beim Fc Schliessen L10 An = erlischt beim Fc Öffnen

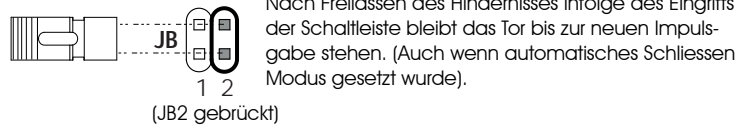
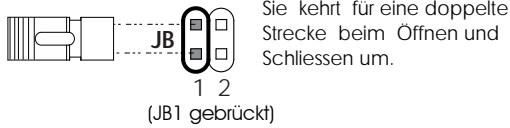
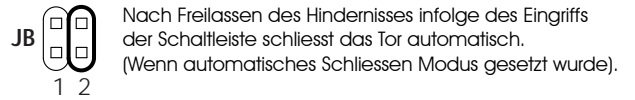
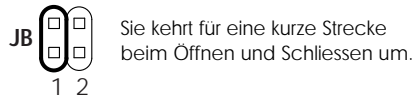

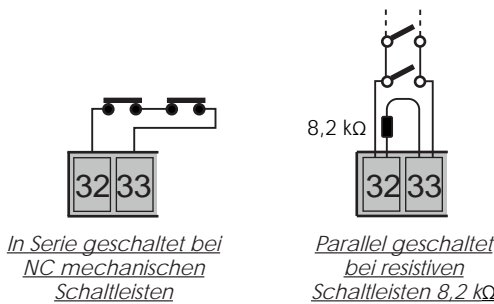
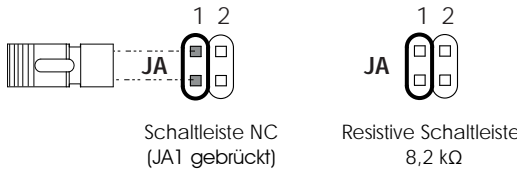

SCHALTLEISTEN

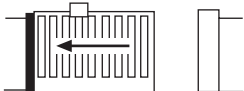
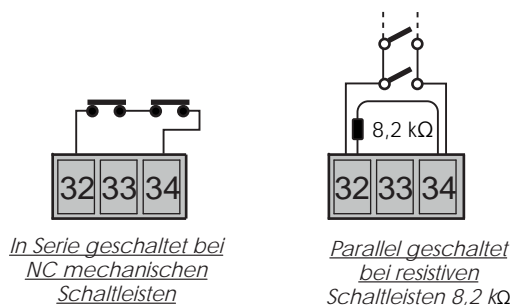
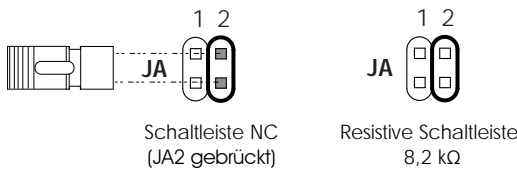
Die zwei Eingänge, vorgesehen zum Anschluß der Schaltleisten, sind für die Öffnungs- und Schließungsphase getrennt. Außerdem kann man die Art des angeschlossenen Kontakts auswählen, entweder mechanisch NC oder resistiv 8,2 k Ω mittels der zwei Überbrückungen JA1 und JA2 (SELECT EDGE TYPE). Dank einer dedizierten Mikrocontroller, auf der Karte eingesteckt, wird die tatsächliche Integrität und perfekte Funktionalität des Sicherheitssystems ständig überwacht. Eventuelle Fehler oder Effizienzverlust werden durch Blinken der L33 und L34 LEDs signalisiert.

Betriebseinsetzung:

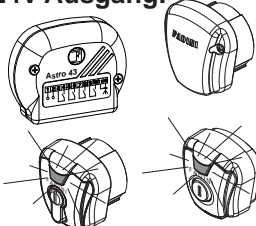
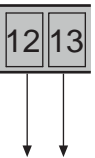
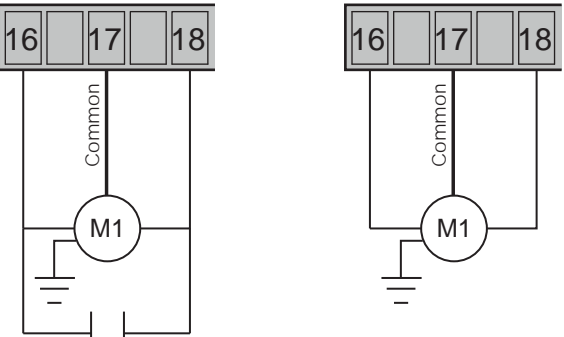

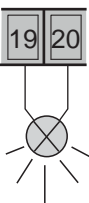
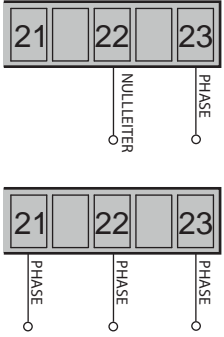
Zubehör	Elektroanschlüsse	LED-Anzeige
<p>Schaltleiste bei der Schließung:</p> 	 <p><i>In Serie geschaltet bei NC mechanischen Schaltleisten</i></p> <p><i>Parallel geschaltet bei resistiven Schaltleisten 8,2 kΩ</i></p> <p>Verwendete Schaltleiste Typ wählen:</p>  <p>Schaltleiste NC (JA1 gebrückt)</p> <p>Resistive Schaltleiste 8,2 kΩ</p>	 <p>Normalerweise an: wenn die Schaltleiste betätigt wird, schaltet die LED aus</p>
<p>Schaltleiste und Lichtschranken bei der Öffnung:</p> 	 <p><i>In Serie geschaltet bei NC mechanischen Schaltleisten</i></p> <p><i>Parallel geschaltet bei resistiven Schaltleisten 8,2 kΩ</i></p> <p>Verwendete Schaltleiste Typ wählen:</p>  <p>Schaltleiste NC (JA2 gebrückt)</p> <p>Resistive Schaltleiste 8,2 kΩ</p>	 <p>Normalerweise an: wenn die Schaltleiste betätigt wird, schaltet die LED aus</p>

Zubehör	Elektroanschlüsse	Dip-Schalter u. LED-Anzeige der verschiedenen Funktionen
<p>24V Ausgang:</p> 	 <p>24Vac AUSGANG für max. Belastung: 3 Lichtschranken 1 Funkempfänger 1 LED Schlüsselschalter Chis 37 / Chis-E 37 Alle Anleitungen sind dem entsprechenden Bedienungszubehör beigelegt</p>	
<p>Ausgang für Motoren:</p> <p>einphasig 230V max 735W - 1,0 PS</p> <p>oder</p> <p>dreiphasig 400V max 1100W - 1,5 PS</p>	 <p>KONDENSATOR EINPHASIGE ELEKTROMOTOREN Versorgung</p> <p>DREIPHASIGE ELEKTROMOTOREN Versorgung</p>	 <p>BETRIEBSZEIT ÖFFNEN-SCHLIEßEN 0s - 120s</p> <p>PAUSEZEIT 1s - 220s</p>
<p>Blinkleuchte 230V:</p> 	 <p>230Vac AUSGANG für Blinkleuchte max 25W</p>	<p>DIP-SCHALTER-A Nr.4 u. Nr.7</p> <p><input checked="" type="checkbox"/> ON: Vorblinken bevor der Bewegung 4 OFF: Ohne Vorblinken</p> <p><input checked="" type="checkbox"/> ON: Blinkleuchte während der Pause ausgeschaltet. Automatischer Betrieb (Dip 3= ON) 7 OFF: Blinkleuchte blinkt während der Pause. Automatischer Betrieb (Dip 3= ON)</p>
<p>230V - 400V Karte Versorgung</p> <p>EINPHASIG oder DREIPHASIG</p>	 <p>EINPHASIGE Karte Versorgung 230V - 50/60Hz ±10%</p> <p>DREIPHASIGE Karte Versorgung 400V - 50/60Hz ±10%</p>	 <p>230V ←</p> <p>→ 400V</p>

Zubehör

Elektroanschlüsse

Dip-Schalter u. LED-Anzeige der verschiedenen Funktionen

**LED Anschluss
Pulin 3:**

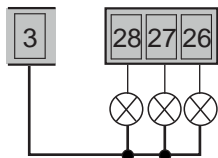
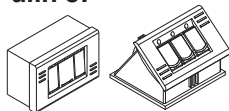

Klemmen zum Anschluss der LED der Drucktastentafel **Pulin 3**

24Vcc-5W Ausgang:



AUSGANG
24Vdc - 5W max

Ampel-Einsteckplatine (Optional - Art-Nr. 7282L):

Die Stromversorgung dieser Platine ist unabhängig von deren der elektronischen Steuerung:
230V 50Hz mit 100W Ausgang zu 230V jede Leuchte.

Betriebslogik:

- GRÜNES Licht = Durchfahrt **OFFEN**
- ROTES Licht = Durchfahrt **GESCHLOSSEN**
- GELBES Licht = Es schaltet ein, bevor das Licht von GRÜN auf ROT schaltet

Anmerkung: Bei **Gehtür**-Modus das Ampellicht ist immer **ROT**.

Dip-Schalter A

- 4 = **ON** Vorblinken eingeschaltet: Ampellicht rot - gelb - grün
- 4 = **OFF** Vorblinken ausgeschaltet: Ampellicht rot - grün

Betrieb mit 2 Leuchten (Rot und Grün):

Dip-Schalter A 4 = **OFF**

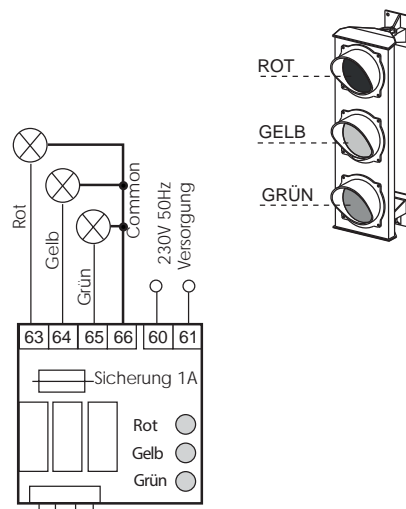

(Optional: Ampel-Einsteckplatine für 230V Leuchten) **Art.Nr. 7282L**

FUNKTIONEN FÜR DIE ÖFFNUNG DES SCHIEBETORS

<p><i>Beschreibung</i></p>	<p><i>Dip-Schalter u. LED-Anzeige der verschiedenen Funktionen</i></p>
<p>AUTOMATISCH / HALBAUTOMATISCH:</p> <p>Automatikzyklus: Das Tor wird auf einen Öffnungsimpuls geöffnet, stoppt während der mit dem Pausen-Trimmer eingestellten Pausenphase und schließt dann wieder automatisch.</p> <p>Halbautomatischer Zyklus: Das Tor wird auf einen Öffnungsimpuls bis zur Endlage geöffnet und dann stoppt. Zum Schließen muss ein entsprechender Schließimpuls erfolgen.</p>	<p>DIP-SCHALTER-A Nr.3:</p> <div style="border: 1px solid black; padding: 5px;"> <p><input type="checkbox"/> ON: Automatisches Schließen</p> <p><input checked="" type="checkbox"/> 3 OFF: Halbautomatische Funktion</p> </div> <p> Trimmer Pause: Einstellung der Pausenzeit im Automatikmodus von 1s bis 220s</p>
<p>GEHTÜRFUNKTION: Bei geschlossenem Tor ein Öffnungsbefehl auf die Kontakte P-P geben, um das Tor für die Fußgänger zu öffnen.</p> <p>(Bei Verwendung der Gehtürfunktion wird es empfohlen Dip-A Nr.3= ON zur automatischen Schließung zu setzen).</p> <p>Nach einem Stromausfall ist die Funktion "Gehtür-Öffnung" für den ersten folgenden Betriebszyklus nicht aktiv.</p>	<p> GEHTÜR-ÖFFNUNG 1s - 45s</p> <p><input checked="" type="radio"/> L0 Aus= Kein Fußgänger-Kontakt, sie leuchtet bei jeder Fußgänger-Impulsgebung</p> <p> FUßGÄNGER ÖFFNUNG</p> <p></p>
<p>WIEDERSCHLIESSEN NACH DER DURCHFART DER LICHTSCHRANKE: <u>beim Öffnen und während der Pausenphase</u> (mit DIP-A Nr.3=ON)</p> <p>Funktion zum automatischen Schließen nach 3 Sek. nach der Durchfahrt der Lichtschanke.</p>	<p>DIP-SCHALTER-A Nr.8:</p> <div style="border: 1px solid black; padding: 5px;"> <p><input type="checkbox"/> ON: Automatisches Wiederschließen nach der Durchfahrt der Lichtschanke nach 3 Sekunden</p> <p><input checked="" type="checkbox"/> 8 OFF: Kein automatisches Wiederschließen nach der Durchfahrt der Lichtschanke</p> </div>
<p>DSA: AUTOMATISCHE KONTROLLE DER LICHTSCHRANKEN</p> <p>Für die DSA-Kontrolle (Device for Safety Auto-test) ist es erforderlich, nur die Lichtsender an diesen Ausgang anzuschließen und Dip-B Nr.9=ON zu setzen. Ist diese Funktion zugeschaltet, wird durch Elpro 37 den einwandfreien Betrieb aller Sicherheitsvorrichtungen vor jeder Torbewegung überprüft, ob kein Hindernis vorhanden ist, sonst wird das Tor nicht geöffnet.</p>	<p> 24V ac Ausgang für Lichtsender TX zur DSA-Kontrolle</p> <p>DIP-SCHALTER-B Nr.9:</p> <div style="border: 1px solid black; padding: 5px;"> <p><input type="checkbox"/> ON: <u>DSA-Kontrolle</u> eingeschaltet</p> <p><input checked="" type="checkbox"/> 9 OFF: <u>DSA-Kontrolle</u> ausgeschaltet</p> </div>
<p>TOTMANN-BEDIENUNG: Öffnung- und Schließungs-Bedienung "durch gehaltene Betätigung" (kein Selbsthalten des Relais), d.h. dass die aktive Anwesenheit des Bedieners während der Automation-Bewegung nötig ist, bis die Taste oder der Schlüssel des Schalters losgelassen wird.</p>	<p>DIP-SCHALTER-B Nr.6:</p> <div style="border: 1px solid black; padding: 5px;"> <p><input type="checkbox"/> ON: Totmann-Bedienung eingeschaltet</p> <p><input checked="" type="checkbox"/> 6 OFF: Totmann-Bedienung ausgeschaltet</p> </div>
<p>PARTY FUNCTION</p> <p>ÖFFNUNG ÜBER EXTERNEN TIMER:</p> <p>Anschluss: NO-Kontakt des Timers mit Klemmen Nr.4 ÖFFNEN und Nr.3 COMMON anschließen und das automatische Schließen mit Dip-Schalter Nr.3=ON freischalten.</p> <p>Funktionsweise: Öffnungsuhrzeit am Timer programmieren und das Tor wird zur eingestellten Uhrzeit geöffnet und bleibt offen (Blinkleuchte geht aus). Bis zum Ablauf der eingestellten Uhrzeit ist das Tor für <u>keine weiteren Befehle</u> (auch Funkbefehl) <u>empfänglich</u>, anschließend wird es nach der Pausenzeit automatisch geschlossen.</p> <p>Während das Tor offen ist, gemäß der auf den "Timer" eingestellten Pausenzeit, stellt das Anzeigelicht zwei aufeinanderfolgenden Blinken aus, von einer langen Pause gefolgt.</p>	<p> Externe Uhr</p> <p>DIP-SCHALTER-A Nr.3:</p> <div style="border: 1px solid black; padding: 5px;"> <p><input type="checkbox"/> ON: Automatisches Schließen</p> <p><input checked="" type="checkbox"/> 3</p> </div> <p>WICHTIG: Verwenden Sie immer nur mit Dip-A Nr.3 = ON</p>

ELEKTROBREMSE FUNKTIONEN

ACHTUNG: Im Fall ein Motor mit mechanischer Bremse verwendet oder eine Steuerung ELPRO 10 ersetzt wird muss der Dip-Schalter Nr.12 auf OFF gelassen werden.

<p>Beschreibung</p> <p>Um die elektronische Bremse einzuschalten, muss der Dip-Schalter - A Nr. 12 auf ON gesetzt werden und die Intensität der elektronischen Bremse über den Schalter in der Abbildung einstellen.</p> <p><u>Die werkseitigen Einstellungen sind geeignet für meistens der Installationen.</u></p> <p>Für die Feineinstellung der elektronischen Bremse können die verschiedenen Bremsung Parameter, wie im nachstehenden Abschnitt "Erweiterten Einstellungen der Elektrobremse" beschrieben, eingestellt werden.</p>	<p>Dip - Schalter und Trimmer der verschiedenen Funktionen</p>
---	---

ERWEITERTE EINSTELLUNGEN DER ELEKTROBREMSE

ACHTUNG: Die Elektrobremse muss durch Dip-Schalter Nr. 12 aktiviert werden

Funktion	Beschreibung	Dip - Schalter und Trimmer der verschiedenen Funktionen						
<p>Bremsungsdauer:</p>	<p>Um die Eingriffsdauer der elektronischen Bremsung einzustellen, den Dip-Schalter B N.1 auf ON setzen und die Bremsungszeit mittels des Trimmers T.FUN einstellen.</p> <p><u>Sobald die Kalibrierung der Bremsungsdauer ausgeführt ist, alle Dip-Schalter B auf OFF setzen.</u></p>	<p>Operationen</p> <table border="1" style="width: 100%;"> <tr> <th style="width: 33%;">I</th> <th style="width: 33%;">II</th> <th style="width: 33%;">III</th> </tr> <tr> <td> </td> <td> <p>T.FUN 0s - 2s</p> </td> <td> </td> </tr> </table>	I	II	III		<p>T.FUN 0s - 2s</p>	
I	II	III						
	<p>T.FUN 0s - 2s</p>							
<p>Zusätzliche Stoppzeit nach der Bremsung an der Sicherheitsvorrichtungen:</p>	<p>Um die zusätzliche Stoppzeit nach der Bremsung einzustellen, den Dip-Schalter B N.2 auf ON setzen und die Stoppzeit mittels des Trimmers T.FUN einstellen.</p> <p><u>Sobald die Kalibrierung der zusätzlichen Stoppzeit ausgeführt ist, alle Dip-Schalter B auf OFF setzen.</u></p> <p>N.B.: Diese Funktion ist aktiv und einstellbar auch bei ausgeschalteter Elektrobremse. Diese Funktion ermöglicht es Ihnen, die Umkehrlaufzeit nach dem Eingriff der Lichtschranken oder der Sicherheitsschaltleisten zu erhöhen, um sichere Umkehrungen mit Lauffrichtungswechsel des Tors, besonders bei den Einphasenmotoren mit großen Trägheit, zu erhalten.</p>	<p>Operationen</p> <table border="1" style="width: 100%;"> <tr> <th style="width: 33%;">I</th> <th style="width: 33%;">II</th> <th style="width: 33%;">III</th> </tr> <tr> <td> </td> <td> <p>T.FUN 0s - 3s</p> </td> <td> </td> </tr> </table>	I	II	III		<p>T.FUN 0s - 3s</p>	
I	II	III						
	<p>T.FUN 0s - 3s</p>							
<p>Elektroschloß:</p> <p>oder Hilfsbeleuchtung:</p>	<p>Um die Betriebszeit des Elektroschlusses oder der Hilfsbeleuchtung, an die Ausgang 14-15 angeschlossen, einzustellen, den Dip-Schalter B N.3 auf ON setzen und die Betriebszeit mittels des Trimmers T.FUN einstellen.</p> <p><i>In diesem Modus ermöglicht der Trimmer T.FUN., in der ersten Hälfte, die Aktivierungszeit von einem Elektroschloß von 0s bis 5s einzustellen. In der zweiten Hälfte ermöglicht der Trimmer ein Relais zur Steuerung der Hilfsbeleuchtung an die Ausgang 14-15 anzuschließen, diese ist von 30s bis 5min einstellbar.</i></p> <p><u>Sobald die Einstellung der Aktivierungszeit des Elektroschlusses oder der Hilfsbeleuchtung ausgeführt ist, alle Dip-Schalter B auf OFF setzen.</u></p> <div style="display: flex; align-items: center;"> <div style="border: 1px solid black; padding: 2px; margin-right: 5px;">14</div> <div style="border: 1px solid black; padding: 2px; margin-right: 5px;">15</div> <div style="margin-left: 10px;"> <p>12Vac Versorgung Ausgang für Elektroschloß 15VA max oder Relais zur Steuerung der Hilfsbeleuchtung</p> </div> </div>	<p>Operationen</p> <table border="1" style="width: 100%;"> <tr> <th style="width: 33%;">I</th> <th style="width: 33%;">II</th> <th style="width: 33%;">III</th> </tr> <tr> <td> </td> <td> <p>T.FUN 5s 30s 0s 5min</p> </td> <td> </td> </tr> </table>	I	II	III		<p>T.FUN 5s 30s 0s 5min</p>	
I	II	III						
	<p>T.FUN 5s 30s 0s 5min</p>							



- I** - Prima dell'installazione da parte di personale tecnico qualificato, si consiglia di prendere visione del Libretto Normative di Sicurezza che la Meccanica Fadini mette a disposizione.
- GB** - Please note that installation must be carried out by qualified technicians following Meccanica Fadini's Safety Norms Manual.
- F** - L'installation doit être effectuée par un technicien qualifié suivant le manuel des Normes de Sécurité de Meccanica Fadini.
- D** - Vor der Installation durch qualifiziertes technisches Personal wird empfohlen das Handbuch zu den Sicherheitsvorschriften durchzulesen, das die Meccanica Fadini zur Verfügung stellt.

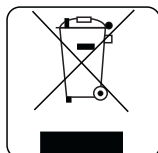

Direttiva **2003/108/CE**
Smaltimento dei materiali
elettrici ed elettronici

**VIETATO GETTARE NEI RIFIUTI
MATERIALI NOCIVI PER L'AMBIENTE**



2003/108/CE Directive
for waste electrical and
electronic equipments

**DISPOSE OF PROPERLY
ENVIRONMENT-NOXIOUS MATERIALS**



**meccanica
FADINI**
s.n.c.

Via Mantova, 177/A - 37053 Cerea (Verona) Italy - Tel. +39 0442 330422 r.a. - Fax +39 0442 331054
e-mail: info@fadini.net - www.fadini.net

La ditta costruttrice si riserva di apportare modifiche al presente libretto senza preavviso