

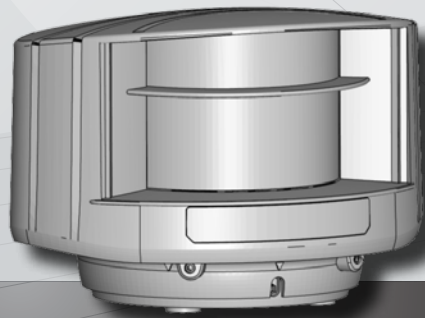

EN



## LZR<sup>®</sup>-H110

LASER SCANNER FOR BARRIERS & GATES

with max. detection range of 5.0 m x 6.5 m

## SAFETY



The device contains IR and visible laser diodes.  
 IR laser: wavelength 905nm; max. output pulse power 75W (Class 1 according to IEC 60825-1)  
 Visible laser: wavelength 650nm; max. output CW power 3mW (Class 3R according to IEC 60825-1)

The visible laser beams are inactive during normal functioning.  
 The installer can activate the visible lasers if needed.



### CAUTION!

Use of controls, adjustments or performance of procedures other than those specified herein may result in hazardous radiation exposure.

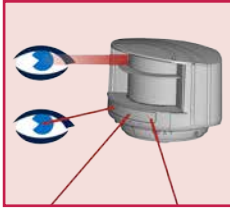

Do not look into the laser emitter or the visible red laser beams.

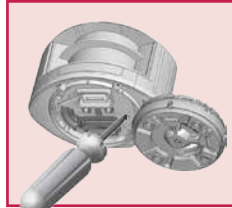

The warranty is void if unauthorized repairs are made or attempted by unauthorized personnel.



Only trained and qualified personnel may install and adjust the sensor.

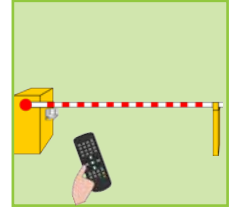

After installation, enter an access code by remote control.

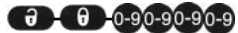

This sensor is designed to be used as a movement and presence detector to control the opening and the closing process of a gate or a barrier. Other use of the device, especially on industrial doors, is outside the permitted purpose and cannot be guaranteed by the manufacturer and might infringe the following patent application EP 1 470 314 B1. The manufacturer of the system is responsible for installing the sensor and the system in compliance with applicable national and international regulations and standards on safety and if applicable, the machinery directive 2006/42/EC. The manufacturer of the sensor cannot be held responsible for incorrect installations or inappropriate adjustments of the sensor.

## INSTALLATION AND MAINTENANCE



Avoid extreme vibrations.



Do not cover the front screens.

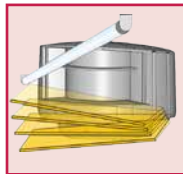

Avoid moving objects and light sources in the detection field.



Avoid the presence of smoke and fog in the detection field.



Avoid condensation.

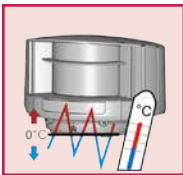

Avoid exposure to sudden and extreme temperature changes.

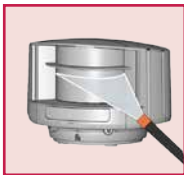

Avoid direct exposure to high pressure cleaning.



Do not use aggressive products to clean the front screens.



Wipe the front screens regularly with a clean and damp cloth.



Keep the sensor permanently powered in environments where the temperature can descend below 0°C.

## DESCRIPTION

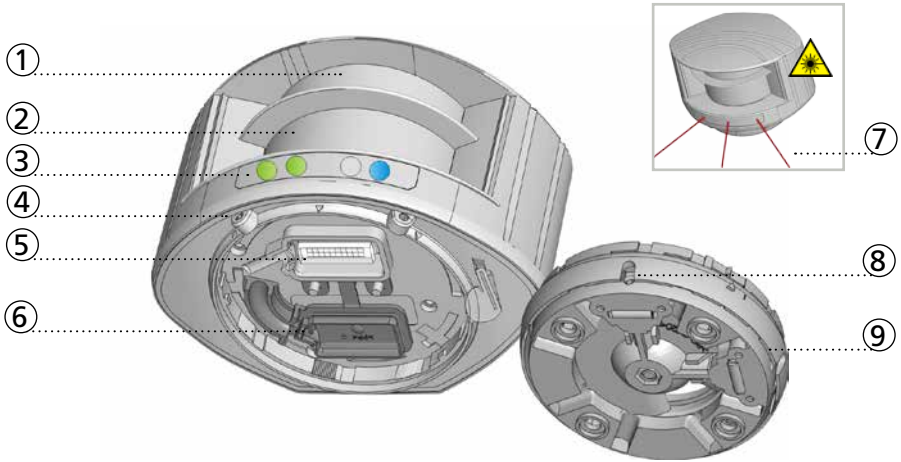

- |                                |  |
|--------------------------------|--|
| 1. laser sweep emission        | 5. connector                           |
| 2. laser sweep reception       | 6. protection cover                    |
| 3. LED-signal (4)              | 7. visible laser beam (3)              |
| 4. screw for position lock (2) | 8. notch for tilt angle adjustment (2) |
|                                | 9. adjustable bracket                  |

## LED-SIGNAL

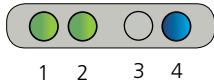

- Detection LED: relay 1 - opening field
- Detection LED: relay 2 - safety field
- Error LED
- Power LED

### DETECTION LEDs

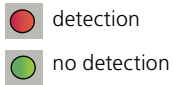

### ERROR LED

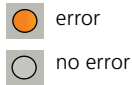

### POWER LED

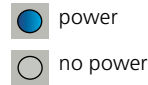

LED flashes quickly



LED flashes



LED flashes slowly



LED is off



All 4 LEDs can be switched off and on again by remote control. This can be useful in cases where the sensor should not draw any attention.



## SYMBOLS



Caution!  
Laser radiation



Remote control  
sequence



Possible remote control  
adjustments



Factory values



Important



Tip



Quick  
installation

## HOW TO USE THE REMOTE CONTROL



After unlocking, the first LED flashes red and the sensor can be adjusted by remote control.



If the red LED flashes quickly after unlocking, you need to enter an access code from 1 to 4 digits.





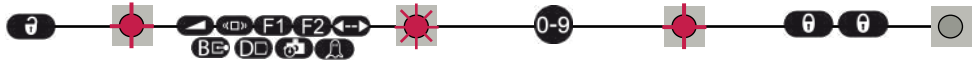

To end an adjustment session, always lock the sensor.

## ADJUSTING ONE OR MORE PARAMETERS

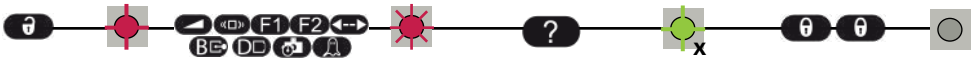

## CHECKING A VALUE



   = field width: 4.2 m  
 = field width is defined by teach-in

## RESTORING TO FACTORY VALUES

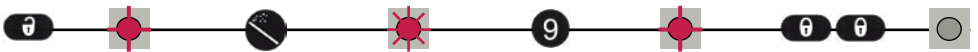

## SAVING AN ACCESS CODE

The access code is recommended for sensors installed close to each other.

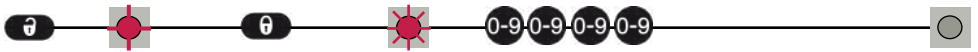

## DELETING AN ACCESS CODE

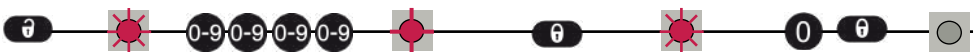

Enter the existing code



X = NUMBER OF FLASHES = VALUE OF THE PARAMETER

# 1 MOUNTING



Keep the front face of the sensor free! Do not cover with glass or plastic.

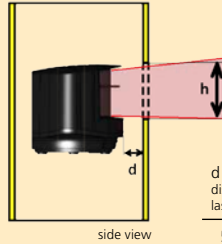
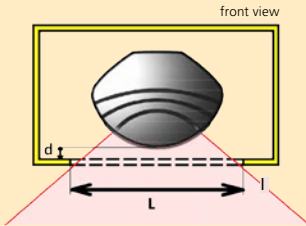

d (mm) distance between laser and opening	$l_{\min}$ (mm)	$h_{\min}$ (mm)
50	240	52
100	360	59
150	480	66
200	600	73

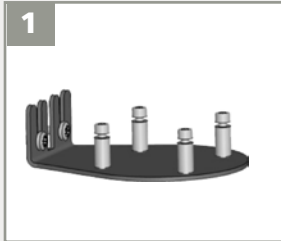

Use the LBA mounting support for installation on the pole.

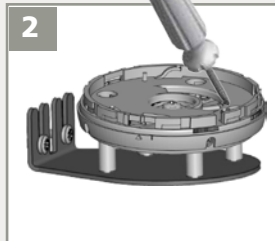

Position the bracket and fasten the 4 screws firmly in order to avoid vibrations.



Open the protection cover, plug the connector and position the cable in the slit.



Close the protection cover and fasten it firmly.

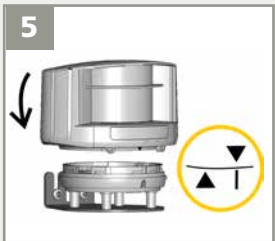

Position the housing on the bracket.



Turn the sensor until the two triangles are face to face.

## 2 WIRING

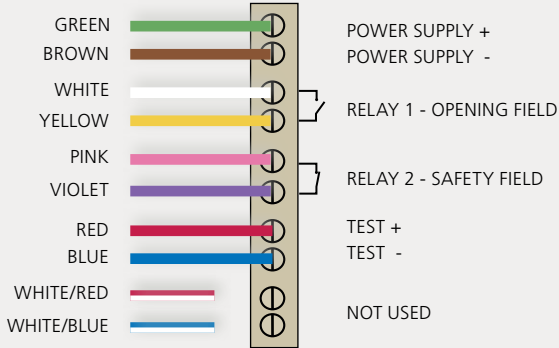

Use the Power Supply Module (24V DC, 0.75 A) if needed.



The sensor tests both relays.



No test function: connect red and blue wires to power supply (no polarity)



Power on with test



No detection



Detection on both relays



## 3 POSITIONING (3 SPOTS)

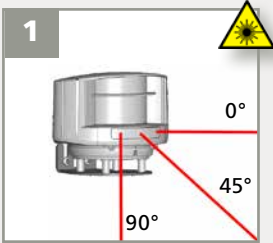

1 Activate the visible laser beams by remote control. To turn off, use same sequence. After 15 minutes the beams switch off.

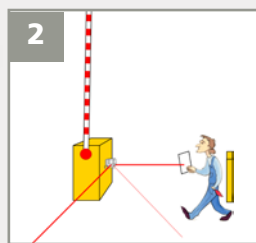

2 Verify the lateral position of the sensor. Make sure the laser beam is visible on the opposite pole.

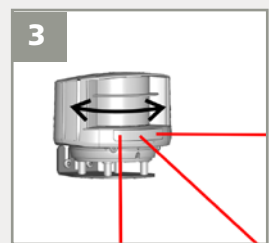

3 If not, turn the sensor slightly on its axis to find the correct position.

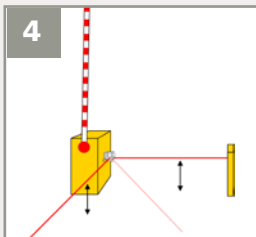

4 Verify if both beams are on equal height.

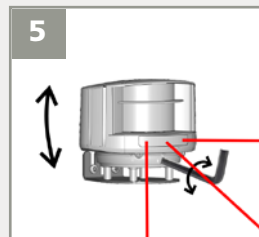

5 Adjust the tilt angle of the detection field with the hex key.



6 Lock the position of the mounting bracket to avoid malfunctioning in case of extreme vibrations.

## 4 MOUNTING SIDE



OR 4

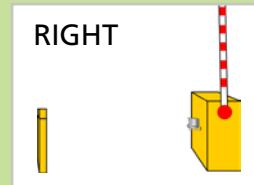
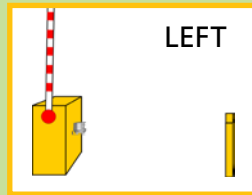

Choose the correct mounting side: LEFT or RIGHT

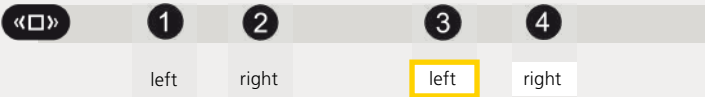

WITH REFERENCE POINT  
(surface of min. 15 cm)

The sensor will automatically adjust  
the safety field on the basis of the  
reference point if  $C = 00$ .

WITHOUT  
REFERENCE POINT

1 LEFT + REF

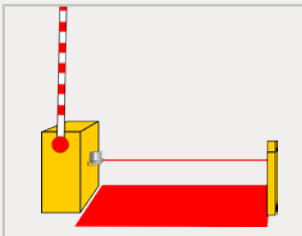

2 RIGHT + REF

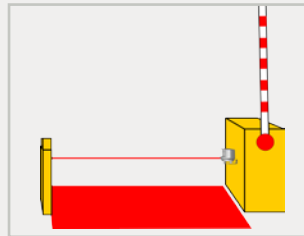

3 LEFT

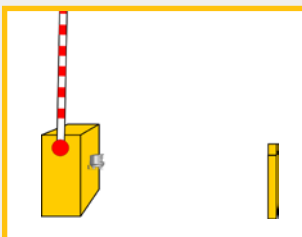

4 RIGHT

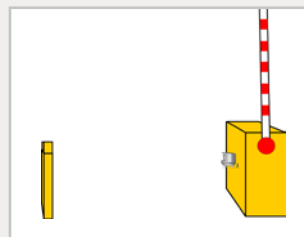

## 5 SAFETY FIELD - PRESENCE

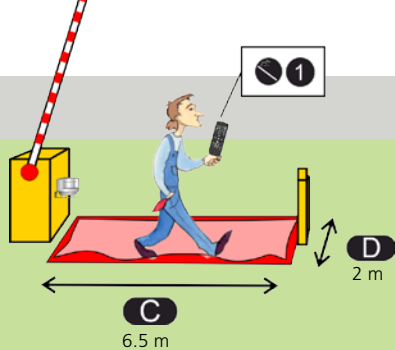
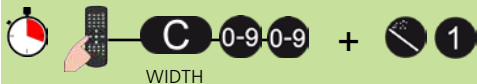

### TEACH-IN

The safety field can be adapted more precisely by launching a teach-in (the sensor learns the environment). Before launching a teach-in, make sure that the selected field size is bigger than the desired field size.



The detection field should be free of snow buildups, heavy rain, snowfall, fog or other moving objects.

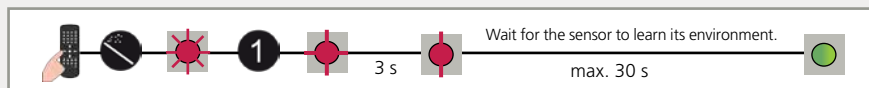

During the teach-in (30 sec.), the sensor takes the reference distances to all objects within its detection zone.

If you walk along the detection area while the teach-in function is active, the sensor memorizes the outline of the walkpath and stores this as a new detection field. The shortest distance measured by each laser beam is stored by the sensor and determines the field limit.

Once the sensor has finished the teach-in, make sure that the safety field is correctly configured and that the area around the barrier or gate is safe.

You can increase or decrease the field by 10 cm:



### FIELD DIMENSIONS

Adjust the field dimensions if you want to get a rectangular field.

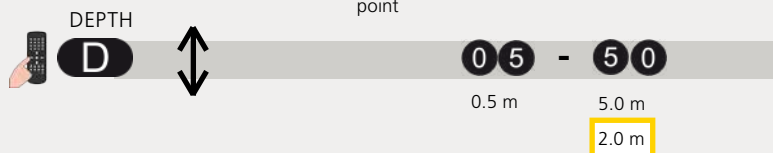
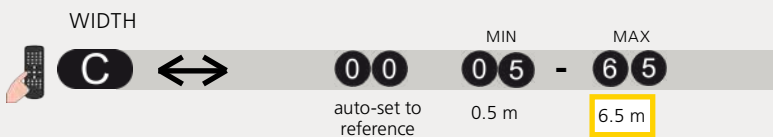

The safety field is necessary for the correct functioning of the installation. If the safety field is too small, the manufacturer of the sensor cannot be held responsible for inappropriate functioning of the installation.



Always launch a new teach-in after adjusting the field dimensions.



## 6 OPENING FIELD - MOTION

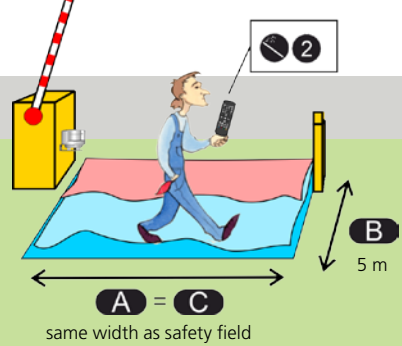

### TEACH-IN

The opening field can be adapted more precisely by launching a teach-in (the sensor learns the environment). Before launching a teach-in, make sure that the selected field size is bigger than the desired field size.



The detection field should be free of snow buildups, heavy rain, snowfall, fog or other moving objects.

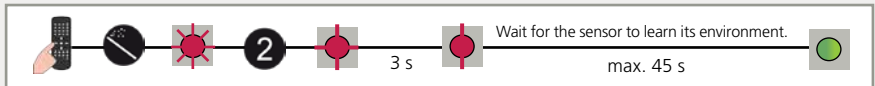

During the teach-in (45 sec.), the sensor takes the reference distances to all objects within its detection zone.

If you walk along the detection area while the teach-in function is active, the sensor memorizes the outline of the walkpath and stores this as a new detection field. The shortest distance measured by each laser beam is stored by the sensor and determines the field limit.

You can increase or decrease the field by 10 cm:



### FIELD DIMENSIONS

Adjust the field dimensions if you want to get a rectangular field.

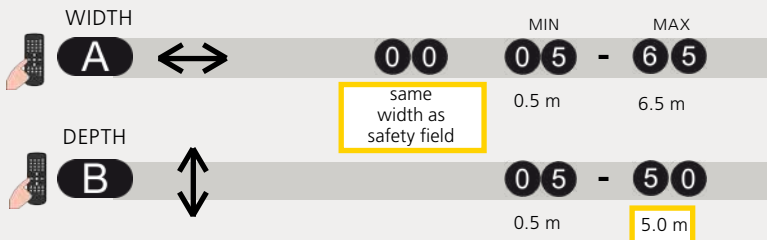

EX: for a field width of 4.5 m

If the 1st red LED (motion) stays ON and no moving objects are in the detection field, reduce the opening impulse field size or launch a new teach-in.

## REMOTE CONTROL ADJUSTMENTS (OPTIONAL)

### MIN. DETECTED OBJECT SIZE

opening field

	1	2	3	4	5	6	
	off	50	65	72	100	120	cm

approximate values

### MAX. PRESENCE TIME

opening field

	0	1	2	3	4	5	6	7	8	9
	off	5 s	10 s	30 s	1 min	2 min	5 min	10 min	2 h	infinite

During detection, the sensor automatically switches from motion to presence detection for a given presence time. Once the object has left the detection field, the presence time is aborted.

### DETECTION TRAJECTORY

opening field

	1	2	3	4	5	6	7	8
--	---	---	---	---	---	---	---	---

	bidirectional detection approaching and going away	BIDIRECTIONAL	1
	unidirectional detection only approaching in any direction	400% CENTER	2
	unidirectional detection only approaching towards the barrier/gate	200% CENTER	3
	unidirectional detection only approaching within width of barrier/gate	100% CENTER	4
	unidirectional detection only approaching towards central zone of barrier/gate	50% CENTER	5
	unidirectional detection only approaching towards centre of barrier/gate	25% CENTER	6
	unidirectional detection only approaching towards right side	100% RIGHT	7
	unidirectional detection only approaching towards left side	100% LEFT	8

## REMOTE CONTROL ADJUSTMENTS (OPTIONAL)

### DETECTION DELAY

opening field

⌚	0	1	2	3	4	5	6	7	8	9
	off	100	200	300	400	500	600	700	800	900 ms

approximate values

### SAFETY FIELD REDIRECTION

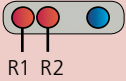

F1	0	1	2
RELAY 1	motion	motion or presence	motion + presence
RELAY 2	presence	presence	presence

### OUTPUT CONFIGURATION

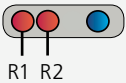

🔌	1	2	3	4
RELAY 1	A - NO	P - NC	P - NC	A - NO
RELAY 2	P - NC	A - NO	P - NC	A - NO

A = active  
P = passive

### IMMUNITY

👤	1	2
	low	high



### MAGIC WAND

🪄	0	1	2	3
		teach-in safety field	teach-in opening field	
🪄	9	🪄		
	factory values	visible laser beams		



FACTORY VALUES

## TROUBLESHOOTING

	No blue LED	There is no power.	<b>1</b> Check cable and connexion.
		The polarity of the power supply is inverted.	<b>1</b> Check the polarity of the power supply.
		All LEDs have been deactivated by remote control.	<b>1</b> Activate the LEDs by remote control.
	The detection LED remains green.	The detection field is too small or deactivated.	<b>1</b> Check the size of the fields. <b>2</b> Launch a teach-in.
		The object size is too small.	<b>1</b> Decrease the min. object size.
	The detection LED remains red.	Someone or something is in the detection field.	<b>1</b> Step out of the field and/or remove the any object(s) from the field.
		The field is touching the floor, the wall or the barrier, which leads to detection.	<b>1</b> Activate the 3 red beams and check if the position of the sensor is correct. If not, adjust the hex screws. <b>2</b> Verify the field size. <b>3</b> Launch a teach-in.
 	The orange LED is flashing and the detection LEDs are red.	No background (reference point) is found.	<b>1</b> Check the position of the sensor. <b>2</b> Check the mounting side setting. If no reference point is found, set the mounting side to value 3 or 4. <b>3</b> Launch a new teach-in.
		The sensor is masked.	<b>1</b> Verify and clean the front screens with a damp cloth.
	The orange LED is on.	The power supply voltage is exceeding the acceptable limits.	<b>1</b> Check the power supply voltage.
		The sensor exceeds its temperature limits.	<b>1</b> Verify the outside temperature where the sensor is installed. Eventually protect the sensor from sunlight using a cover.
		Internal error	<b>1</b> Wait a few seconds. If the LED remains ON, reset the power supply. If the LED turns on again, replace the sensor.
	The sensor does not respond to the remote control.	The batteries in the remote control are not installed properly or dead.	<b>1</b> Verify or replace the batteries.
		The remote control is badly pointed.	<b>1</b> Point the remote control towards the sensor, but with a slight angle. The RC should not be pointed in a right angle in front of the sensor.
		A reflective object is in close proximity to the sensor.	<b>1</b> Avoid highly reflective material in proximity to the sensor.
	The sensor does not unlock.	You have to enter an access code or the wrong code was entered.	<b>1</b> Cut and restore power supply. No code is required to unlock during the first minute after powering.

## TECHNICAL SPECIFICATIONS

Technology:	laser scanner, time-of-flight measurement
Detection mode:	motion and presence
Max. detection range:	5.0 m x 6.5 m
Remission factor:	> 2 %
Angular resolution:	0,3516 °
Emission characteristics	
IR laser:	wavelength 905 nm; max. output pulse power 75 W (CLASS 1)
Red visible laser:	wavelength 650 nm; max. output CW power 3 mW (CLASS 3R)
Supply voltage:	10-35 V DC @ sensor side
Power consumption:	< 5 W
Peak current at power-on:	1.8 A (max. 80 ms @ 35 V)
Cable length:	5 m (standard), max.: 10 m
Response time	
Motion detection:	typ. 200 ms (adjustable)
Presence detection:	typ. 20 ms; max. 80 ms
Output:	2 electronic relays (galvanic isolated - polarity free)
Max. switching voltage:	35 V DC / 24 V AC
Max. switching current:	80 mA (resistive)
Switching time:	t <sub>ON</sub> =5 ms; t <sub>OFF</sub> =5 ms
Output resistance:	typ 30 Ω
Voltage drop on output:	< 0.7 V @ 20 mA
Leakage current:	< 10 µA
Input:	1 optocoupler (galvanic isolated - polarity free)
Max. contact voltage:	30 V DC (over-voltage protected)
Voltage threshold:	Log. H: >8 V DC; Log. L: <3 V DC
LED-signal:	1 blue LED: power-on status 1 orange LED: error status 2 bi-coloured LEDs: detection/output status (green: no detection; red: detection)
Dimensions:	125 mm (D) x 93 mm (W) x 70 mm (H) (with mounting bracket + 14 mm)
Material:	PC/ASA
Colour:	black
Mounting angles on bracket:	-45 °, 0 °, 45 °
Rotation angles on bracket:	-5 ° to +5 ° (lockable)
Tilt angles on bracket:	-3 ° to +3 °
Protection degree:	IP65
Temperature range:	-30 °C to +60 °C if powered; -10 °C to +60 °C unpowered
Humidity:	0-95 % non-condensing
Vibrations:	< 2 G
Pollution on front screens:	max. 30 %; homogenous
Norm conformity:	2006/95/EC: LVD; 2002/95/EC: RoHS; 2004/108/EC: EMC EN 60529:2001; IEC 60825-1:2007; EN 60950-1:2005; EN 61000-6-2:2005; EN 61000-6-3:2006

Specifications are subject to changes without prior notice.  
All values measured in specific conditions.







A DIVISION OF BEA SA | LIEGE SCIENCE PARK | ALLÉE DES NOISETIERS 5 - 4031 ANGLEUR [BELGIUM]  
T +32 4 361 65 89 | F +32 4 361 28 58 | INFO@SENSORIO.BE | WWW.SENSORIO.BE



BEA hereby declares that the LZR®-H110 is in conformity with the basic requirements and the other relevant provisions of the directives 2006/95/EC, 2002/95/EC and 2004/108/EC.

Angleur, July 2014

Pierre Gardier, authorized representative and responsible for technical documentation

The complete declaration of conformity is available on our website: [www.sensorio.be](http://www.sensorio.be)



EC countries: according to the directive 2012/19/EU for Waste Electrical and Electronic Equipment (WEEE)