

Installation & User Manual
For
Styluscom



Wired Video Intercom System

Models StylusAB, StylusABK, StylusAS
Manual Version 1



Contents

Overview of system	Pg 3
Site Survey	Pg 3
SIM card	Pg 3
Power	Pg 3
Installation	Pg 4
Architectural panels	Pg 4
Hooded Panels	Pg 4
Flush Panels	Pg 4
Installing the SIM card	Pg 5
Connections on GSM controller	Pg 5
Codelock Keypad connections	Pg 6
Wiring Tips	Pg 6
Output connections example	Pg 7
Alternative Keypad Wiring	Pg 7
Powering up	Pg 8
Programming	Pg 8
Complete list of Parameters	Pg 11
Keypad Overview	Pg 12
Basic Keypad Programming	Pg 13
Full Keypad Programming	Pg 13
Using the Keypad	Pg 15
Using the Intercom	Pg 15
Control by SMS	Pg 15
Check if Door/Gate Opened/Closed	Pg 16
Using the Optional App	Pg 16
Maintenance of Intercom	Pg 17
Troubleshooting Guide	Pg 17

Overview of System

Please read this entire manual before attempting to install this system.

This system should only be installed by a professional automatic gate installer or access control specialist dealer.

It is recommended that the system be set up, configured, commissioned and tested on a workshop bench **before** taken to site for installation.

Site Survey

If cable has been pre-installed, make sure that the cable type and length is within the guidelines shown below....

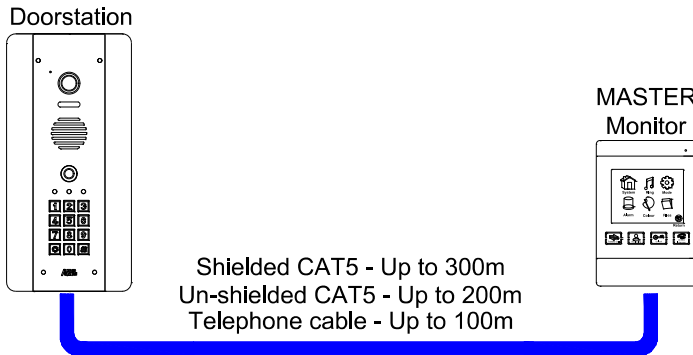

Signal quality will be better with shielded CAT5, and when routed away from power cables.

Power

TIP: Most technical calls received are due to installers using CAT5 or alarm cable to power the unit. Neither are rated to carry enough power over longer distances. Please use following cable...

- Up to 2 metres (6 feet) – Use minimum 0.5mm² (18 gauge)
- Up to 4 metres (12 feet) – Use minimum 0.75mm² (16 gauge)
- Up to 8 metres (24 feet) – Use minimum 1.0mm² (14 gauge)



Using insufficient power cable thickness will cause excessive stress on electronic components, and therefore void the manufacturer's warranty.

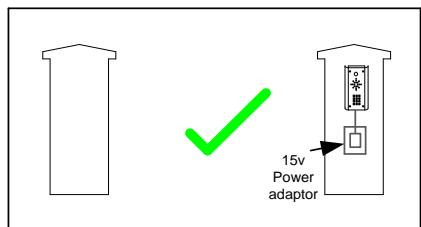
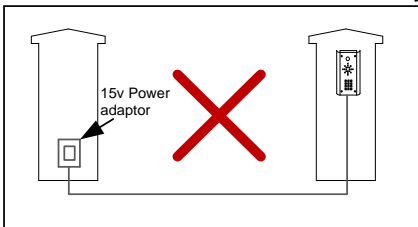

To avoid such problems, it is recommended (and is good practice) to locate power supplies as close to the devices as possible.

Monitor Mounting



1. Mount monitor mounting assembly to wall.

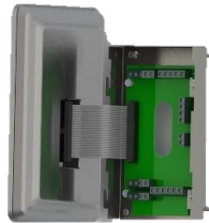

2. Plug monitor into ribbon cable only once all wiring is complete.

Door Station Mounting

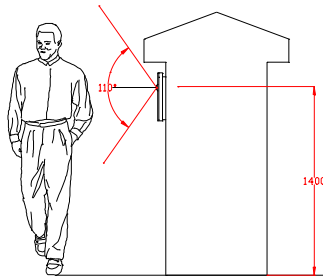

Mount the intercom at the desired height for pedestrian or car users. The camera angle is wide at 110 degrees to cover most scenarios.

Loosen top 2 screws only

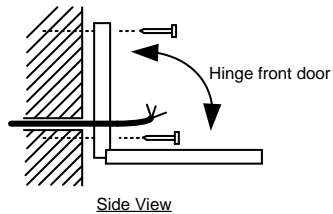
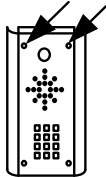

Tip: Do not drill holes in the wall with the intercom in position, otherwise dust may get around the camera window and impair the camera view.

Door Station & Monitor Wiring

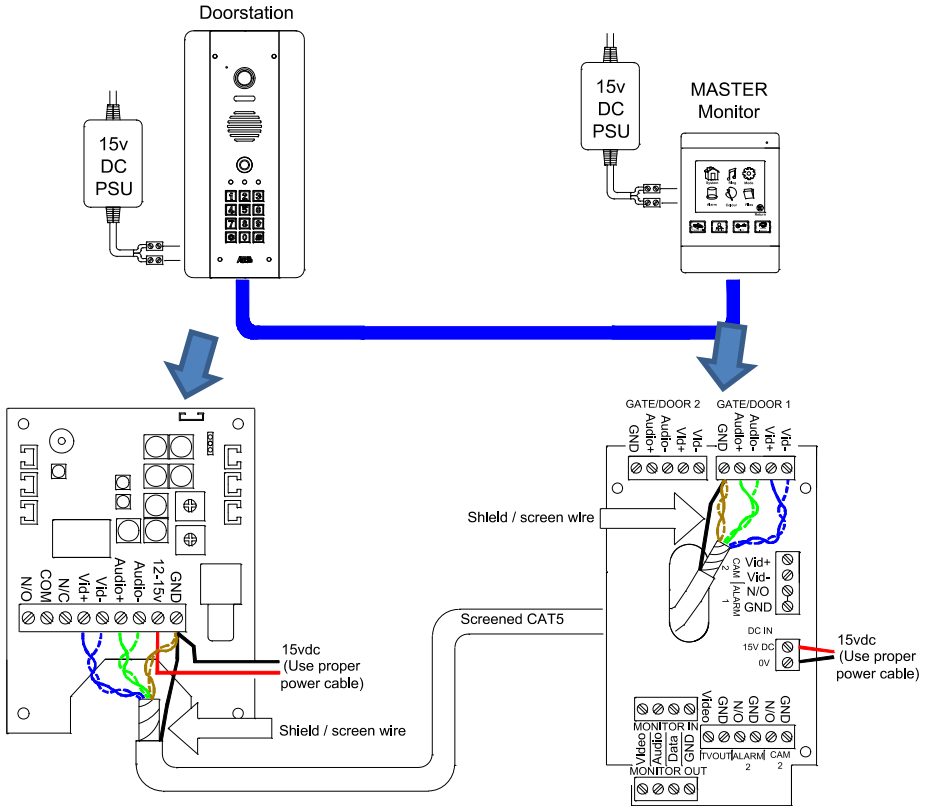

Optional Keypad

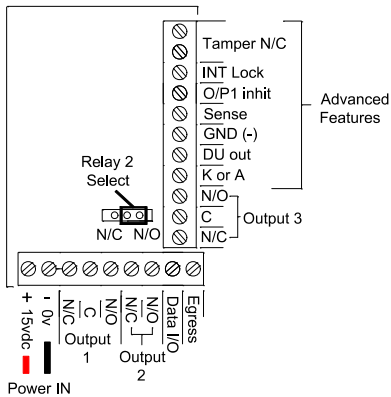

TIP: For using the keypad to control gates wire one or more keypad relays in parallel with the relay on the above intercom module PCB. For locks, wire in series.

Wiring Tips for Locks and Gates

Connection to Automatic Gates

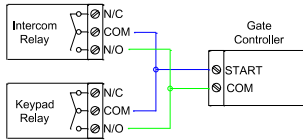

Connection to Door Strike Lock

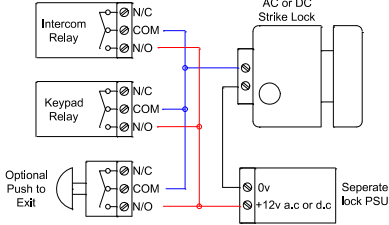

Connection to Magnetic Lock

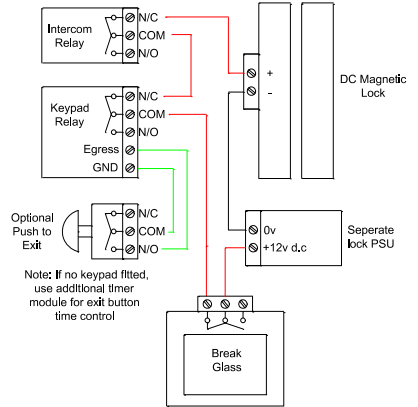

Note: The manufacturer can only support the use, operation and functionality of the intercom and keypad themselves. Professional wiring to door release or automatic gate systems is the responsibility of the installer. Please consult a security integrator for further support.

Basic Keypad Programming

For most installs, it is sufficient to simply enter a single user code as follows..

Quick start guide

1) Enter programming mode (amber LED should be ON)

0 0 0 0 * *

2) Enter a new user code...

1 0 2 0 0 0 ? ? ? ? #

3) Exit programming mode

* *

4) Enter the new user code to check the relay clicks.

Tip: The engineer code must be the same length as user codes. So if using a 6 digit engineer code, then user codes must also be 6 digits long etc.

Full Keypad Programming

Enter programming mode..



The unit is now in programming mode. Amber LED on the keypad should remain permanently on. 0000 is the default programming passcode.

Exit programming mode..



The unit should exit programming mode and the amber LED should start flashing again.

Enter a new ENGINEERS code...

Go into programming mode firstly then enter the following sequence...

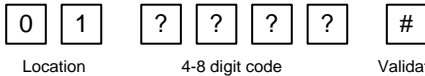

Replace ??? with your new ENGINEERS code.

Location

4-8 digit code

Validate

Enter or delete new user codes

There are 3 groups of user codes. Group 10 for relay 1, group 20 for relay 2, and group 30 for relay 3. The programming sequence is shown below...

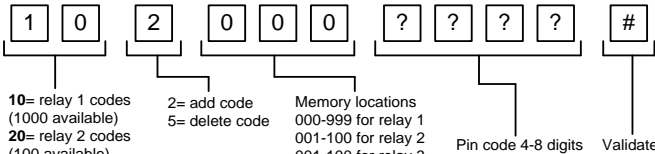

Example: Add user 31 to have access code 5555 operating relay 2....

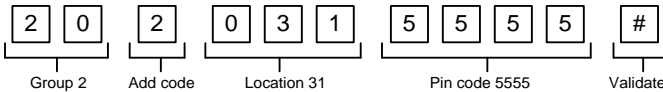

Programming relay output times and modes...

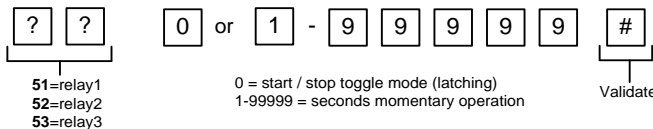

Delete a user code even if you don't know the code...

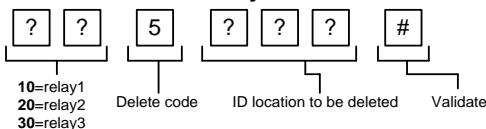

Delete an entire group of codes

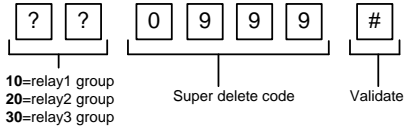

Programming super user codes...

A super user code can activate any of the 3 relays

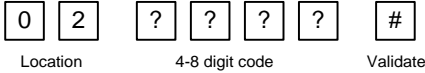

Restoring defaults

When in programming mode, you can enter the following sequence...

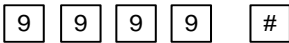

When the master code is forgotten....

- 1) Wire a push button (or replicate with wire link) across the Egress terminal and (-)GND.
- 2) Switch off power for 1 minute.
- 3) Switch ON power.
- 4) During the first 60 seconds, press the EG button once to enable the function.
- 5) Enter the following code..

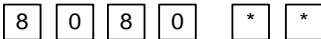

The keypad should now be in programming mode, ready to accept new data.

Using the keypad

Using the standard codes...

Once you have exited out of programming mode, simply enter the user code.

Using super user codes

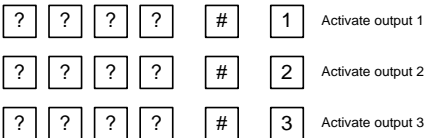

Sound and Volumes

With intercoms operating as a loud speaker and the monitor also acting as a loud speaker, it is important to set up the speech volumes carefully.

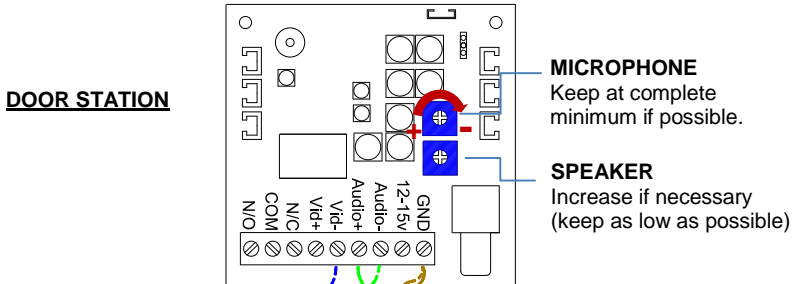

1. Reduce the mic and speaker volumes to minimum levels on the door station and set the indoor monitor volume at approximately 25%.
 2. Keeping the microphone volume at minimum, slowly increase the speaker volume on the door station to a level which is acceptable. Do not increase the speaker volume more than is necessary, otherwise feedback or clipping will occur.
 3. Adjust the monitor speaker volume as necessary, again keeping it as low as possible.
- TIP: Adjusting the microphone sensitivity on the door station is not recommended. For most installs it is best to keep it at the absolute minimum level.

Monitor Power Scheme

Tip: Check distance between monitors before installing wiring. For pre-installed wires, check that the cable type and distance complies with one of the two wiring plans below...

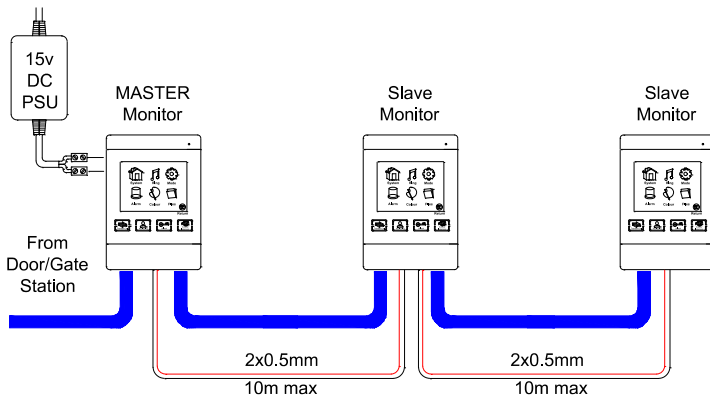

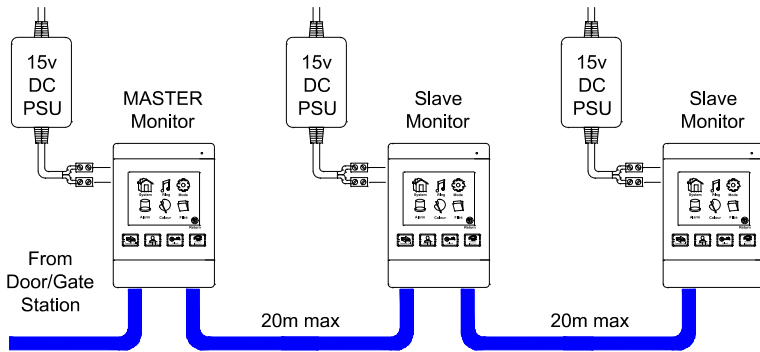

Additional Monitor Wiring

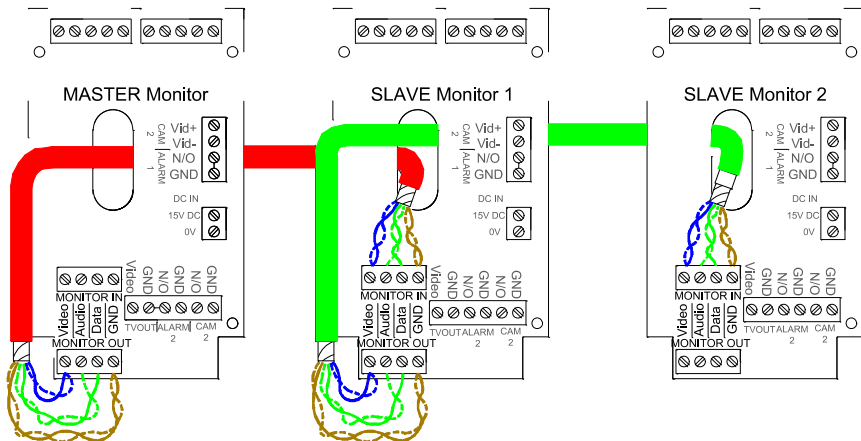

Tip: Up to 4 monitors in total (1 master + 3 slaves) can be used together, depending on cable used and distance between monitors and distance to the door/gate station.

Tip: See next page on how to set MASTER and SLAVE monitor modes.

Monitor Settings

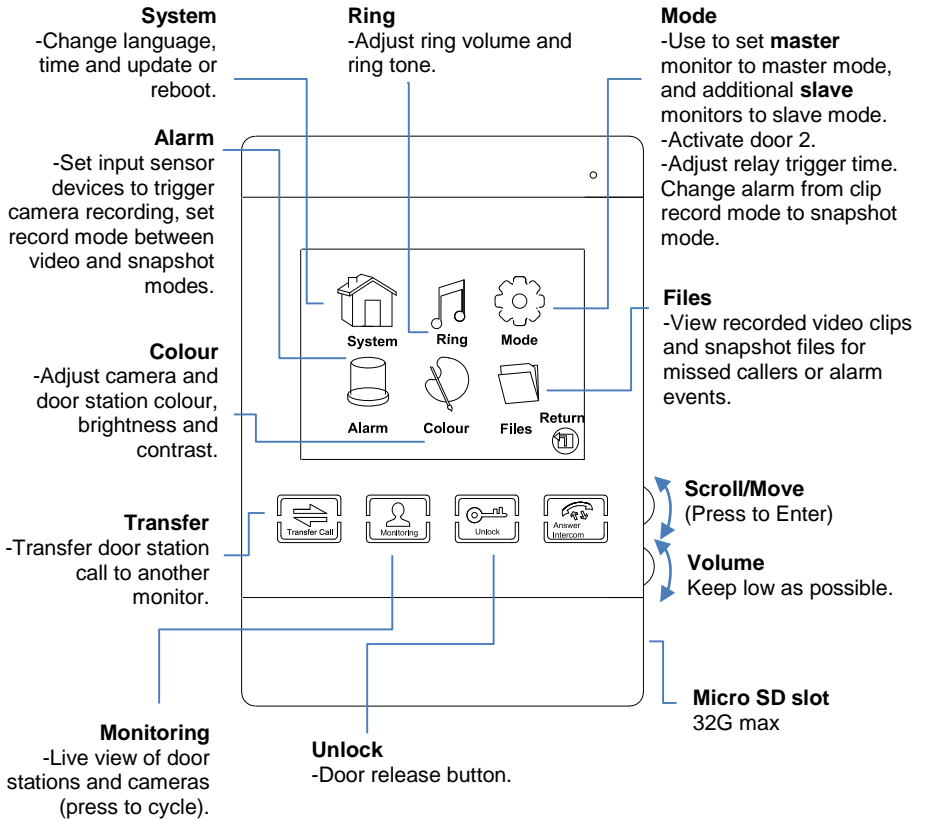

TV Out

This connection can be used to send video (not audio) from the master monitor to a TV, a digital recording system, or modulator for distribution through the TV network (consult a TV/CCTV professional).

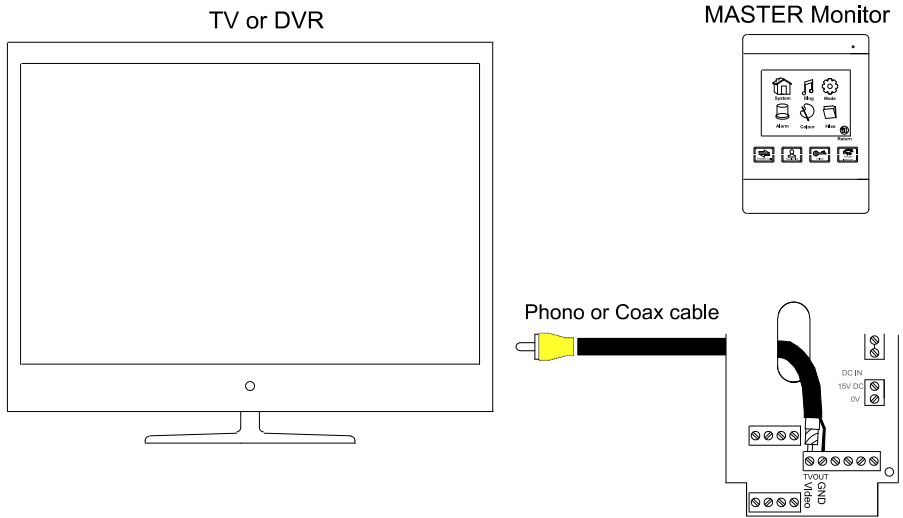

Trouble Shooting

TIP: The best way to troubleshoot any problem is by a process of elimination. Try to install one part of a system at a time, check it works, and then add additional monitors and other items one by one.

Q: I cannot hear the visitor at the gate/door.

A: Check that the cable distance and type between the monitor and gate is within spec.

A: Check that the gate/door station and monitor are powered separately for cable distances of more than 10 metres.

A: Check that the gate/door station microphone sensitivity is at minimum, and the speaker in the gate/door station is turned below 1/3rd volume, and that the monitor speaker volume is at 1/3rd and try again.

A: Check cable cores are not mixed up.

A: Try trimming and re-stripping the cable ends in case of a break. Use a multi-meter on Bell mode to check for breaks.

A: If using additional monitors, try it with only one monitor connected first.

A: Test the gate/door station and the monitor on a test bench or workshop, or inside the house on a shorter cable run (note feedback may prevent sound in one or both direction unless devices are in separate rooms).

Q: I can only hear the visitor faintly, but if I increase the volume on the monitor, I can hear interference and noise.

A: The cable type is not ideal, or too long. Try doubling up cores on the audio wires to see if that helps. If not, you may need to consider upgrading the cable.

Q: Only one monitor is working.

A: Check that the first connected monitor is setup as a MASTER monitor, and that subsequent monitors are configured as SLAVE devices in the onscreen menu.

Q: The intercom is calling, and there is audio, but no video.

A: Check that the cable is proper twisted pair cable, and that it is within spec of this manual. If in doubt, remove either the monitor or gate/door station, and bring to the other side, and test on a few metres of CAT5. If it works, then it is likely the cable is a problem. If it does not work, check wiring connections again and contact technical support.

Q: The video has interference on the picture, or it is not showing colour picture during daytime.

A: This is usually caused by improper cable being used.

A: Check that the monitor and the gate/door station have power supplies connected with proper power cable and within the specified distance in this manual. Poor power cable can cause transmission problems.

A: Upgrade the cable to a shielded CAT5 and connect the shield as shown in the wiring diagram.

Q: The keypad accepts a code, but does not open the gates / door.

A: Check the relay is closing with a multi-meter on bell mode. If the relay changes state, then check wiring and ensure the keypad is connected to the gate system or lock as well as the communication part of the gate/door station (connect in parallel for gates or strike lock, series for magnetic door lock). If the relay does not change state when a code is entered, then the problem is most commonly cause by the keypad not getting enough current draw on the power cable being used. Check the power cable is within spec of this manual.

Change History

Key:

P = Panel version H = Hardware PCB version S = Software version

Version			Reason for change
P	H	S	
1	1	1	First version.
2	1	1	Second gasket for lens spacing.

