

CONTROL PANEL FOR 24V OPERATORS

Z SERIES

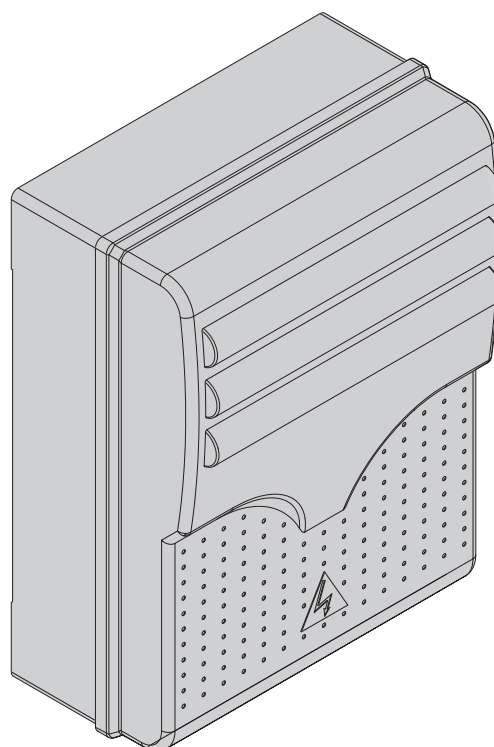

INSTALLATION MANUAL

ZL180

“IMPORTANT INSTALLATION, SAFETY INSTRUCTIONS”

“CAUTION: IMPROPER INSTALLATION MAY CAUSE SERIOUS DAMAGE, FOLLOW ALL INSTALLATION INSTRUCTIONS CAREFULLY”

“THIS MANUAL IS ONLY FOR PROFESSIONAL INSTALLERS OR QUALIFIED PERSONS”



1 Legend of symbols



This symbol indicates sections to be read with particular care.



This symbol indicates sections concerning safety



This symbol indicates notes to communicate to users.

2 Intended use and application

2.1 Intended use

The ZL180 control panel is designed to control the F7024N, A3024N and A5024N swing gate operators.

 The use of this product for purposes other than as described above and installation executed in a manner other than as instructed in this technical manual are prohibited.

2.2 Application

Make sure you respect the distances and cable diameters as shown in “cable types and minimal thicknesses” table.

The overall power of the motors must not exceed 300W.

3 Reference Standards

For its quality processes management Came Cancelli Automatici is ISO 9001:2000 certified, and for its environmental management it is ISO 14001 certified. Came designs and manufactures entirely in Italy.

This product complies with the following standards: *see chapter 12 - Conformity declaration - pag. 13.*

4 Description

This product is engineered and manufactured by CAME cancelli automatici s.p.a. and complies with current safety regulations. Guaranteed 24 months if not tampered with.

The control panel works on 230V a.c. of power, through the terminals L-N, 50/60Hz frequency.

Both command and control devices and accessories are 24V powered.

Warning! Accessories must not exceed 34 W overall.

The control unit is fitted with an amperometric device which constantly regulates the motor's drive coefficient.

When the gate runs into an obstacle, the amperometric sensor immediately detects an overcharge in the drive and redirects the gate's direction of movement, and:

opens it if it is closing⁽¹⁾;

closes it if it is opening.

⁽¹⁾ Warning!: in this case, after 3 consecutive obstacle detections, the gate will stop open excluding the automatic closing function; for movement to start again press the command button or use the remote control.

All connections are protected by quick fuses, see table.

The card provides and controls the following functions:

- automatic closing after an open-command;
- pre-flashing by the motion indicator;
- obstacle detection when gate is still in any position;
- continual monitoring of photocell operation.

The following command modes are possible:

- open/close;
- open/close and maintained action;
- partially open;
- complete stop.

After detecting an obstacle, the photocells will:

- reopen the gate if it is closing;
- partially stop it if it is opening.

Apposite trimmers regulate:

- the automatic closing run time;
- the second gate leaf's motion time difference;
- the amperometric device's detection sensitivity, in separately in terms of normal opening and closing and braking.

TECHNICAL FEATURES

Power supply	230V - 50/60Hz
max. rated power	300W
Power draw when idling	85mA
Max power of 24V accessories	34W
Insulation rating	II
Material	ABS
Protection rating	IP54
operating temperature	-20 / +55°C

FUSES

protection	fuse type
Motor/s	5A-F
Electronic board (power supply line)	1A-F
Accessories	1.6A-F
Control devices	630mA-F

4.1 Dimensions, spans and anchoring holes

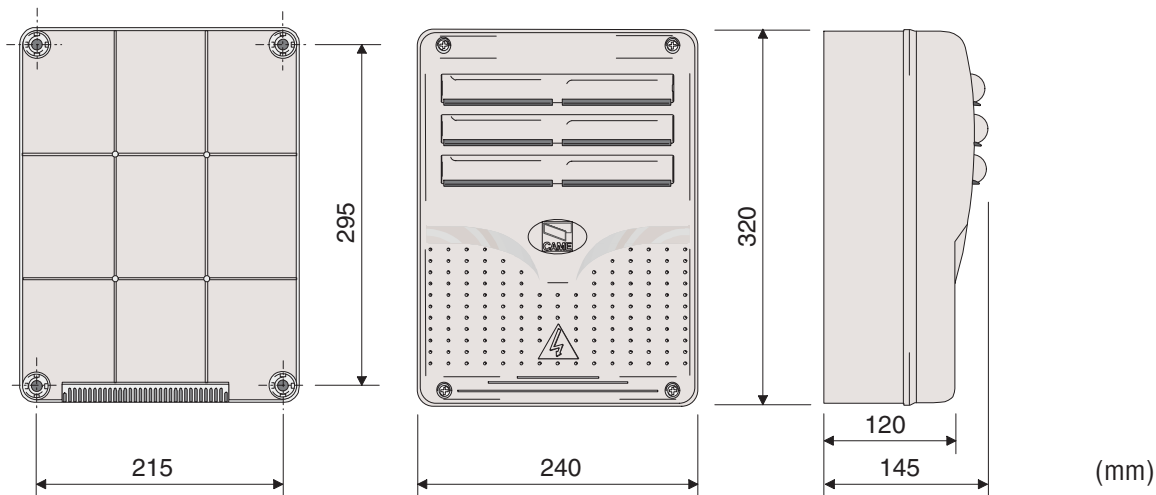

4.2 Main components

- 1 - Transformer
- 2 - Control unit fuse
- 3 - Trimmers (see page 9)
- 4 - Buttons for memorising the radio code
- 5 - Plug for the remote control frequency card
- 6 - Terminal board for connecting the antenna
- 7 - Terminal board for connecting accessories and control devices
- 8 - Terminal board for connecting the gear-motors
- 9 - Terminal board for 230V a.c. power grid
- 10 - Line fuse
- 11 - M1 motor fuse
- 12 - M2 motor fuse
- 13 - Accessories fuse
- 14 - Functions selector
- 15 - Control and signalling LED unit

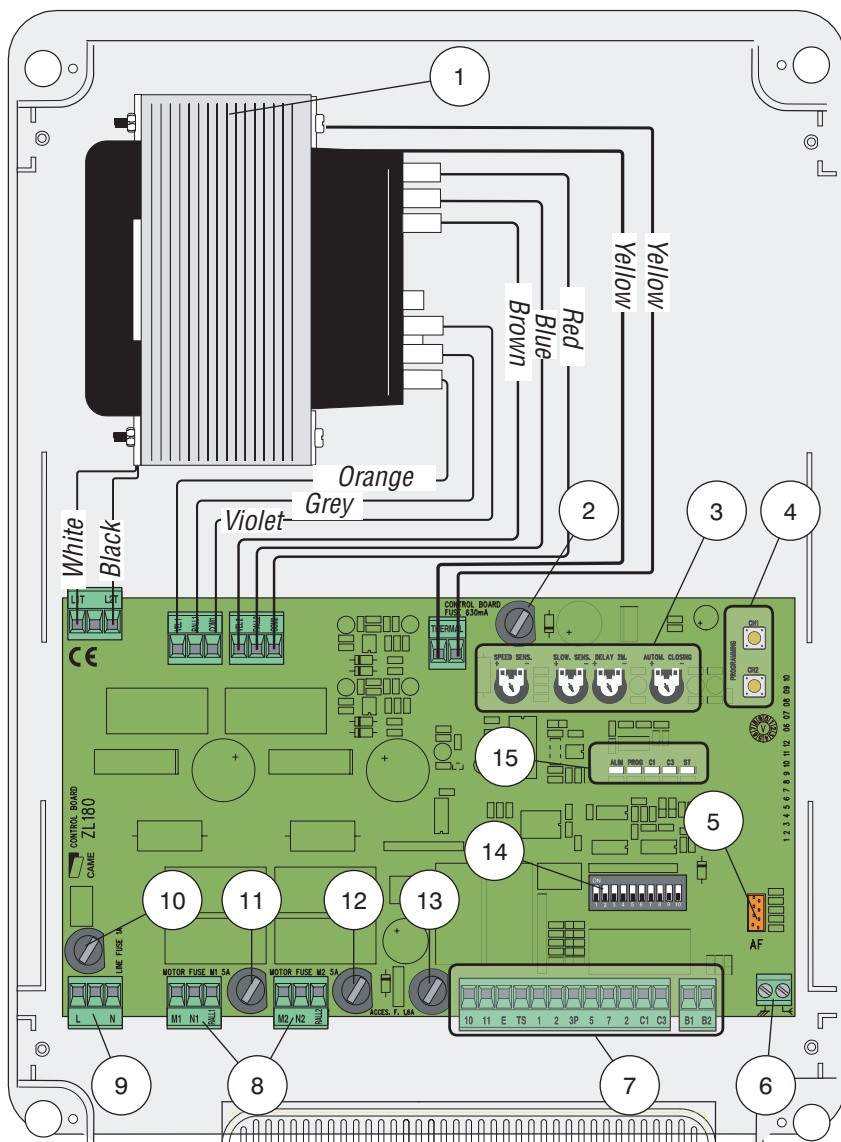

Warning! Before acting on the machinery, cut off the main power supply and disconnect any emergency batteries.

The data and information in this catalogue may change without prior notice from CAME cancelli automatici s.p.a.

5 Installation

5.1 Preliminary checks

 Before installing do the following:

- Check that the panel's anchoring point is protected from possible blows, and that the anchoring surface is solid. Also check that the anchoring is done using the appropriate bolts, screws etc.
- Make sure you have a suitable omnipolar cut-off device with contacts more than 3 mm apart, and independent (sectioned off) power supply.
-  Make sure that any connections inside the case (that provide continuance to the protective circuit) are fitted with extra insulation as compared to the other conductive parts inside;
- Make sure you have suitable tubing and conduits for the electrical cables to pass through and be protected against mechanical damage.

5.2 Tools and materials

Make sure you have all the tools and materials you will need for the installation at hand to work in total safety and compliance with the current standards and regulations. The following figure illustrates the minimum equipment needed by the installer.

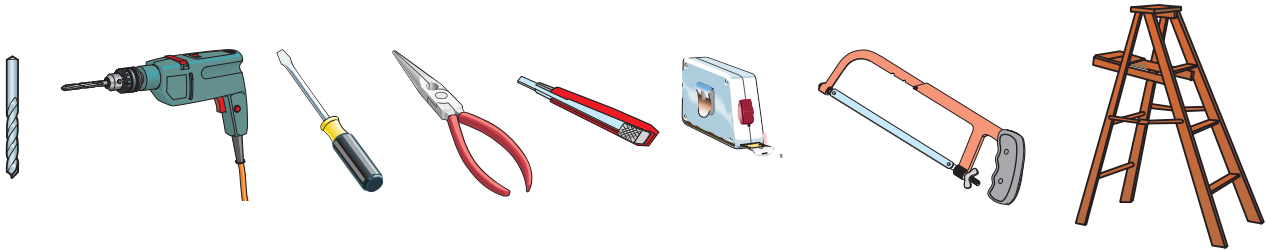

5.3 Fixing and mounting the box

Fix the base of the panel in a protected area; we suggest using round top Phillips recessed head screws of max. 6mm in diameter.

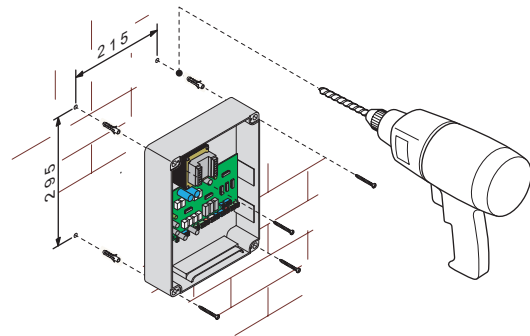

Perforate the pre-punched holes and insert the cable glands with the corrugated tubing for the electrical cables to travel through

N.B.: the pre-punched holes have the following diameters: 23mm 29 and 37 mm.

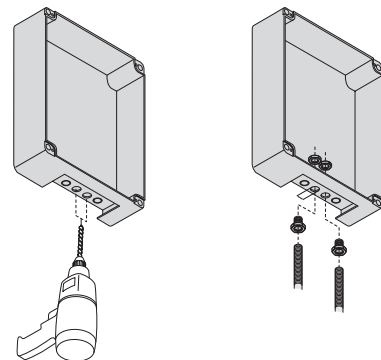

Assemble the pressure hinges.

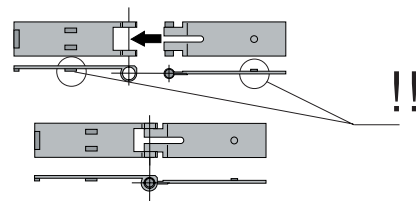

Insert the pressure hinges into the box (on the left or right as you wish) and set them using the provided screws and washers

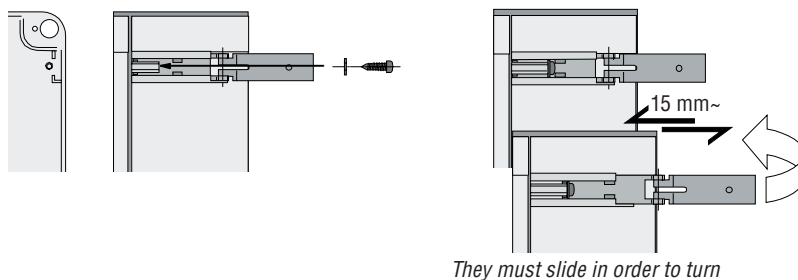

Snap the cover into place onto the hinges. Close it and fix it using the provided screws

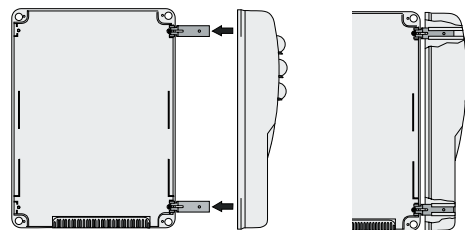

After the adjustments and settings, fix the cover using the provided screws.

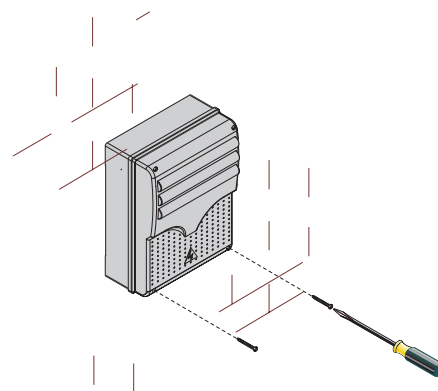

6 Electrical connections

6.1 Cable list and minimum thicknesses

Connections	Type of cable	Length of cable 1 < 10 m	Length of cable 10 < 20 m	Length of cable 20 < 30 m
Control panel power supply 230V	FROR CEI 20-22 CEI EN 50267-2-1	3G x 1,5 mm ²	3G x 2,5 mm ²	3G x 4 mm ²
Motor power supply 24V		2 x 1 mm ²	2 x 1,5 mm ²	2 x 2,5 mm ²
flashing lamp		2 x 0,5 mm ²	2 x 1 mm ²	2 x 1,5 mm ²
Transmitter photocells		2 x 0,5 mm ²	2 x 0,5 mm ²	2 x 0,5 mm ²
Receiver photocells		4 x 0,5 mm ²	4 x 0,5 mm ²	4 x 0,5 mm ²
Power supply to accessories		2 x 0,5 mm ²	2 x 0,5 mm ²	2 x 1 mm ²
Control and safety devices		2 x 0,5 mm ²	2 x 0,5 mm ²	2 x 0,5 mm ²
Antenna connection	RG58	max. 10 m		

N.B.: If the cable length differs from that specified in the table, then you must determine the proper cable diameter based on the actual power draw from the connected devices and according to the CEI EN 60204-1 standards.

For connections that require several, sequential loads, the sizes given on the table must be re-evaluated based on actual power draw and distances.

When connecting products that are not specified in this manual, please follow the documentation provided with said products.

Gearmotor

Closing-speed reduction microswitch

24V d.c. gearmotor featuring delayed action on opening

24V d.c. gearmotor featuring delayed action on closing

Opening-speed blocker microswitch

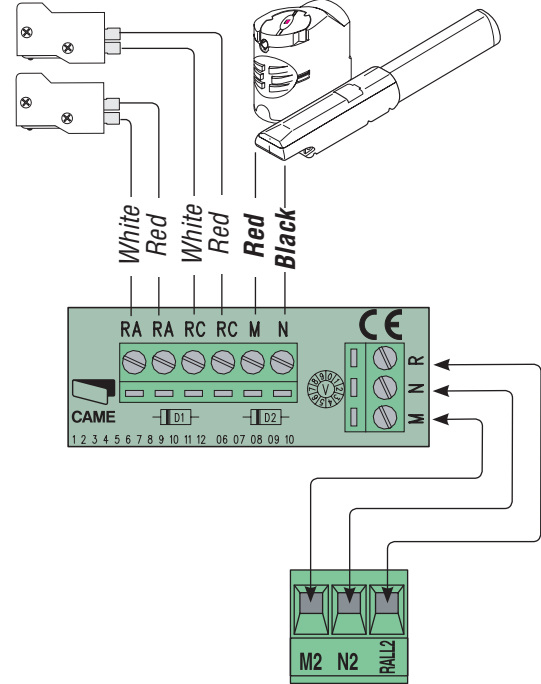
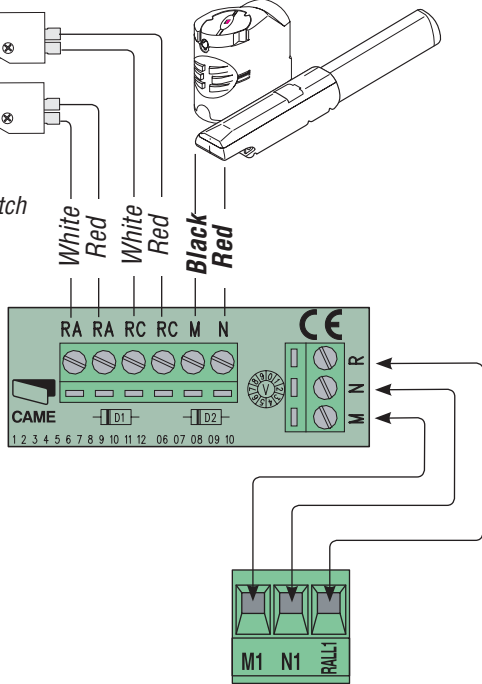

Power supply to accessories

Terminals for powering the following accessories:

- 24V a.c. (normally alternated power)
- 24V a.c. (continuous power) when the emergency batteries are in operation.

Overall power allowed: 34W

Power supply

230V (a.c.) 50/60 Hz

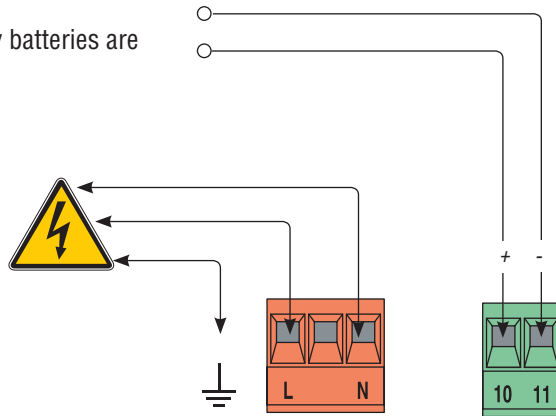

Signalling and Lighting devices

Signal Flasher (socket rating: 24V - 25W max.)

Flashes during opening and closing phases



Open gate indicator-light (socket rating: 24V - 3W max.).

Turns on when the gate is ajar or open.

It turns off when the gate is closed.

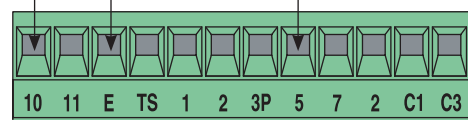

Safety devices

“partial stop” (N.C.) socket

- input for safety devices such as photocells, sensitive edges and other EN 12978-compliant devices. Halts moving gate leaves and causes them to automatically close

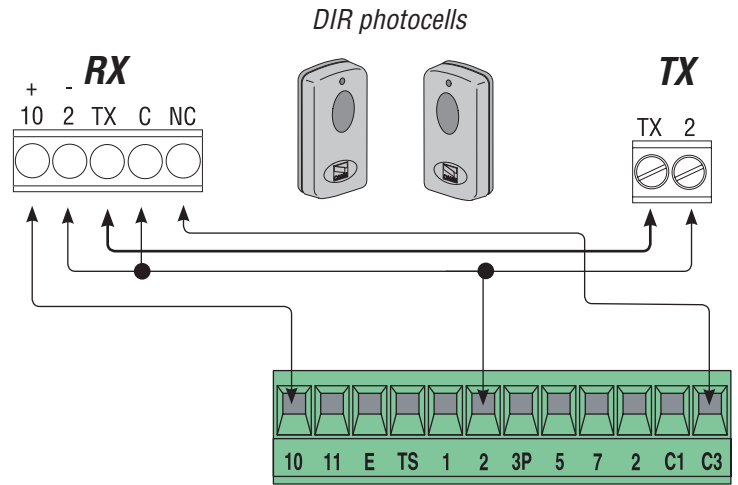

“Open during closing” (N.C.) socket

- Input for safety devices such as photocells, sensitive edges and other EN 12978 compliant devices. When gate leaves are closing, opening the contact causes reversal until total opening is obtained.

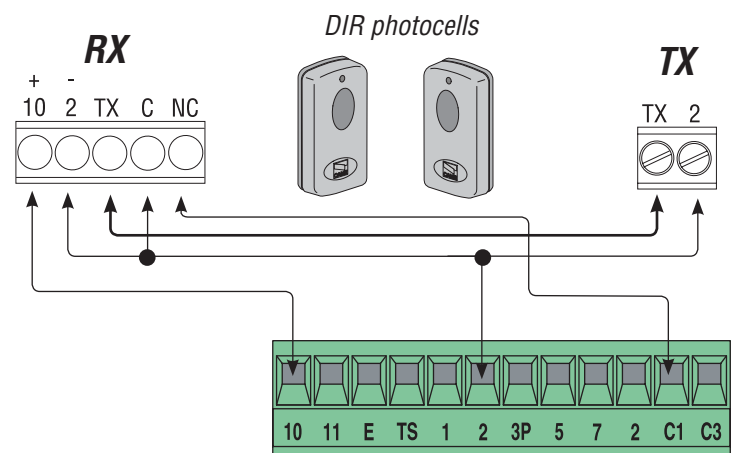

“Partial Stop” (N.C.) socket

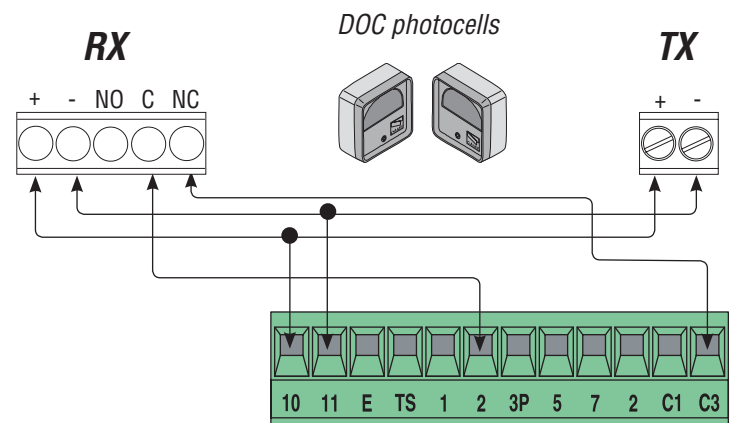

“Open during closing” (N.C.) socket

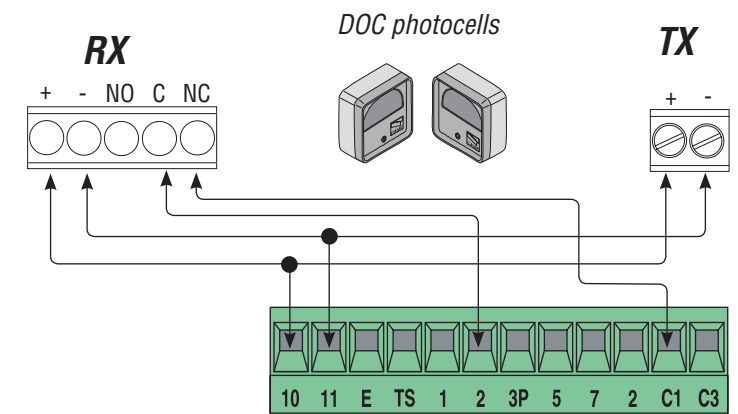

Command devices

Pulsante Stop button (N.C. socket)

- PulsanteButton to stop gate while excluding the automatic closing cycle. For movement to resume you must press the command button or transmitter button.

Key selector and/or partial opening button (N.O. socket)

- Opening of one gate leaf to allow pedestrian passage.

Key selector and/or commands button (N.O. contact)

- Gate closing and opening contacts, by pressing the button or turning the selector key, the gate movement is inverted or halted depending on which selection was just made. (see selecting functions, dips 2 and 3).

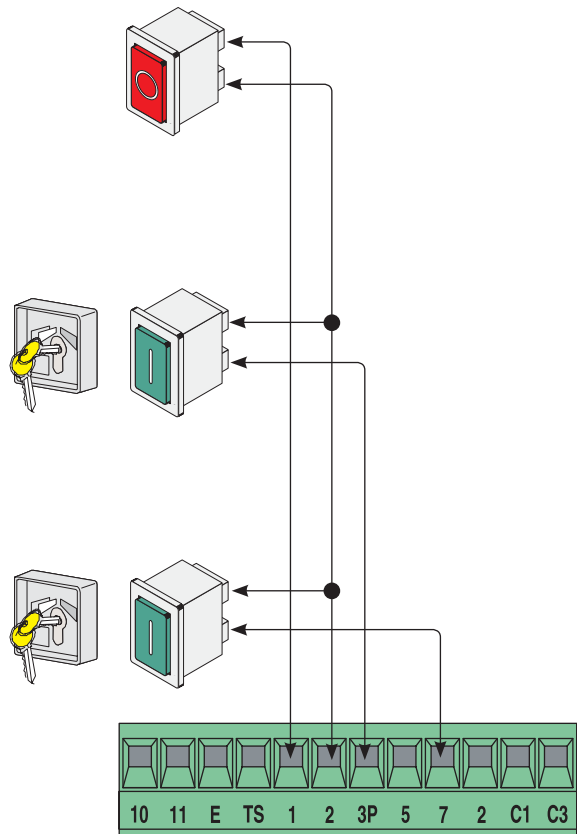

6.2 Electrical connection for the photocells functions test

(DOC)

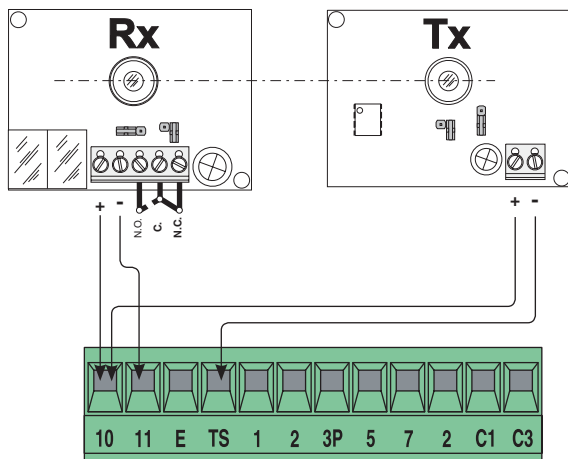

(DIR)

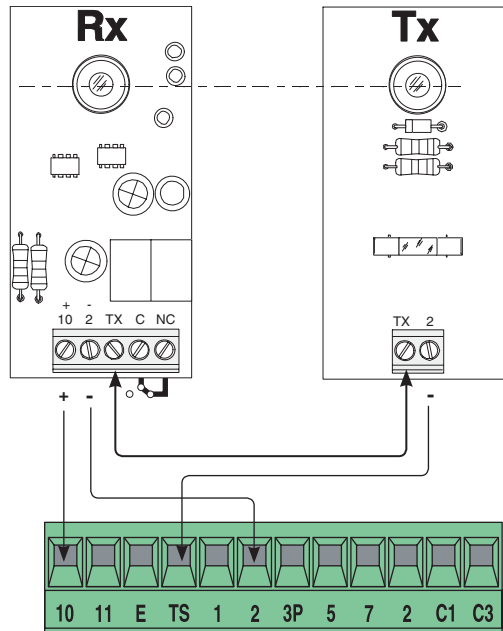

At each opening and closing command, the control board assesses the efficiency status of the control devices (photocells). Any anomaly found is signalled with the flashing of the (PROG) LED on the control panel. Consequently it cancels any commands coming from the remote control or the button.

Electrical connection to enable the photocell safety test:

- the transmitter and the receiver, must be connected as per the diagram;
- set DIP switch 9 to ON to activate test operation.

IMPORTANT:

when running the safety test function, the N.C. contacts, if unused, should be excluded on the relative DIP switches (see chapter 7 "selecting functions").

7 Selecting functions

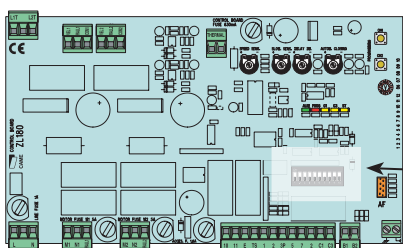

DIP-SWITCH

Default setting



- 1 ON - **Automatic closing** - the automatic closing timer is activated when on opening the gate leaf has reached the full open stroke. The time is preset and adjustable, and is subject to the action of any safety devices. It does not activate after a total safety “stop” or during a power outage;
- 2 ON - **“Open-stop-close-stop”** function with button [2-7] and remote control (with built-in radiofrequency card);
- 2 OFF - **“Open-close”** function with button [2-7] and remote control (with built-in radiofrequency card);
- 3 ON - **“Open only”** function with remote control (featuring built-in radiofrequency card);
- 4 ON - **Pre-Flashing during opening and closing** - Following an opening or closing command, the flasher connected to [10-E], flashes for 5 seconds before initiating the operation;
- 5 ON - **Obstacle detection** - When motor is idle (gate closed, open or after a total stop command), it prevents any motion if the safety devices (e.g. photocells) detect any obstacle;
- 6 ON - **Maintained action** - the gate works by keeping the button pressed (one button [2-3P] for opening, and one button [2-7] for closing);
- 7 OFF - **Reopening during closing** - if the photocells detect an obstacle during gate closing, the gate motion is inverted until total opening is reached; connect the safety device to terminals [2-C1]; sif not used, set DIP switch to ON;
- 8 OFF - **Partial stop** – stops gate when an obstacle is detected by the safety devices; once the obstacle is cleared, the gate remains still or closes if the automatic closing function is enabled. Connect the safety devices to terminal [2-C3]; sif not used, set DIP switch to ON.
- 9 ON - **Operation of the photocells safety test** - this allows the card to assess the efficiency of the safety devices (photocells) after each opening and closing command;
- 10 OFF - **Reaction time** – Increases to 2” the running time of the movement inversion function, controlled by the amperometric sensor.

8 Adjustments

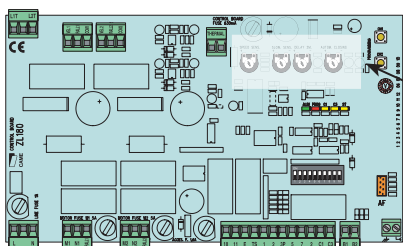

SPEED SENS.



SLOW. SENS. DELAY 2M.



AUTOM. CLOSING

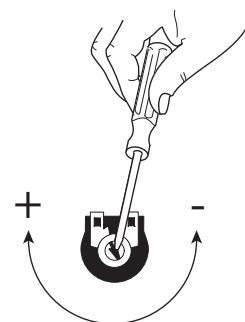

- «**SPEED SENS.**» Adjusts the amperometric sensitivity which controls the power developed by the motor during motion; if the power exceeds the adjusted level, the system sets in motion to invert the direction of motion.
- «**SLOW.SENS.**» Adjusts the amperometric sensitivity which controls the power developed by the motor during slowing downs; if the power exceeds the adjusted level, the system sets in motion to invert the direction of motion.
- «**DELAY 2M**» Adjusts the waiting time of the second motor during each closing run. The waiting time can be adjusted anywhere between 1 and 17 seconds.
- «**AUTOM. CLOSING**» Adjusts the waiting time when gate is open. Once this time has elapsed, the gate closes automatically. The waiting time can be adjusted anywhere between 1 and 150 seconds.

9 Signal LED

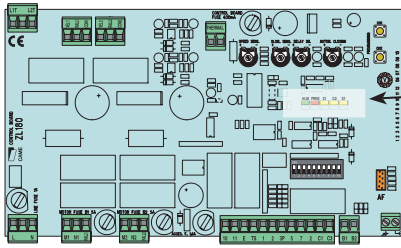

LIST OF CONTROL LED SIGNALS OF THE COMMAND AND SAFETY DEVICES:

- «**ALIM**» Green LED. Normally on, because it signals the cards proper power rate.
- «**PROG**» Red LED. Normally off.
During the remote control's activation procedure, it turns on and blinks.
It blinks faster when combined with LEDs C1/C3/ST
- «**C1**» Yellow LED. Normally off.
When it is on and with the PROG LED blinking it warns of objects detected by the photocells (connected to REOPEN DURING CLOSING) or non-operation of the same.
- «**C3**» Yellow LED. Normally off.
When it is on and with the PROG LED blinking it warns of objects detected by the photocells (connected to PARTIAL STOP) or non-operation of the same.
- «**ST**» Yellow LED. Normally off.
When it is on and with the PROG LED blinking it means the TOTAL STOP button has been pushed, or non-operation of the same.

10 Activating the remote control

Antenna

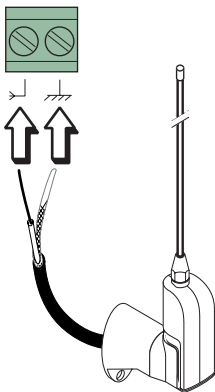

Connect the antenna's RG58 cable to the opposite terminals.



Possible output of the radio receiver's second channel (N.O. socket).
Socket rating: 5A-24V (d.c.).

Radiofrequency card

Only for cards shown on the table:

- place the jumper as shown depending on the series of transmitters used.

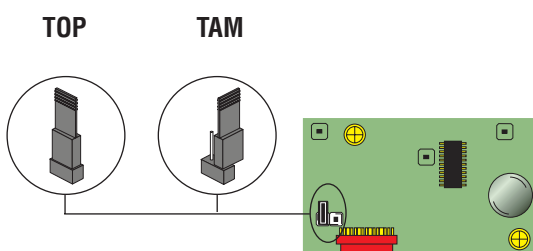

Frequency/MHz	radiofrequency card	Series of transmitters
FM 26.995	AF130	TFM
FM 30.900	AF150	TFM
AM 26.995	AF26	TOP
AM 30.900	AF30	TOP
AM 433.92	AF43S / AF43SM	TAM / TOP
AM 433.92	AF43SR	ATOMO
AM 40.685	AF40	TOUCH

Lock the radiofrequency card into the electronic card AFTER CUTTING OFF THE POWER SUPPLY (or after disconnecting the batteries).

N.B.: the electronic card only recognises the radiofrequency card when the power is on.

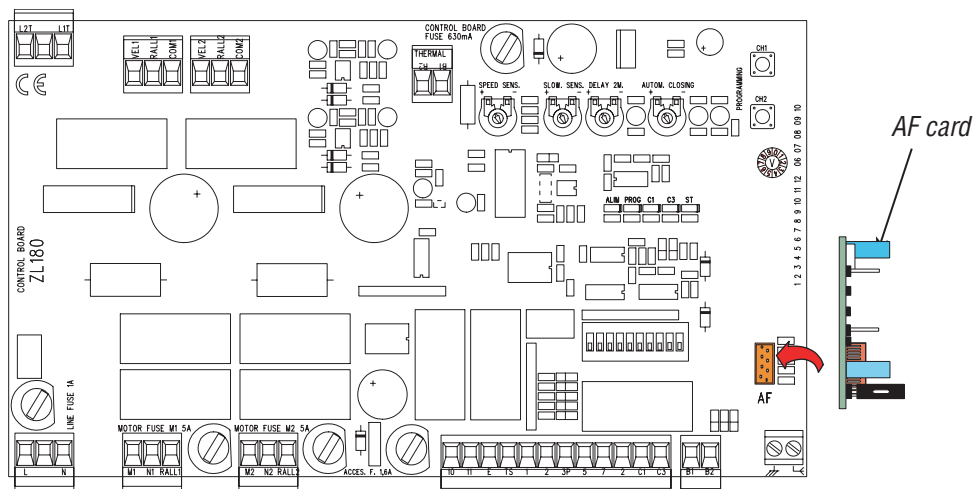

Transmitters

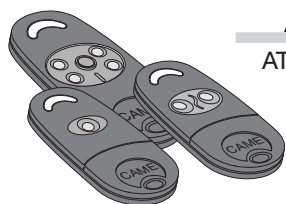

ATOMO
AT01 • AT02
AT04

See instructions attached to AF43SR radiofrequency card

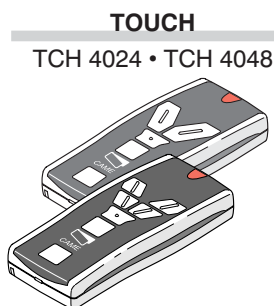

TOUCH
TCH 4024 • TCH 4048

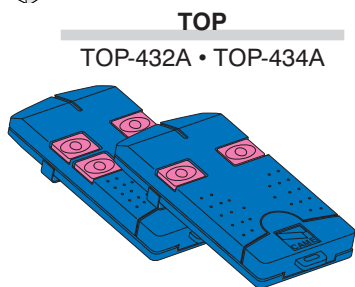

TOP
TOP-432A • TOP-434A

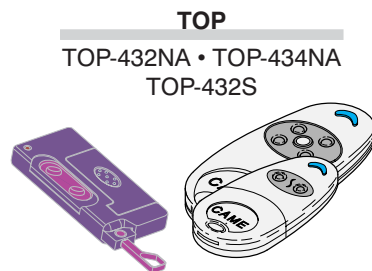

TOP
TOP-432NA • TOP-434NA
TOP-432S

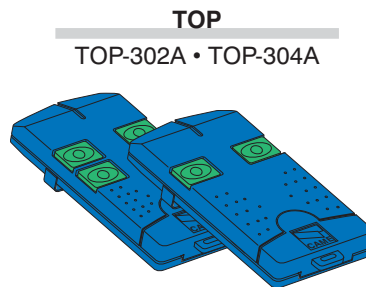

TOP
TOP-302A • TOP-304A

See attached instructions

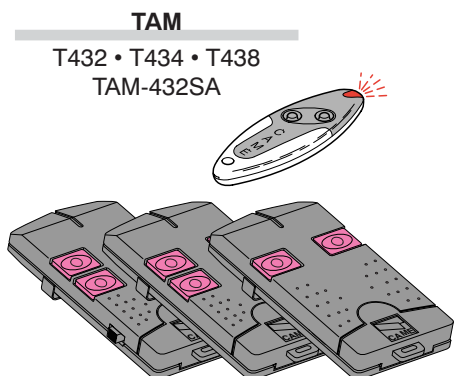

TAM
T432 • T434 • T438
TAM-432SA

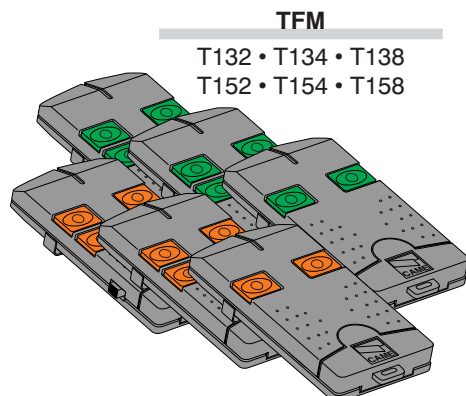

TFM
T132 • T134 • T138
T152 • T154 • T158

The data and information in this catalogue may change without prior notice from CAME cancelli automatici s.p.a.

Memorisation

CH1 = Channel for direct command to a function of the the gearmotor's card, ("open only / "open-close-invert" or "open-stop-close-stop" command, depending on the choice made on DIP switches 2 and 3).

CH2 = Channel for direct command an accessory device connected to B1-B2.

1) Keep the CH1 button on the electronic card pressed. The LED flashes.

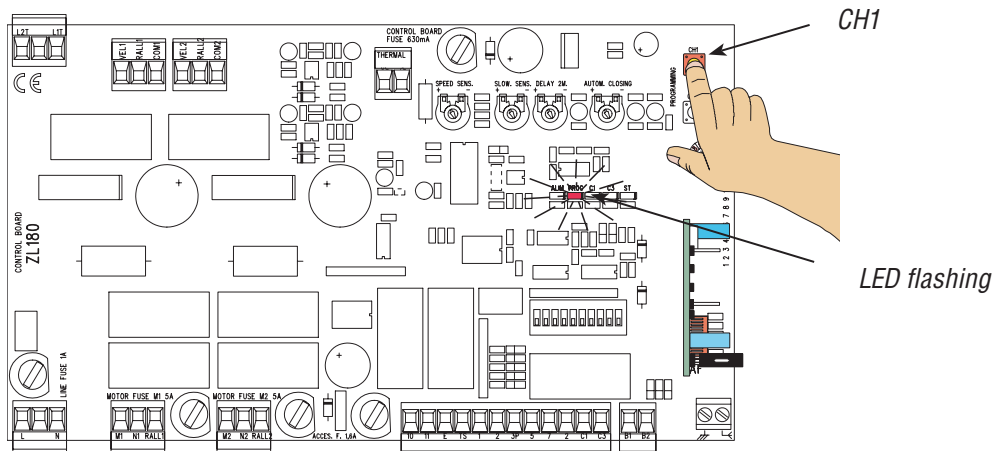

2) Press the transmitter button you wish to memorise. The LED will stay on to show memorisation has been successful.

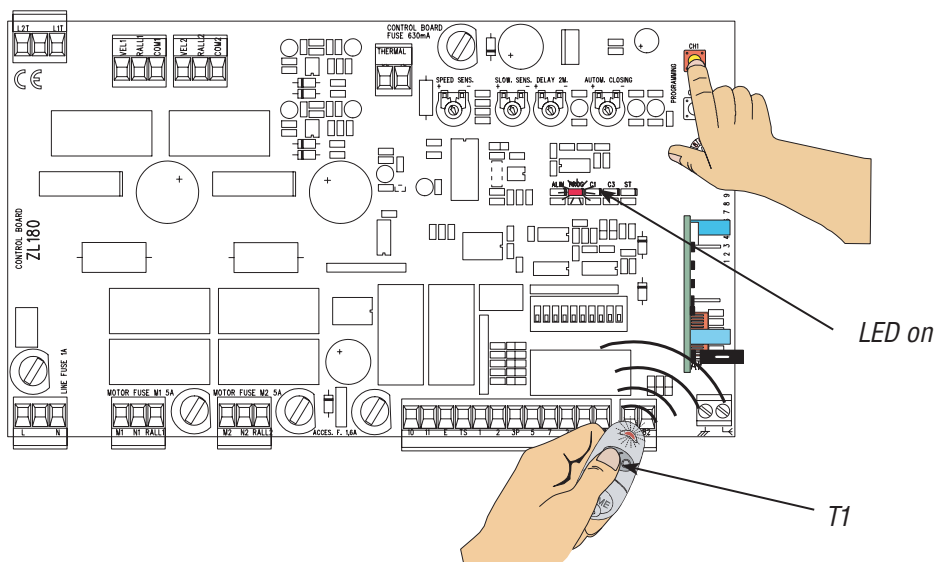

3) Repeat the points 1 and 2 procedures for the "CH2" button associating this to another button on the transmitter.

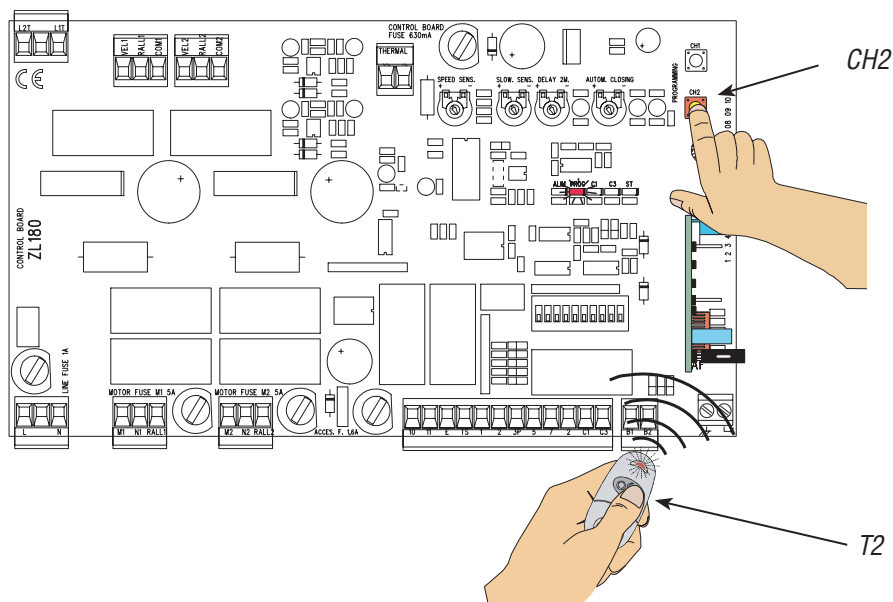

11 Phasing out and disposal



Our products are made with different types of materials. The majority of these (aluminium, plastic, iron and electrical cables) are part of the solid urban waste category. They can be recycled through licensed waste disposal plants.



Other components (electronic cards, remote control batteries, etc.) constitute hazardous waste. Thus, they are to be removed and delivered to licensed firms that specialise in their proper disposal.

12 Conformity declaration



MANUFACTURER'S DECLARATION OF CONFORMITY

Pursuant to annex II B of the Machinery Directive 98/37/EC



CAME Cancelli Automatici S.p.A.
via Martiri della Libertà, 15
31030 Dosson di Casier - Treviso - ITALY
tel (+39) 0422 4940 - fax (+39) 0422 4941
internet: www.came.it - e-mail: info@came.it

--- STANDARDS ---

EN 13241-1

EN 12453

EN 12445

EN 12635

EN 12978

EN 60335-1

EN 61000-6-2

EN 61000-6-3

Declares under its own responsibility that the equipments for automatic garage doors and gates listed below:

ZL180

... comply with the National Law related to the following European Directives and to the applicable parts of the following Standards.

--- DIRECTIVES ---

98/37/CE - 98/79/CE

98/336/CEE - 92/31/CEE

73/23/CEE - 93/68/CE

89/106/CEE

MACHINERY DIRECTIVE

ELECTROMAGNETIC COMPATIBILITY DIRECTIVE

LOW VOLTAGE DIRECTIVE

CONSTRUCTION PRODUCTS DIRECTIVE

IMPORTANT WARNING!

**Do not use the equipment specified here above, before completing the full installation
In full compliance with the Machinery Directive 98/37/EC**

MANAGING DIRECTOR

Mr. Andrea Menuzzo

Reference code to request a true copy of the original: **DDF B EN A001D**

CAME UNITED KINGDOM LTD

UNIT 3, ORCHARD BUSINESS PARK
TOWN STREET, SANDIACRE
NOTTINGHAM - NG10 5BP - U.K.

Tel - 0044 115 9210430

Fax - 0044 115 9210431

