

Combi 740[®]

Underground oil-hydraulic operator for swinging gates

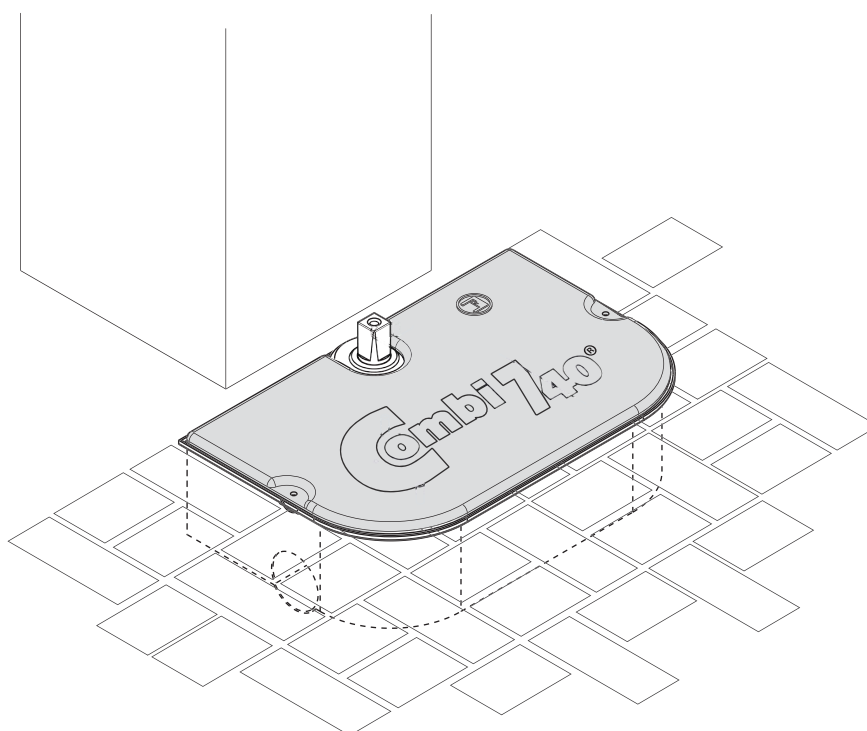

110° or 175° shaft rotation

Compact all-in-one oil-hydraulic motor-pump and jack

Reversible or bidirectional locking versions

Models with or without hydraulic braking device

Models with or without flow regulator

GENERAL WARNINGS FOR PEOPLE SAFETY**THANK YOU**

Thank you for purchasing a Fadini product. Please read these instructions carefully before using this appliance. The instructions contain important information which will help you get the best out of the appliance and ensure safe and proper installation, use and maintenance. Keep this manual in a convenient place so that you can always refer to it for the safe and proper use of the appliance.

INTRODUCTION

This operator is designed for a specific scope of applications as indicated in this manual, including safety, control and signaling accessories as minimum required with Fadini equipment. □ Any applications not explicitly included in this manual may cause operation problems or damages to properties and people. □ Meccanica Fadini S.r.l. is not liable for damages caused by the incorrect use of the equipment, or for applications not included in this manual or for malfunctioning resulting from the use of materials or accessories not recommended by the manufacturer. □ The manufacturer reserves the right to make changes to its products without prior notice. □ All that is not explicitly indicated in this manual is to be considered not allowed.

BEFORE INSTALLATION

Before commencing operator installation assess the suitability of the access, its general condition and the structure. □ Make sure that there is no risk of impact, crushing, shearing, conveying, cutting, entangling and lifting situations, which may prejudice people safety. □ Do not install near any source of heat and avoid contacts with flammable substances. □ Keep all the accessories able to turn on the operator (transmitters, proximity readers, key-switches, etc) out of the reach of the children. □ Transit through the access only with stationary operator. □ Do not allow children and/or people to stand in the proximity of a working operator. □ To ensure safety in the whole movement area of a gate it is advisable to install photocells, sensitive edges, magnetic loops and detectors. □ Use yellow-black strips or proper signals to identify dangerous spots. □ Before cleaning and maintenance operations, disconnect the appliance from the mains by switching off the master switch. □ If removing the actuator, do not cut the electric wires, but disconnect them from the terminal box by loosening the screws inside the junction box.

INSTALLATION

All installation operations must be performed by a qualified technician, in observance of the Machinery Directive 2006/42/CE and safety regulations EN 12453 - EN 12445. □ Verify the presence of a thermal-magnetic circuit breaker 0,03 A - 230 V - 50 Hz upstream the installation. □ Use appropriate objects to test the correct functionality of the safety accessories, such as photocells, sensitive edges, etc. □ Carry out a risk analysis by means of appropriate instruments measuring the crushing and impact force of the main opening and closing edge in compliance with EN 12445.

□ Identify the appropriate solution necessary to eliminate and reduce such risks. □ In case where the gate to automate is equipped with a pedestrian entrance, it is appropriate to prepare the system in such a way to prohibit the operation of the engine when the pedestrian entrance is used. □ Apply safety nameplates with CE marking on the gate warning about the presence of an automated installation. □ The installer must inform and instruct the end user about the proper use of the system by releasing him a technical dossier, including: layout and components of the installation, risk analysis, verification of safety accessories, verification of impact forces and reporting of residual risks.

INFORMATION FOR END-USERS

The end-user is required to read carefully and to receive information concerning only the operation of the installation so that he becomes himself responsible for the correct use of it. □ The end-user shall establish a written maintenance contract with the installer/maintenance technician (on -call). □ Any maintenance operation must be done by qualified technicians. □ Keep these instructions carefully.

WARNINGS FOR THE CORRECT OPERATION OF THE INSTALLATION

For optimum performance of system over time according to safety regulations, it is necessary to perform proper maintenance and monitoring of the entire installation: the automation, the electronic equipment and the cables connected to these. □ The entire installation must be carried out by qualified technical personnel, filling in the Maintenance Manual indicated in the Safety Regulation Book (to be requested or downloaded from the site www.fadini.net/supporto/downloads).

□ Operator: maintenance inspection at least every 6 months, while for the electronic equipment and safety systems an inspection at least once every month is required. □ The manufacturer, Meccanica Fadini S.r.l., is not responsible for non-observance of good installation practice and incorrect maintenance of the installation.

DISPOSAL OF MATERIALS

Dispose properly of the packaging materials such as cardboard, nylon, polystyrene etc. through specializing companies (after verification of the regulations in force at the place of installation in the field of waste disposal). Disposal of electrical and electronic materials: to remove and dispose through specializing companies, as per Directive 2012/19/UE. Disposal of substances hazardous for the environment is prohibited.

**CE DECLARATION OF CONFORMITY of the manufacturer:**

Meccanica Fadini S.r.l. (Via Mantova, 177/A - 37053 Cerea - VR - Italy) declares under own responsibility that: **Combi 740** complies with the 2006/42/CE Machinery Directive, and also that it is sold to be installed in an "automatic system", along with original accessories and components as indicated by the manufacturing company. An automatic gate operator is, by law, a "machinery" and therefore the installer must fit the equipment with all of the applicable safety norms. The installer is also required to issue the installer's Declaration of Conformity. The manufacturer is not liable for possible incorrect use of the product. The product complies with the following specific norms: analysis of the risks and subsequent action to cure them as per EN 12445 and EN 12453, Low Voltage Directive 2014/35/UE, Electromagnetic Compatibility 2014/30/UE. In order to certify the product, the manufacturer declares under own responsibility the compliance with the EN 13241-1 PRODUCT NORMS.

Tested and certified: CE marking and type testing according to ITT PDC No. 2393-2008.

Meccanica Fadini S.r.l.
Director in charge

MAIN COMPONENTS OF THE UNDERGROUND OIL-HYDRAULIC OPERATOR

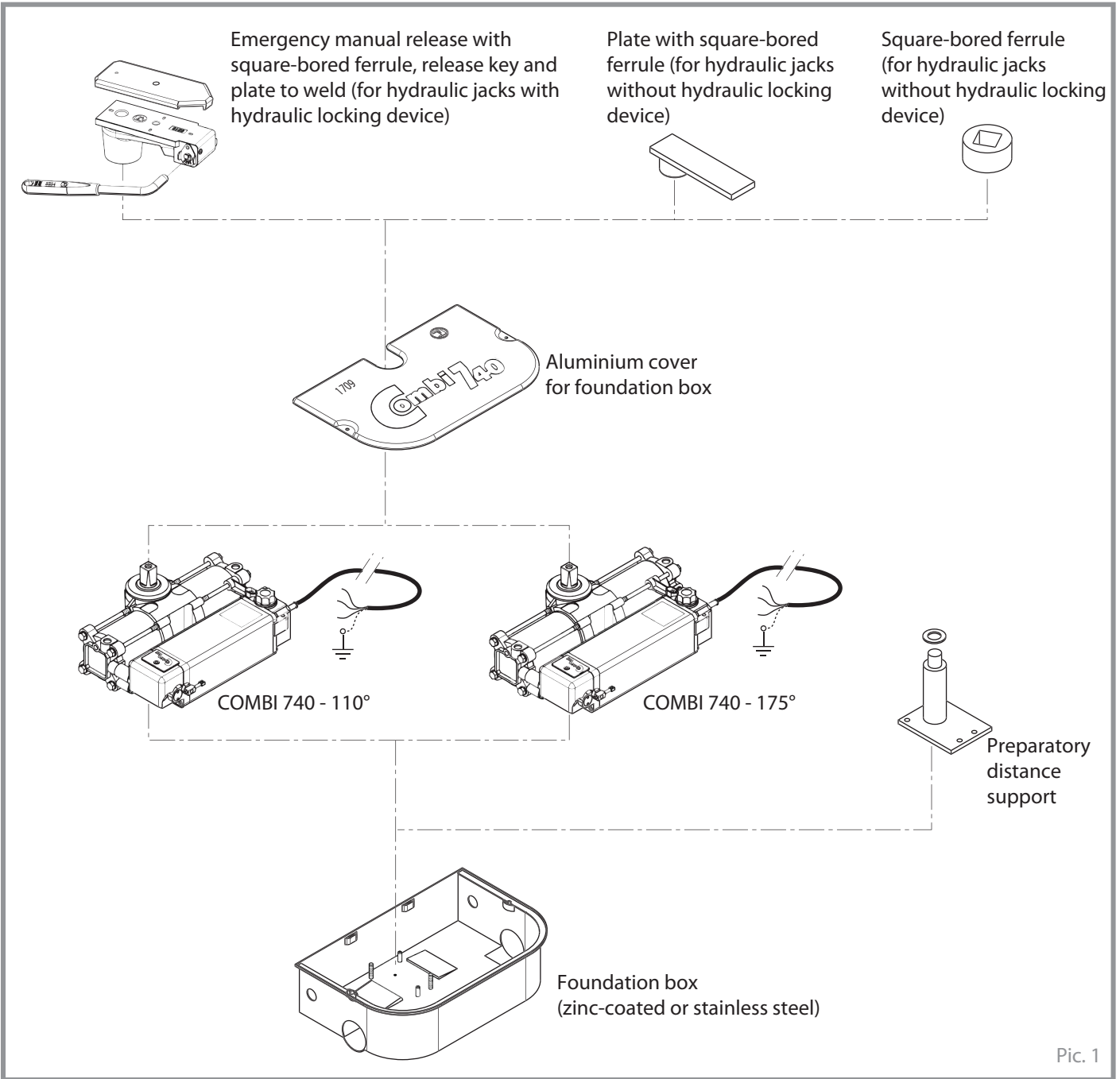

Pic. 1

DESCRIPTION OF JACK / MOTOR-PUMP COMPONENTS

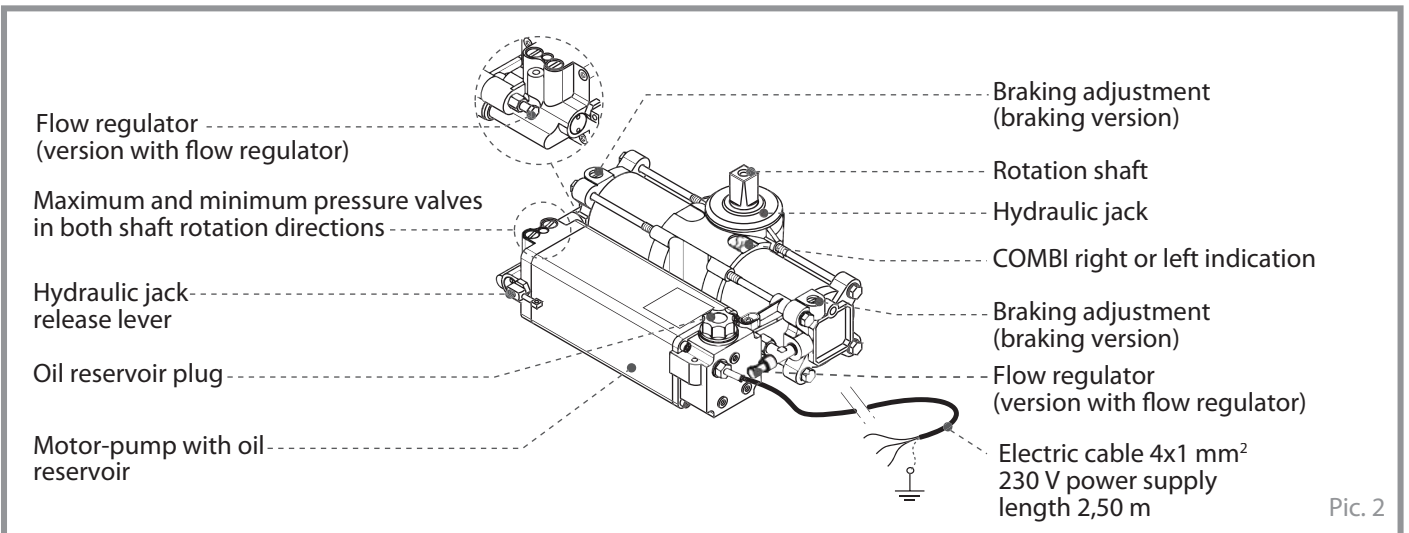

Pic. 2

INSTRUCTIONS TO BE FOLLOWED BEFORE INSTALLING THE OPERATOR

To ensure a perfect installation and operation of COMBI 740 keep to the following explanatory points and relative drawings.

IMPORTANT: the entire installation process must be carried out by qualified, technical people in compliance with EN 12453 - EN 12445 safety standards, and in accordance with the Machinery Directive 2006/42/CE.

Carry out a careful analysis of the risks in accordance with the safety regulations in force.

GENERAL DESCRIPTION: COMBI 740 is an oil-hydraulic automatic operator designed to open and close swinging gates for residential and commercial applications, studied for heavy duty installations, both in private and public areas.

It is an oil-hydraulic operator with a built-in motor-pump unit; the entire operator is housed inside a specifically designed foundation box, cemented underground at the base of the gate in correspondence with the rotation hinges.

COMBI 740 is a handed unit, either right- or left-handed (gates viewed from inside). Being oil-hydraulic, it can offer all the advantages that this feature allows such as reliability, smooth movements, adjustable thrust powers by maximum and minimum pressure valves to suit any kind of swinging gates.

Available in a wide range of options to meet any installation requirements: reversible without hydraulic locking device, with bidirectional hydraulic locking device in open and closed gate positions, braking in both gate travel directions and with flow regulator.

COMBI 740 requires a FADINI electronic control board, that must be installed in a sheltered place, for proper gate operations. The electronic board controls any operations as required either in automatic or semi-automatic modes, depending on the user's needs.

A series of commanding and safety accessories are available from catalogue to complete the installations.



Meccanica FADINI, as manufacturing company, is not liable should good technique of installation fail to be observed or other applications are made not included in this manual.

COMBI 740 VERSIONS

110° version = maximum shaft rotation 110°.

175° version = maximum shaft rotation 175°.

Reversible versions = 110° and 175° rotation options, without hydraulic locking device in both gate stop positions.
An electric gate lock is always recommended.

Locking version = 110° and 175° rotation options, with hydraulic locking device in both gate stop positions.

Braking version = 110° and 175° rotation options, with adjustable hydraulic braking device in both directions, over the last 40 cm of motion.

Version with flow regulator = 110° and 175° rotation options, with hydraulic flow regulator (it adjusts gate speed) in both gate travel directions for gates wider than 2,5 m each gate leaf.

COMBI 740 IDENTIFICATION STICKER

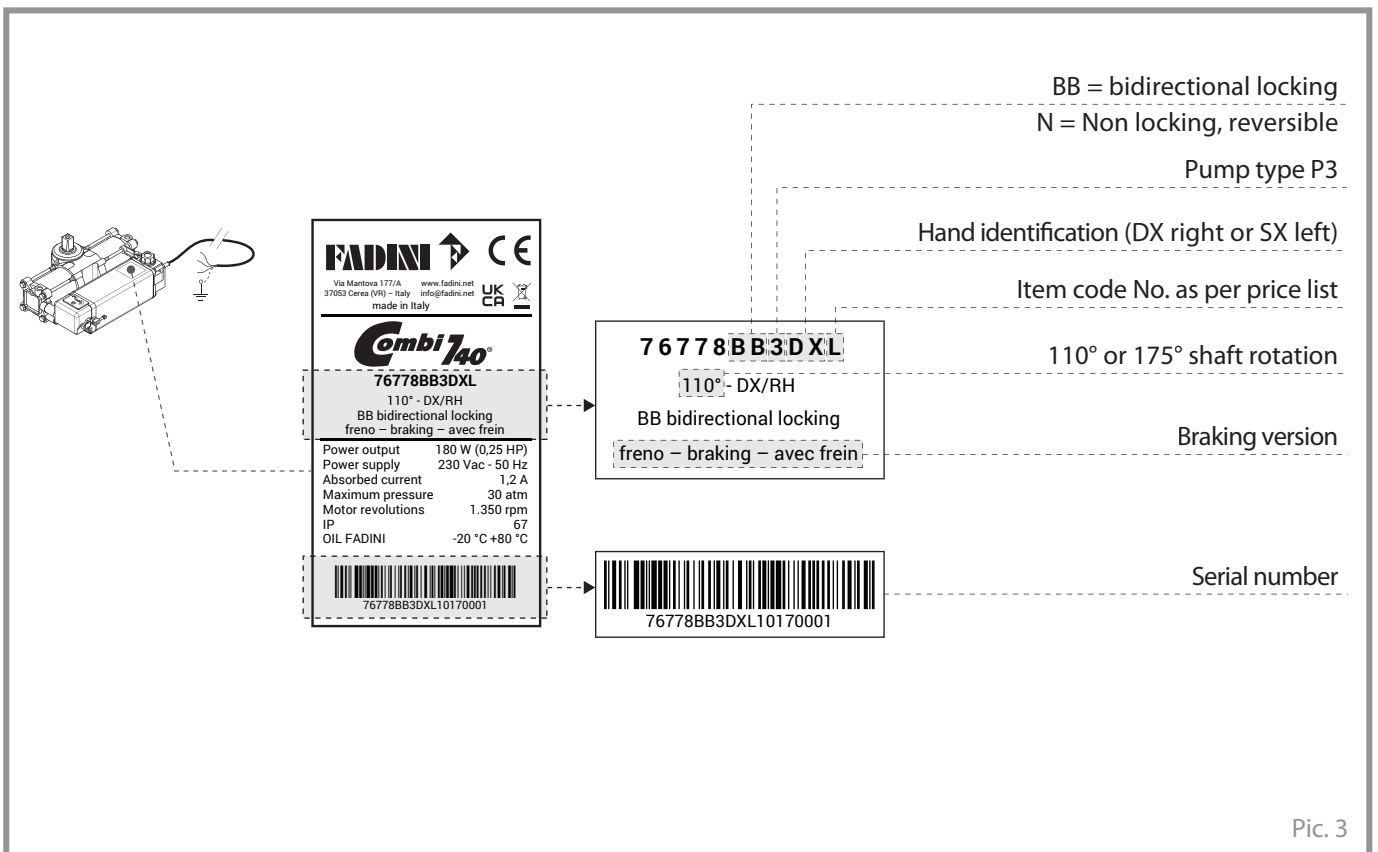

Pic. 3

MAIN COMPONENTS FOR A STANDARD INSTALLATION

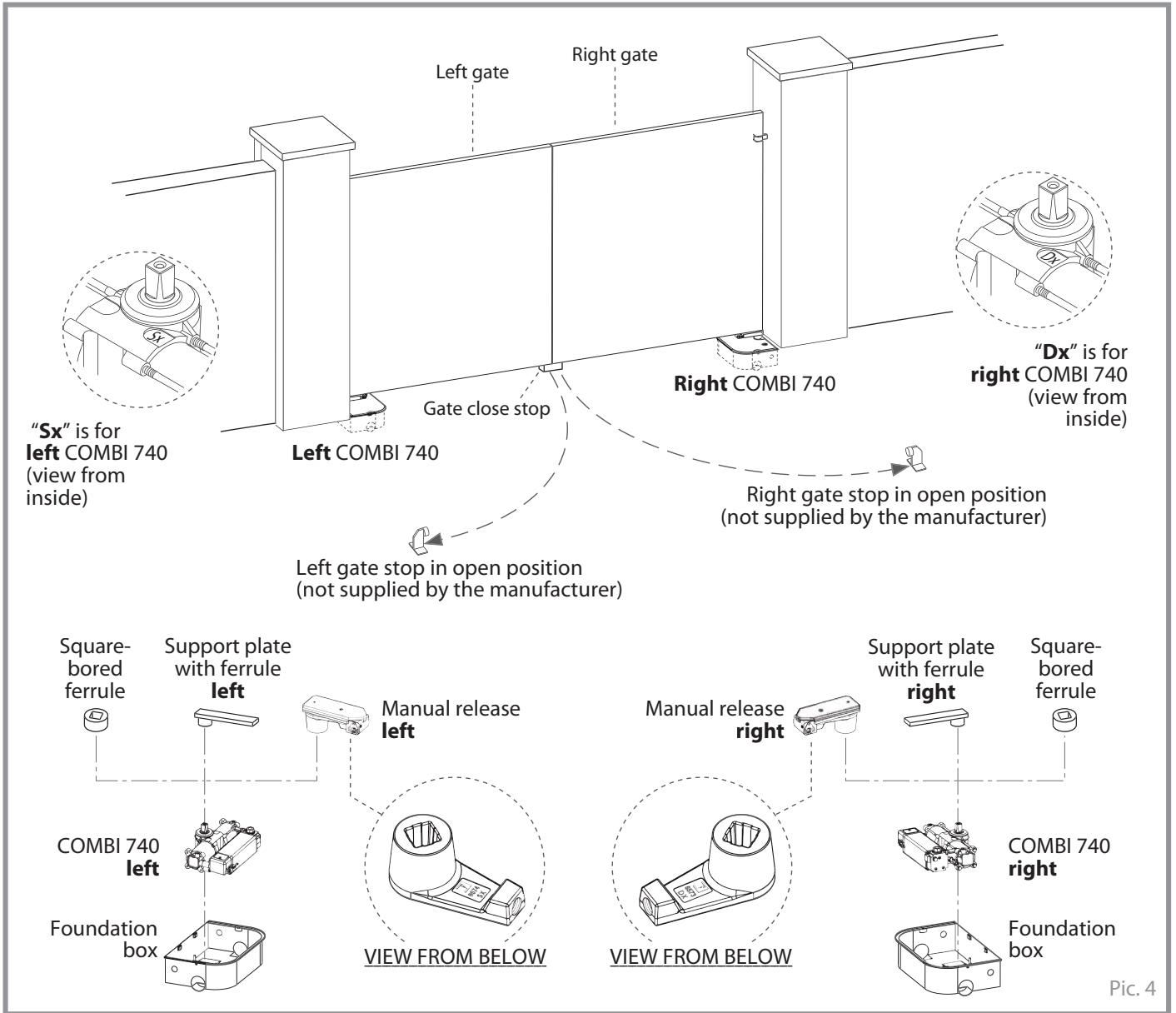

Pic. 4



Important: for installations with Combi 740 (reversible ie. non locking or locking) on gates longer than 2,0 m each it is always necessary to install an electric lock with a gate stop latch: the possible solutions are shown in Pic. 5 and Pic. 6. For single-leaf gates, it is recommended that the electric lock be installed horizontally.

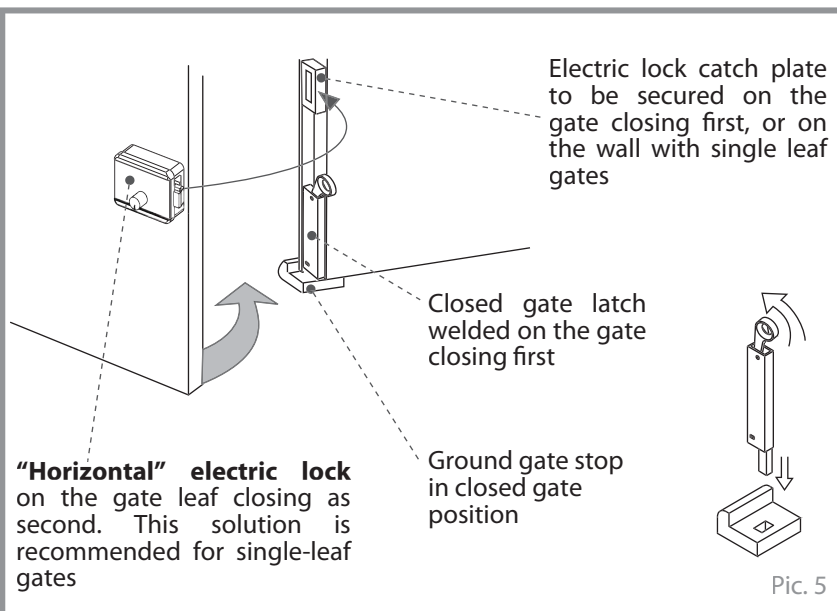

Pic. 5

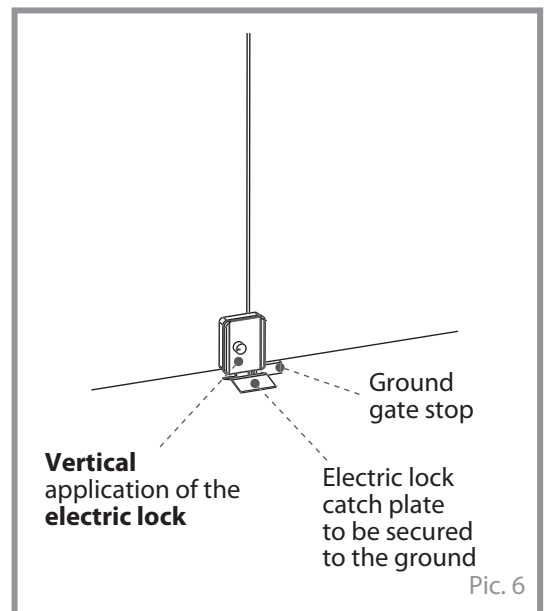

Pic. 6

IDEAL USE OF THE UNDERGROUND OIL-HYDRAULIC COMBI 740

- COMBI 740 Reversible version, 110° rotation:

- 1) COMBI 740 - 110° can suit any gate type, always with an electric lock.
- 2) For gate leafs wider than 2,50 m, COMBI 740 braking version is recommended.
- 3) COMBI 740 can bear a static gate weight of 700 kg, per gate leaf of 2,0 m width. Beyond this size gate weight is to decrease accordingly (Pic. 7).

- Combi 740 Locking version, 110° rotation:

- All previous three points apply.
- 4) The Combi 740 Locking is recommended for gate leafs up to 2,0 meters long, without an electric lock. An electric lock is always necessary for gate leafs that are longer than 2,0 m.

- Combi 740 Reversible version, 175° rotation:

All previous three points apply.

- Combi 740 Locking version, 175° rotation:

All previous four points apply.

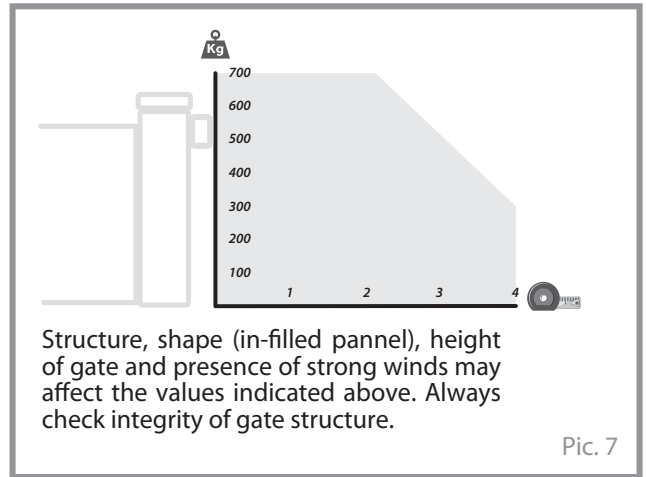

INSTALLING THE FOUNDATION BOX

WARNINGS:

ensure that the gate structure is suited to the operator and check to see if the fixed and moving parts require any special reinforcements for the installation, making sure that there are no obstacles or friction during the entire movement of the gate.

The **foundation box** must be cemented to the base of the gate in order to receive and secure the operator. However, the lower gate pivot must be removed first because the Combi 740 rotation shaft acts as a lower rotation pivot (Pic. 8).

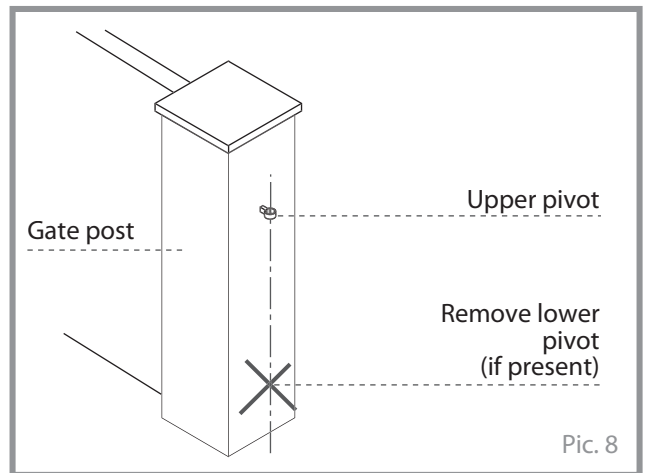

SETTING UP AND FIXING THE FOUNDATION BOX

Dig a hole at the base of the gate post in accordance with the measurements indicated in Pic. 9 and lay an underground pipe to connect the foundation box to the site where the electronic controller is installed (it is recommended that the controller be installed in a protected and dry place); the pipe must be of a suitable diameter to permit the passage of the operator's power cables (corrugated pipe $\varnothing 20 - \varnothing 25$ mm).

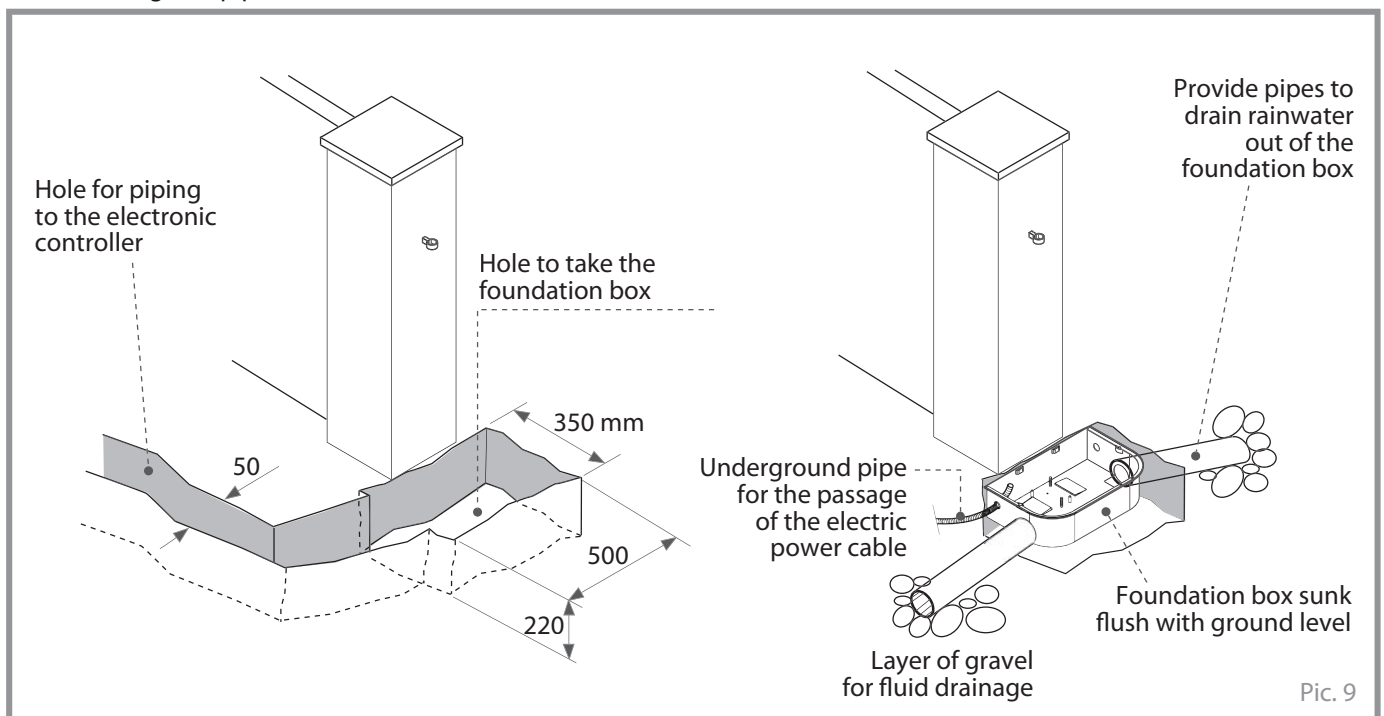

ALIGNMENT PHASE OF TWO FOUNDATION BOXES

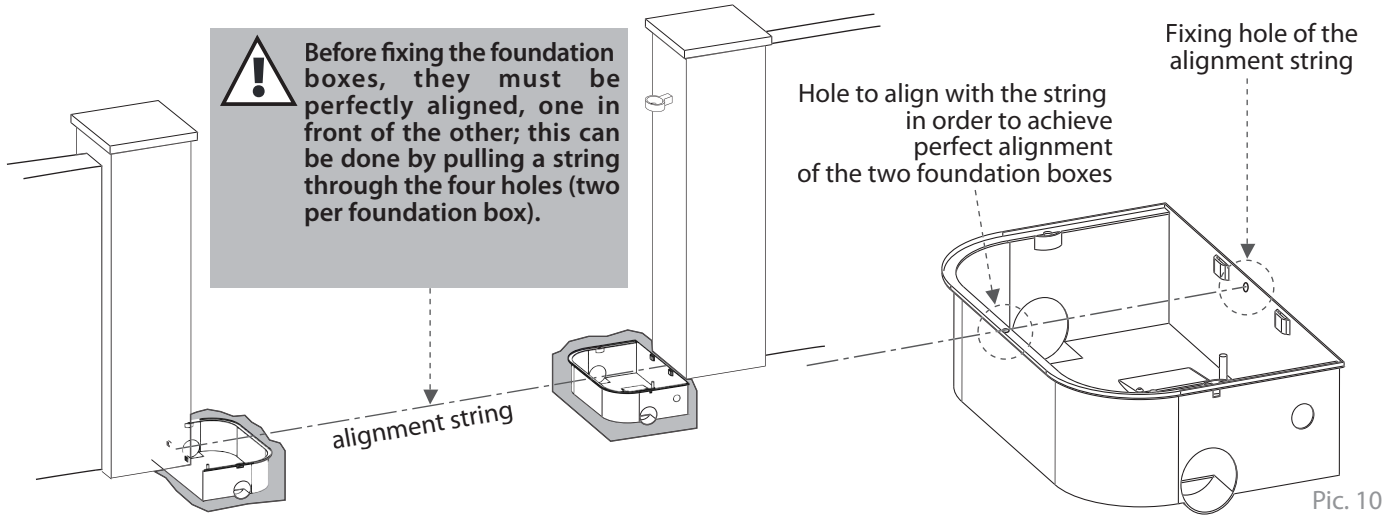

Note well: before fixing the foundation box with concrete, align the inner hole of the foundation box with the gate upper hinge (Pic. 11) and make sure the foundation box is perfectly levelled. The upper edge of the enclosure must be flush with the finished ground level.

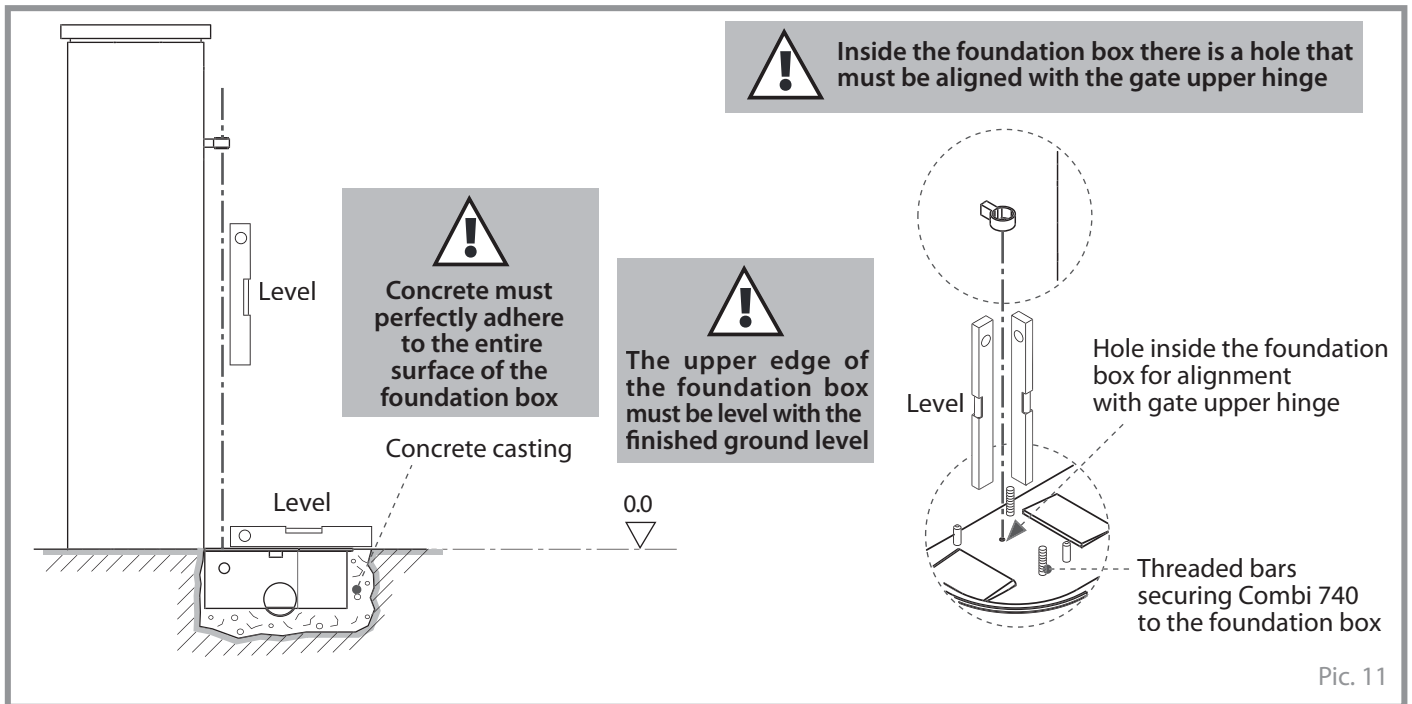

The gate can be installed even without Combi 740: the foundation box, actually, is pre-set to house the preparatory support which, once secured inside of it, replaces the lower gate hinge (Pic. 12).

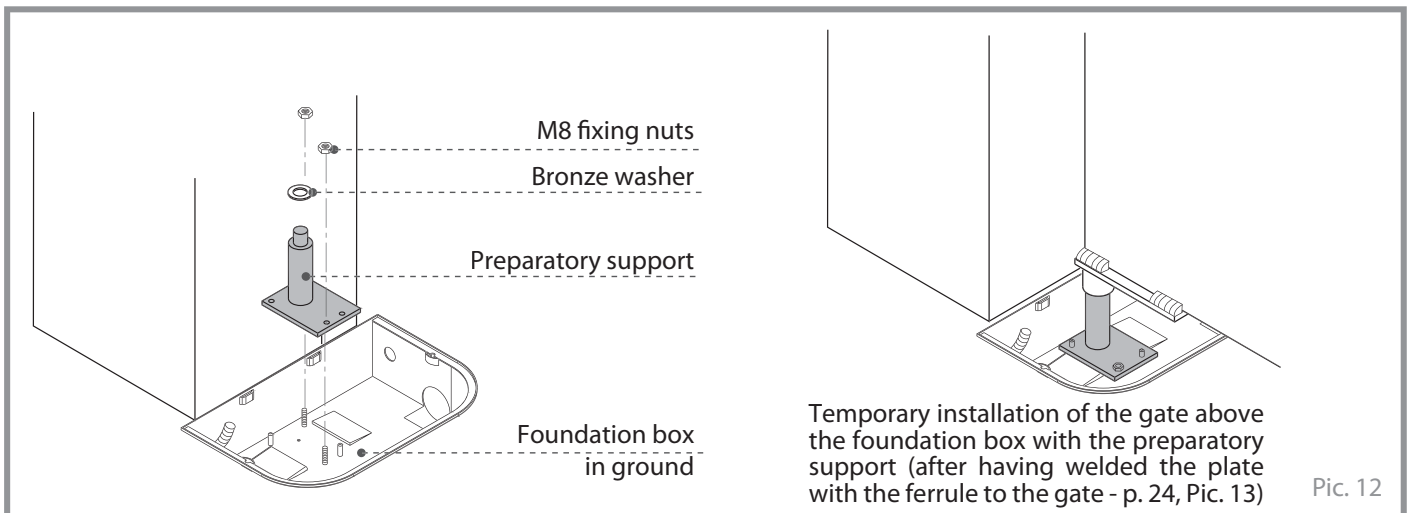

MEASUREMENTS OF THE VARIOUS INSTALLATION OPTIONS

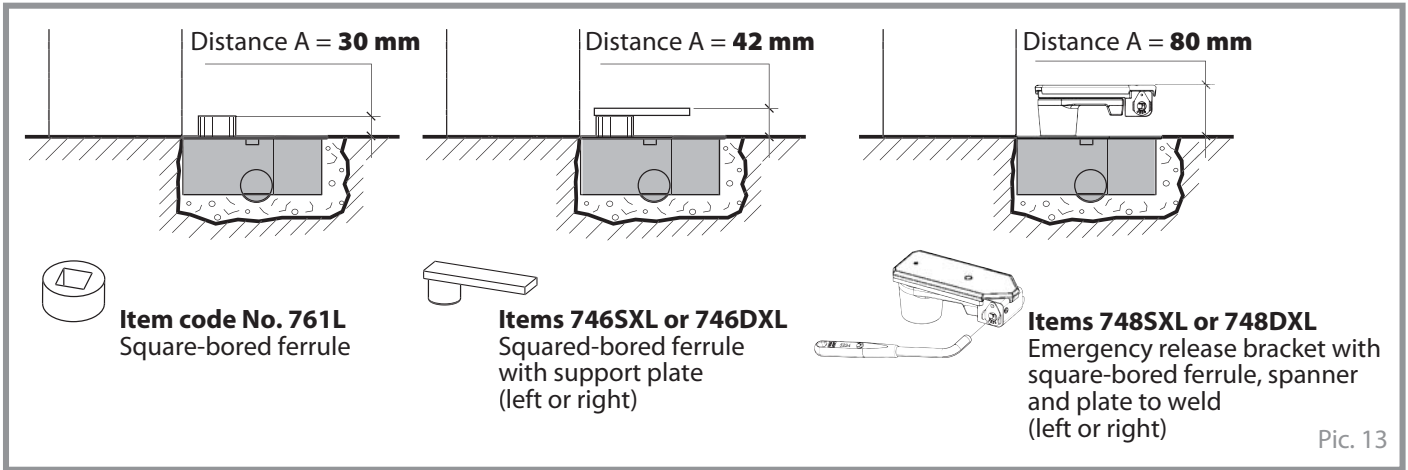

GATE PREPARATION: FIXING THE EMERGENCY RELEASE BRACKET OR THE FERRULE

The gate can be fixed onto the COMBI 740 operator in three different ways: by the emergency release bracket, the support plate with square-bored ferrule and the square-bored ferrule.

In all the cases, these elements are to be firmly welded to the base of the gate and aligned with the gate upper pivot (Pic. 14).

IMPORTANT: respect the distance indicated in Pic. 13, between the foundation box and the gate above it.

IMPORTANT TO ACHIEVE CORRECT PUTTING IN PHASE OF THE GATE: the plain square-bored ferrule must be welded to the gate leaf with COMBI 740 shaft rotated by 5° or 10°, before it reaches the end of the permitted stroke (Pic. 14).

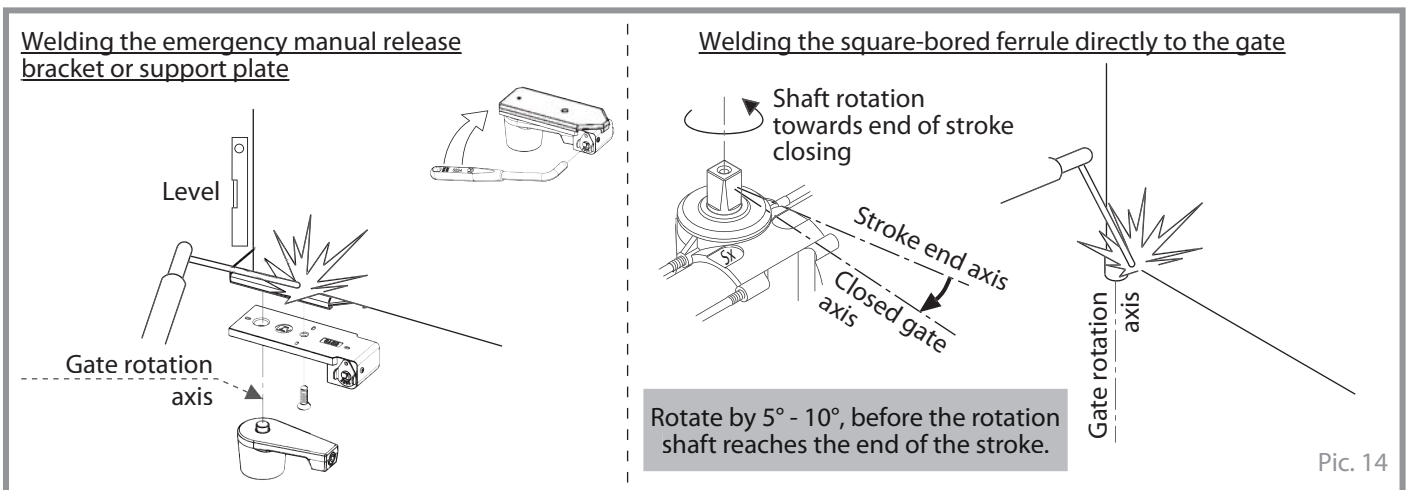

INSTALLING THE RIGHT AND LEFT COMBI 740s INSIDE THE RESPECTIVE FOUNDATION BOXES

IMPORTANT: The right and left COMBI 740s are installed respectively to the right and left of the gate (view from inside). The following abbreviations are marked on the bases of the COMBI 740 square rotation shafts (Pic. 15):

Sx = Left-hand version

Dx = Right-hand version

NOTE: all what previously described applies also to installations with single swinging gates.

IMPORTANT: before installing and wiring the operators, it is required that ground gate stops be fixed in the open gate positions (at about 5° before end of the permitted stroke) and in closed gate position.

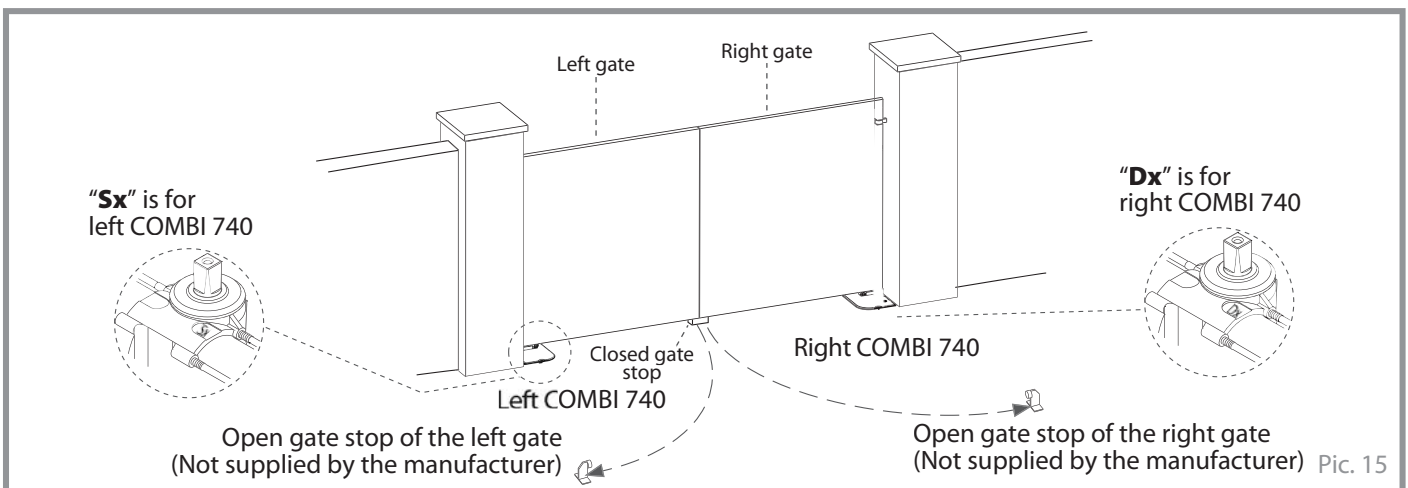

INSTALLING THE EMERGENCY MANUAL RELEASE BRACKET

IMPORTANT: On installing the manual release bracket, mind Pic. 16 and Pic. 17 very carefully:

The operation of matching the manual release bracket and the operator is different depending on the rotation angle.

Right COMBI 740 - 110° is to match the right emergency manual release bracket (in the same way, left Combi with left bracket) (Pic. 16).

Right COMBI 740 - 175° is to match the left emergency manual release bracket (on the other way, left Combi with right bracket) (Pic. 17).

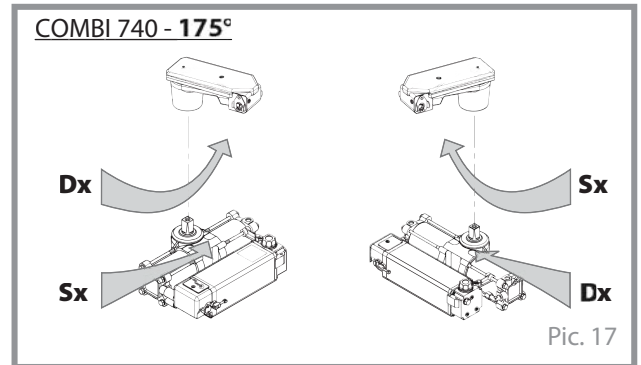
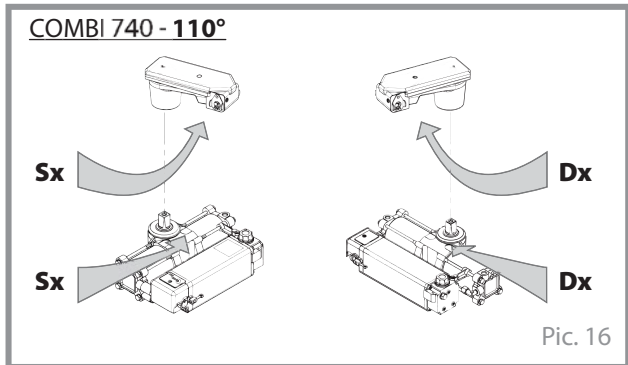

COMBI 740 is to be inserted into the foundation box, fixed by using the two hexagonal studs and held in place by the raised edges of the two slits in the foundation box base (Pic. 18).

After inserting the right and left COMBI 740s inside the respective foundation boxes, it is possible to finally install the gates.

IMPORTANT: before beginning any operations, even manual, make sure that proper gate stops are mounted in open and closed gate positions (Pic. 15 page 24).

RELEASING THE OPERATOR FOR MANUAL OPERATIONS OF THE GATES

COMBI 740 fitted with the emergency manual release bracket: insert the spanner into the manual release seat and do as indicated in Pic. 19.

COMBI 740 with the support plate fitted with square-bored ferrule or the plain square-bored ferrule: remove the lid of the COMBI 740 foundation box to directly access the jack/motor-pump assembly. Rotate the release lever positioned on the side of the motor-pump unit as indicated in Pic. 20.

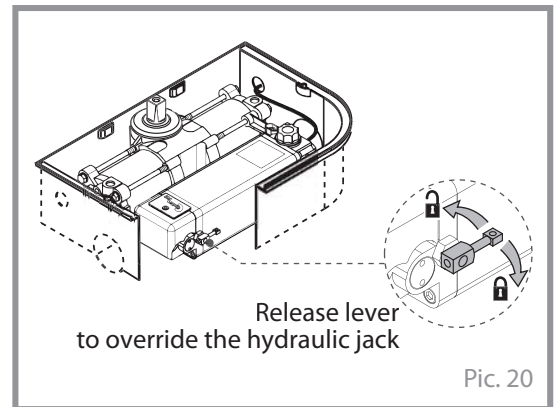
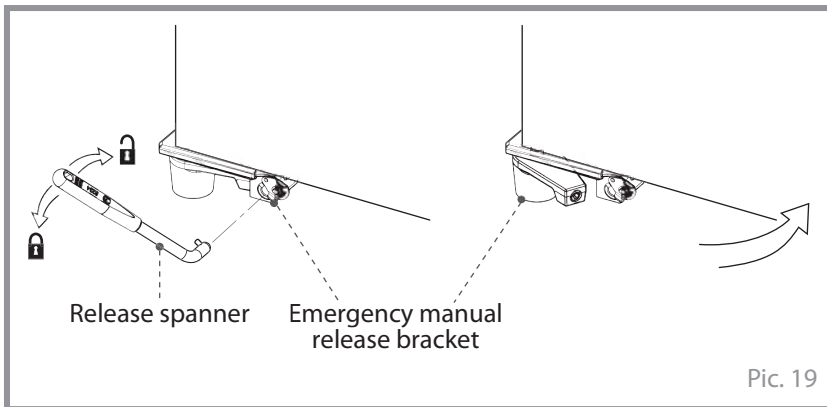
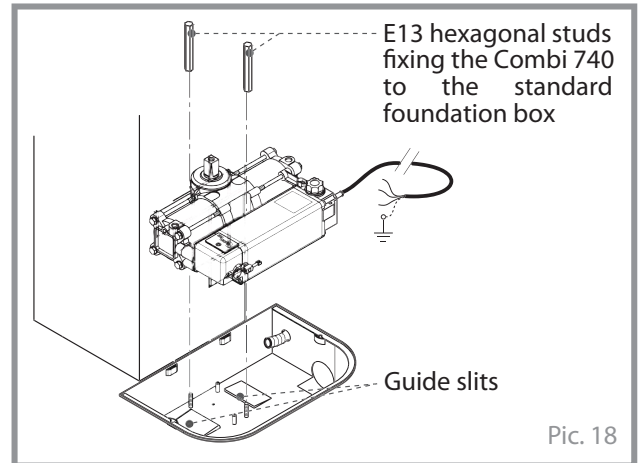

FIRST OPERATION TESTS

To carry out the first shaft rotation tests, power supply can be connected directly to the Combi 740 motor.

Make the connections in accordance with the diagram in Pic. 21, adding a 12,5 µF capacitor, parallel with the two phases. To reverse shaft rotation, swap phase connections.

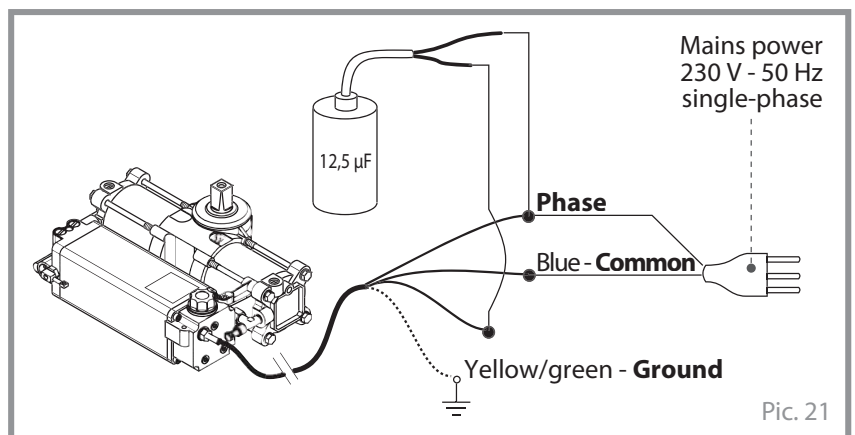

ADJUSTING THRUST FORCE

The anti-crashing safety of Combi 740 is ensured by the hydraulic maximum pressure valves, which allow for an accurate and stable adjustment of the thrust force over the time.

To access the thrust adjusting screws, undo the Allen screw and remove the cover (Pic. 22).

- **Red screw:** by **tightening** (clockwise) **thrust force is increased during closing**, and decreased by loosening.

- **Green screw:** by **tightening** (clockwise) **the thrust force is increased during opening**, and decreased by loosening.

English

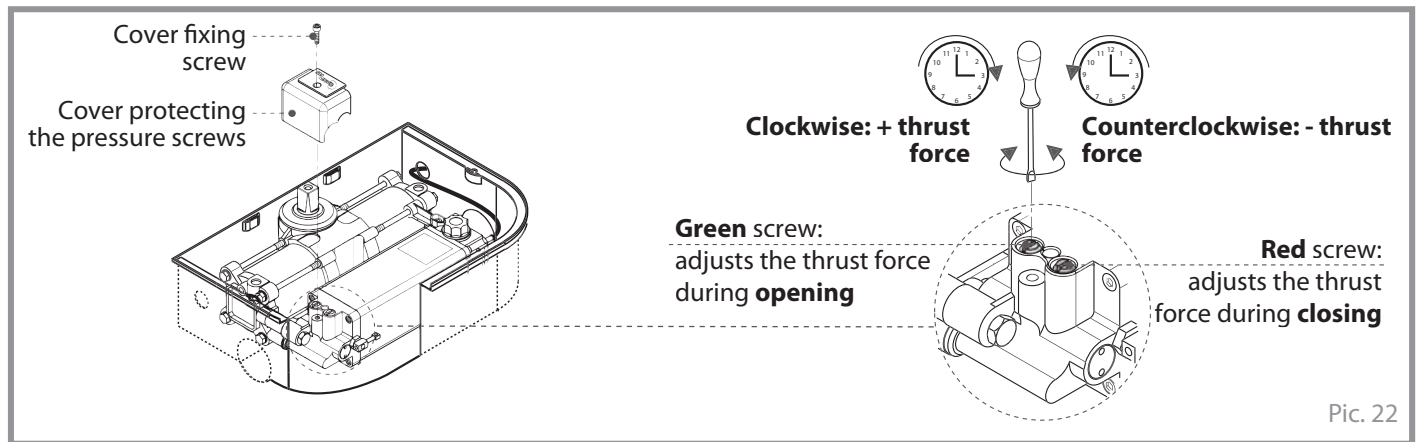

Pic. 22

BRAKE ADJUSTING (ONLY WITH COMBI 740 WITH BRAKING IN OPENING AND CLOSING)

It is possible to adjust braking i.e. slowdown during the last few rotation degrees of the gates (approx. 40 cm) as described in Pic. 23.

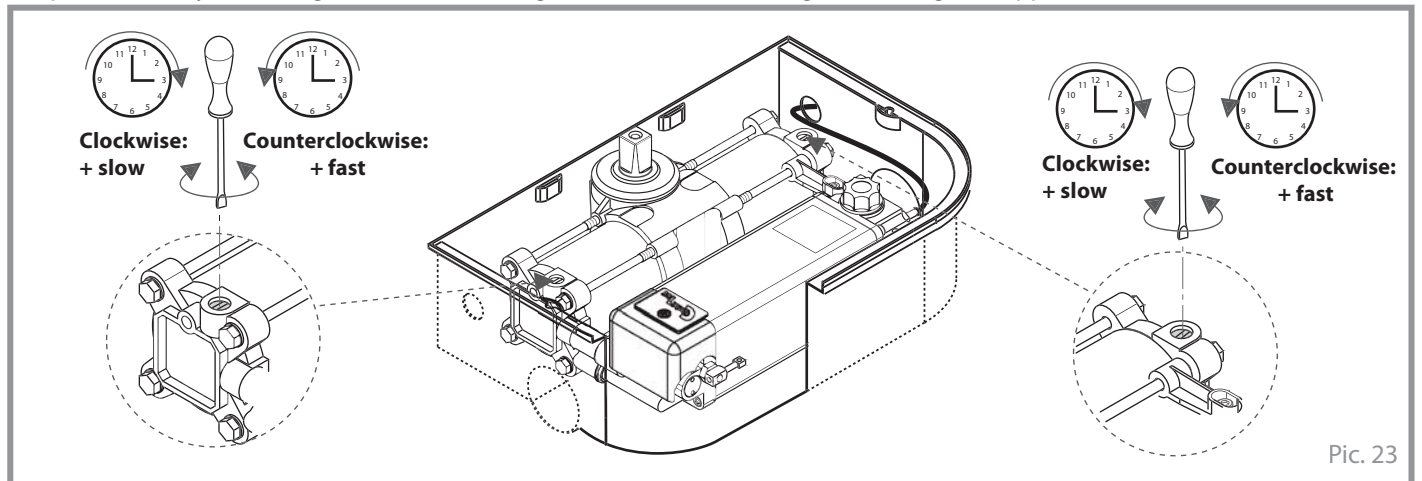

Pic. 23

SPEED CONTROL (ONLY WITH COMBI 740 WITH FLOW REGULATOR)

The hydraulic flow regulator allows for the gate peripheral speed to be adjusted as required through the entire movements of the gates in both directions, opening and closing (Pic. 24). This version is recommended for gate leaves wider than 2,5 m or in case of special installations where constant speed control of the gates is needed.

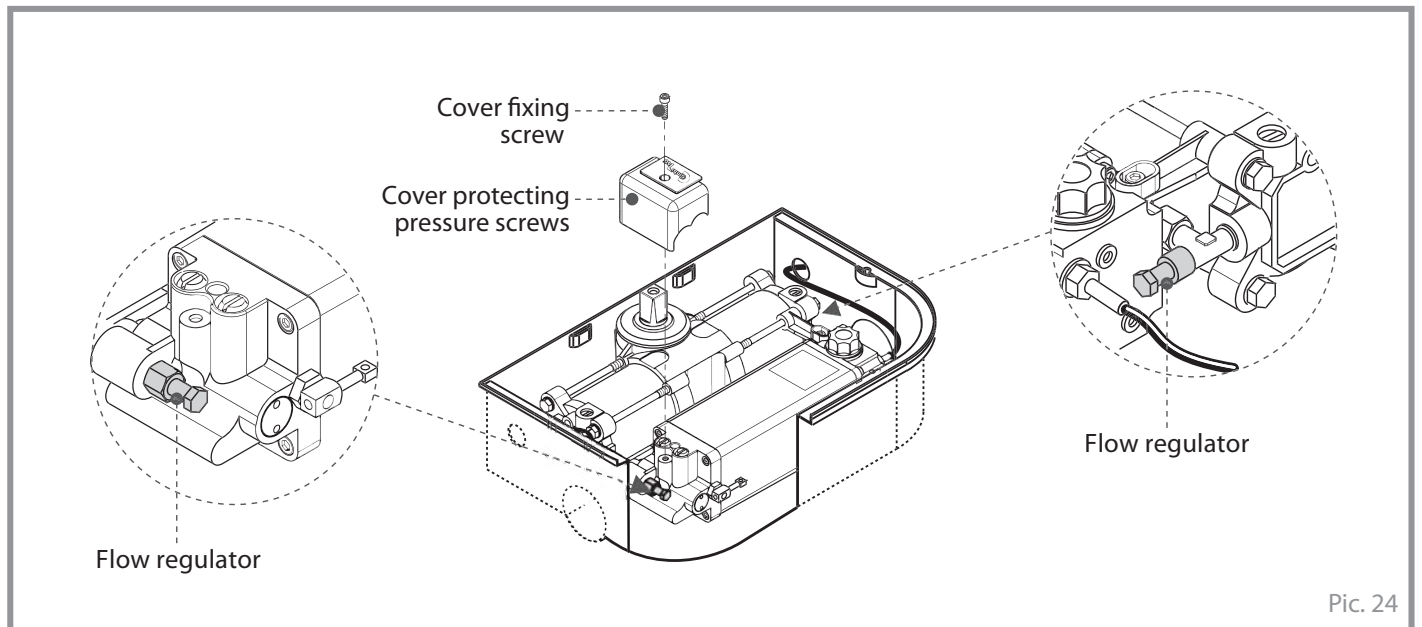

Pic. 24

APPLICATION OF COMBI 740 WITH OFF-AXIS DRIVING ARM - CODE 7033L

English

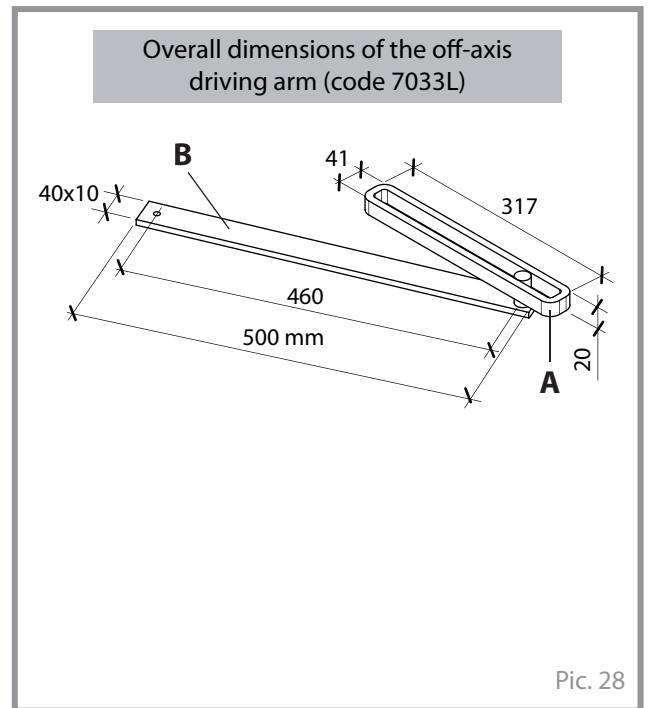
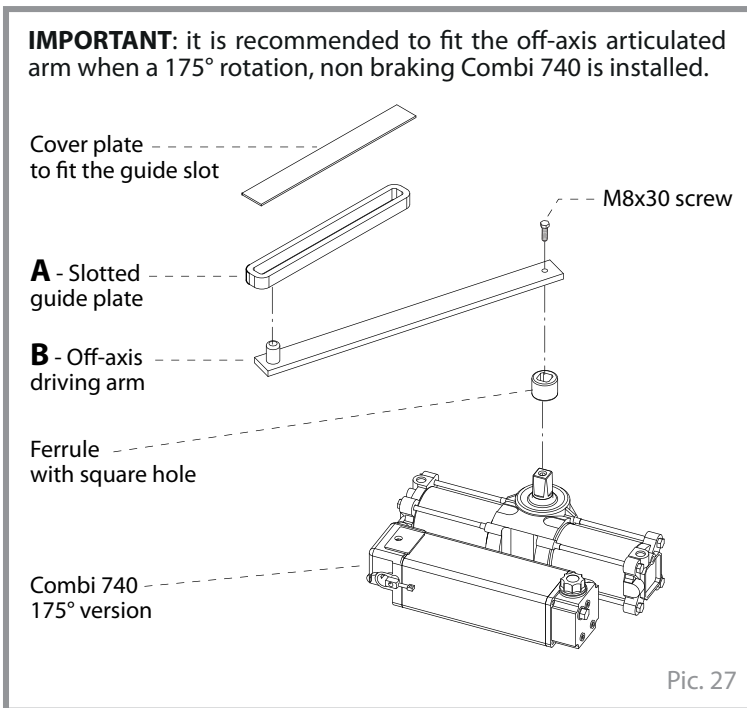
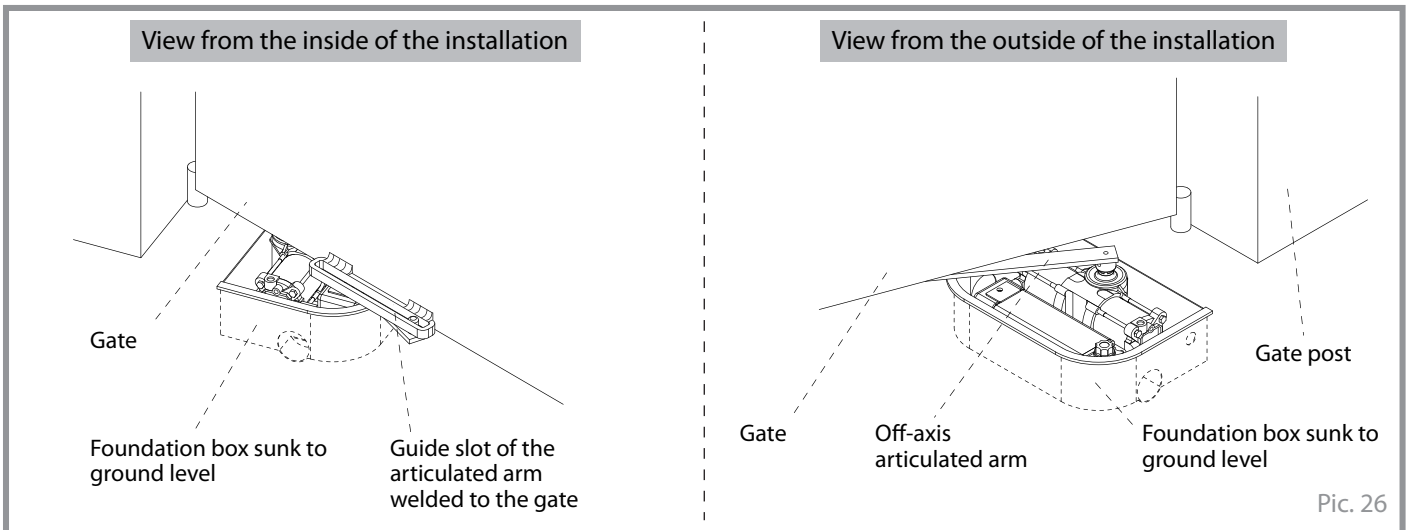
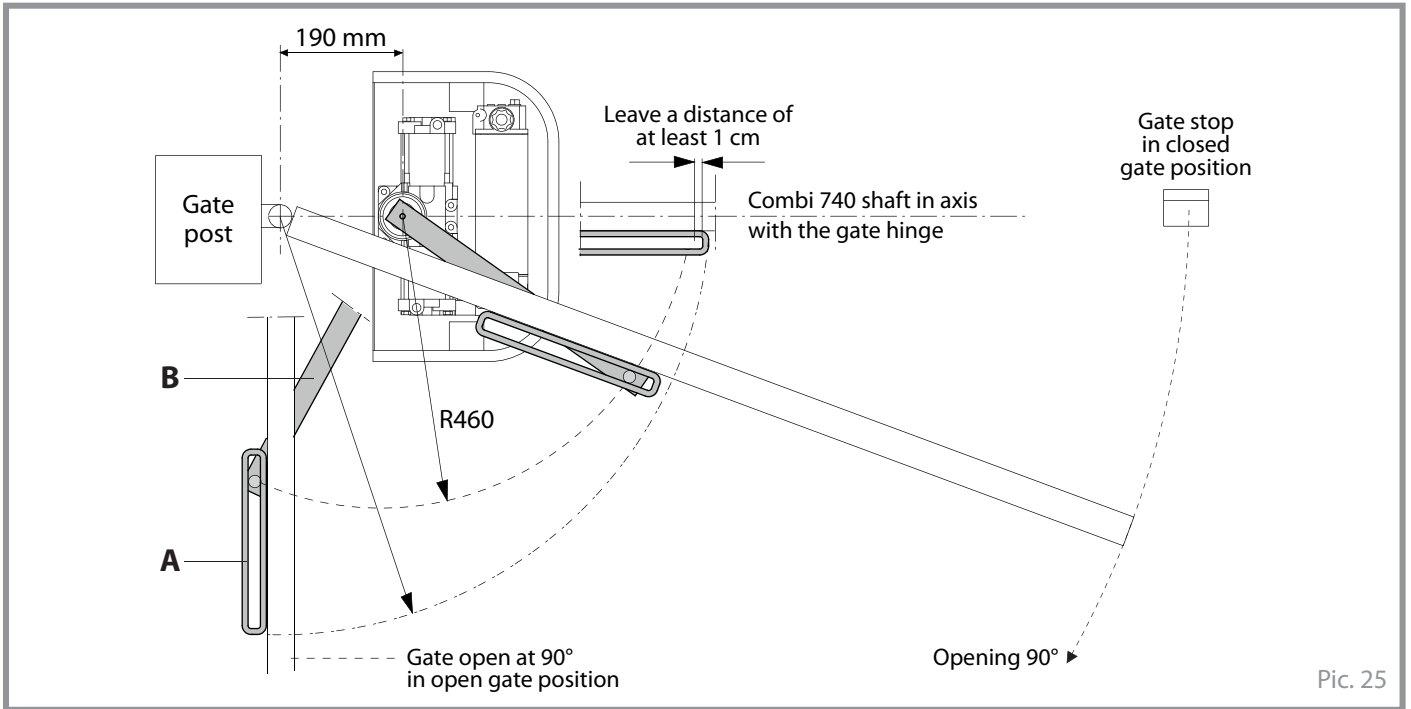

ELECTRICAL CONNECTIONS OF THE INSTALLATION

IMPORTANT: all the electrical connections and cables (Pic. 29) must comply with the rules of the art and the installation standards in accordance with the current laws in force (Machinery Directive 2006/42/CE); cabling and wiring must be carried out by qualified technicians, who are to formulate a complete analysis of the risks, to adopt appropriate safety measures in accordance with the **EN 12445** and **EN 12453** norms and to **fill in the technical dossier**.

- The **Elpro** controller should be installed in a dry, protected place, inside its own container; in case that components are added for the proper operation of the control and safety accessories, it is advised to install everything inside a box certified for outdoor use (not provided by the manufacturer).

- The **Elpro** controller can be powered by 1 mm² electrical cables, for a distance up to 50 meters maximum.

For distances longer than 50 meters, use electrical cables with wires of appropriate diameter, in accordance with the requirements of good installation technique.

For all the accessories outside the electrical panel, electrical cables with 1 mm² or 0,5 mm² wires can be used.

General diagram; it should be the installer's care to lay the tubes for the electric cables in the most suitable and correct way as required by the application site.

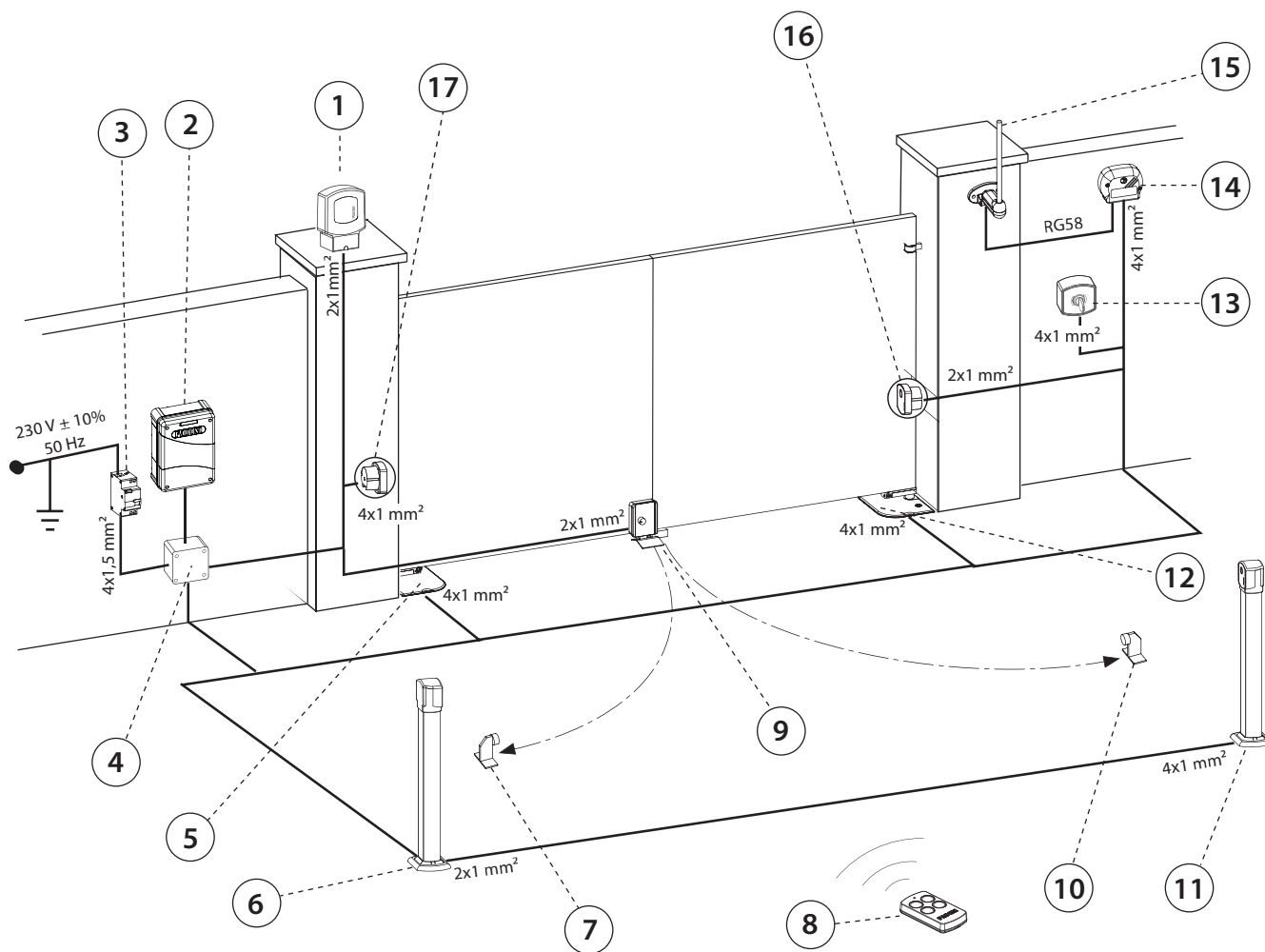

List of component items:

- | | |
|--|--|
| 1 - Flasher | 9 - Electric lock with catch plate with gates in closed position |
| 2 - Electronic controller | 10 - Gate stop in open position, right gate (not supplied by the manufacturer) |
| 3 - 230 V - 50 Hz magnetic-thermal 0,03 A circuit breaker (not supplied by the manufacturer) (beyond 100 m cable section 2,5 mm ²) | 11 - Photocell receiver (inside) on post |
| 4 - Junction box (not supplied by the manufacturer) | 12 - Right-handed Combi 740 |
| 5 - Left-handed Combi 740 | 13 - Key-switch |
| 6 - Photocell projector (inside) on post | 14 - Stand-alone radio receiver |
| 7 - Gate stop in open position, left gate (not supplied by the manufacturer) | 15 - Aerial |
| 8 - Transmitter | 16 - Photocell projector (outside) |
| | 17 - Photocell receiver (outside) |

GUIDANCE FOR PROPER USE (for the end user)

WARNINGS

- Transit across the gate is allowed only if motor is stopped; stand at safe distance during opening and/or closing cycles of the gate.
- Do not touch any components of the system while the operator is working.
- Do not allow children and/or people to stand in the proximity of a working operator.
- Keep all the accessories able to turn on the operator (transmitters, proximity readers, key-switches, etc.) out of the reach of the children.
- Do not run the system in case of anomalies.

DISPOSAL OF MATERIAL: dispose properly of the packaging materials such as cardboard, nylon, polystyrene etc. through specializing companies (after verification of the regulations in force at the place of installation in the field of waste disposal). Disposal of electrical and electronic materials: to remove and dispose through specializing companies, as per Directive 2012/19/UE. Disposal of substances hazardous for the environment is prohibited.

MAINTENANCE

For optimum performance of system over time according to safety regulations, it is necessary to perform proper maintenance and monitoring of the entire installation: the automation, the electronic equipment and the cables connected to these. The entire installation must be carried out by qualified technical personnel. Operator: maintenance inspection at least every 6 months, while for the electronic equipment and safety systems an inspection at least once every month is required. The manufacturer, Meccanica Fadini S.r.l., is not responsible for non-observance of good installation practice and incorrect maintenance of the installation.

Advice for the end user:

- clear the site of materials that may have deposited in the equipment and hinder its correct functioning (such as rests of insects, foliage, stones, etc.); before carrying out this operation, switch off voltage supply;
- clean regularly the equipment by using a damp cloth. Do not use flammable substances such as alcohol, solvents or benzene: these substances may cause explosions and/or damage the system.

Actuator releasing for manual operations of the gate fitted with the emergency manual release bracket

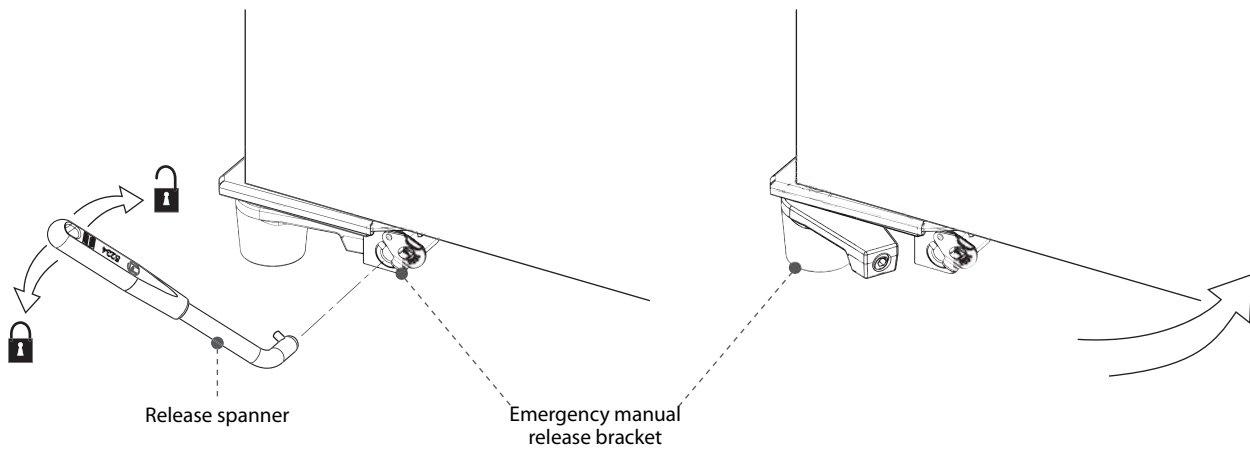

Pic. 30

Actuator releasing for manual operations of the gate without the emergency manual release bracket

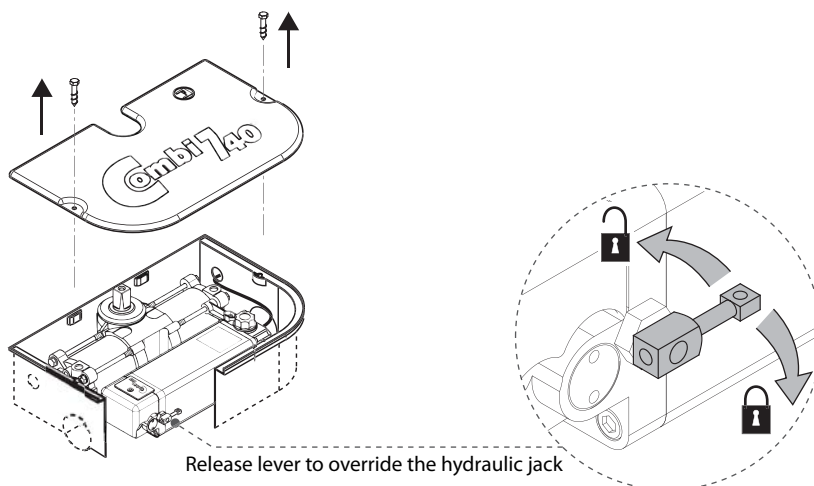

Pic. 31

English



MAINTENANCE RECORD
hand over to the end user of the installation

Installation address:		Maintainer:	Date:
Installation type: Sliding gate <input type="checkbox"/> Folding door <input type="checkbox"/> Swinging gate <input checked="" type="checkbox"/> Road barrier <input type="checkbox"/> Over-head door <input type="checkbox"/> Bollard <input type="checkbox"/> Lateral folding door <input type="checkbox"/> <input type="checkbox"/>		Operator model:	Quantity of models installed:
		Dimensions per gate leaf:	
		Weight per gate leaf:	Installation date:

NOTE WELL: this document must record any ordinary and extraordinary services including installation, maintenance, repairs and replacements to be made only by using Fadini original spare parts.
This document, for the data included in it, must be made available to authorized inspectors/officers, and a copy of it must be handed over the end user/s.

The installer/maintainer are liable for the functionalities and safety features of the installation only if maintenance is carried on by qualified technical people appointed by themselves and agreed upon with the end user/s.

N°	Service date	Service description	Technical maintainer	End user/s
1				
2				
3				
4				
5				
6				

Stamp and signature
installation technician/maintainer

Signed for acceptance
end user
buyer

hand over to the end user of the installation



TECHNICAL DATA

TWO-PHASE, CLASS H ELECTRIC MOTOR

Power output	0,18 kW (0,25 HP)
Absorbed power	250 W
Frequency	50 Hz
Supply voltage	230 Vac
Absorbed power	1,2 A
Capacitor	12,5 µF
Motor rotation speed	1.350 rpm
Intermittent service	S3

PERFORMANCE (shaft rotation angle 110°)

Frequency of use	intensive
Duty cycle	opening ~ 23 s
	stop 15 s
	closing ~ 23 s
	stop 15 s
Time of one complete cycle	~ 76 s
Complete cycles	
opening-stop-closing-stop	N° 45 / hour

DOUBLE STROKE JACK AND OIL-HYDRAULIC PUMP

Pump flow rate - P3	0,85 l/min
Working temperature	-20 °C +80 °C [A]
Oil type	FADINI Oil - Code 708L
Shaft rotation	110° - 175°
Torque	250 - 400 Nm
Piston diameter	75 mm
Piston stroke	52 mm
Weight with foundation box	27 kg
Complete protection grade	IP 67
Max. weight per gate leaf	700 kg
Max. length per gate leaf	4 m
Overall dimensions (L x W x H)	470x300x140 mm

PERFORMANCE (shaft rotation angle 175°)

Frequency of use	intensive
Duty cycle	opening ~ 28 s
	stop 20 s
	closing ~ 28 s
	stop 20 s
Time of one complete cycle	~ 96 s
Complete cycles	
opening-stop-closing-stop	N° 40 / hour

[A]: -40 °C with optional special accessories (Helios 29 - general catalogue ref.).

COMBI 740 DIMENSIONS

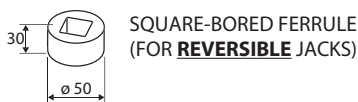

SQUARE-BORED FERRULE
(FOR **REVERSIBLE** JACKS)

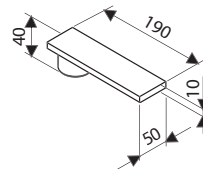

SUPPORT PLATE
WITH SQUARE-BORED FERRULE
(FOR **REVERSIBLE** JACKS)

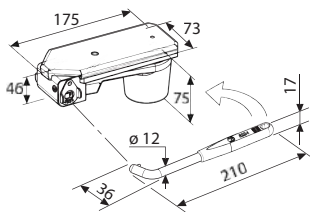

EMERGENCY MANUAL RELEASE WITH SQUARE-BORED FERRULE,
SPANNER AND PLATE TO WELD
(FOR **HYDRAULIC LOCKING** JACKS)

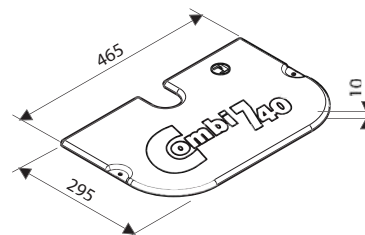

ALUMINIUM COVER
FOR FOUNDATION BOX

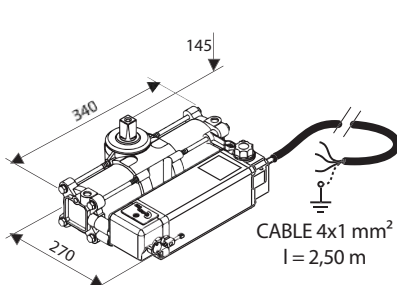

COMBI 740 - 110°

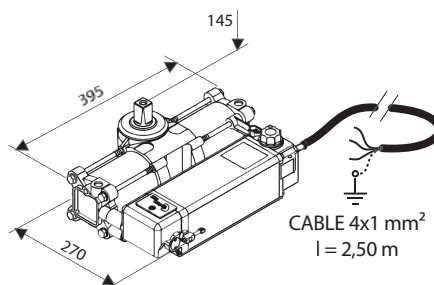

COMBI 740 - 175°

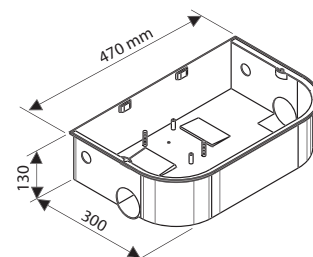

FOUNDATION BOX
(ZINC-COATED OR STAINLESS STEEL)

