

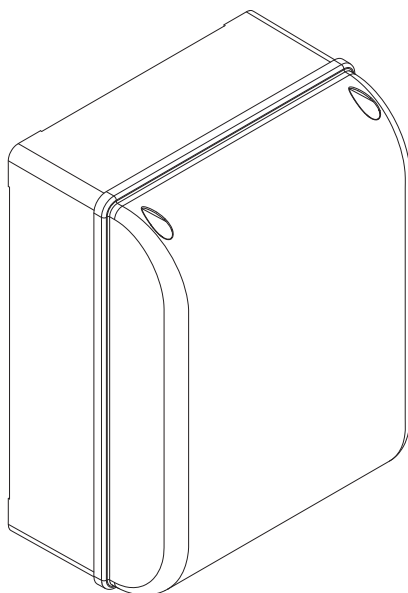

**CONTROL PANEL  
FOR 24 V GEARMOTORS**

FA01261-EN



**ZL60**

**INSTALLATION MANUAL**

## IMPORTANT SAFETY INSTRUCTIONS WHEN INSTALLING



△ Follow all of these instructions as improper installation may lead to be hazardous to people.

Before continuing, also read the general precautions for users.

This control panel is expressly designed to be assembled to partly-completed machinery or equipment so as to build machinery as regulated by European Directive 2006/42/EC. The final installation must conform to Directive 2006/42/EC and to any harmonized reference standards. Given these considerations, all operations provided in this manual must be performed by skilled, qualified staff. • This product should only be used for the purpose for which it was explicitly designed. Any other use is dangerous. CAME S.p.A. is not liable for any damage caused by improper, wrongful and unreasonable use. • Before installing the control panel, make sure that the guided part is in proper mechanical order, that it opens and closes properly and that it is balanced - otherwise, do not continue until you have first complied with all safety provisions. • Make sure that people cannot be entrapped between the guided and fixed parts, when the guided part is set in motion. • The control panel cannot automate any guided part that includes a pedestrian gate, unless the latter can be enabled only when the pedestrian gate is secured. • Make sure the fastening points and the anchoring surface are solid and protected from impacts. Only use suitable nuts, bolts, dowels, and so on. • Laying the cables, installation and testing must follow state-of-the-art procedures as dictated by applicable standards and laws. • Check that the temperature ranges given and those of the location match. • Demarcate the entire site to prevent unauthorized personnel to enter; especially children and minors. • Use proper means of protection to prevent any mechanical hazards from people caught in the movement of the automated operator. Any residual risks must be highlighted by affixing pictograms, in clear view. These must then be explained to the end user of the machinery. • Fit, in plain sight, the machine's ID plate when the installation is complete. • All command and control devices must be fitted so that they are clearly visible, at a proper safety distance from the maneuvering guided-part and where they cannot be reached through said guided part. • Unless the key-operation is functioning (e.g.: Keypad selector, key-switch selector, transponder selector, and so on), any maintained-action control devices must be installed at least 1.5 m from the ground and out of reach from unauthorized users • The manufacturer declines any liability for using non-original products. In which case the warranty will cease to be effective. • All maintained-action switches that are connected to the control panel must be positioned so that the maneuvering area is completely visible from the switches, yet far enough away from any moving parts. • Make sure that the operator has been properly adjusted and that the associated safety and protection devices, if installed, and the manual release, are working properly • If the power-supply cable is damaged, it must be immediately replaced by the manufacturer or by an authorized technical assistance center, or in any case, by qualified staff, to prevent any risk. • During all phases of the installation make sure you have cut off the mains power source. • The electrical cables must run through corresponding tubes or conduits to ensure suitable protection against mechanical damage and they must not come into contact with parts that could heat up during use. • Make sure you have set up a suitable dual pole cut off device along the power supply that is compliant with the installation rules. It should completely cut off the power supply according to category III surcharge conditions.

- Store this manual inside the technical folder, along with the installation manuals of the other devices in the system. Remember to hand over to the end users all the operating manuals of the products that make up the final machinery.

## KEY

-  This symbol shows which parts to read carefully.
-  This symbol shows which parts describe safety issues.
-  This symbol shows which parts to tell users about.

**The measurements, unless otherwise stated, are in millimeters.**

## DESCRIPTION

Control panel for one or two-leaf swing gates with functions set by Dip-switches and adjusted by trimmers.

The control panel is set up for:

- connecting the RGP1 module for reducing energy consumption;
- connecting the RLB card for emergency operation and battery-recharging;

All connections and links are rapid-fuse protected.

### Intended use

For private homes and apartment buildings.

 Any installation and/or use other than that specified in this manual is forbidden.

### Technical data

Type	ZL60
Protection rating (IP)	54 series
Power supply (V - 50/60 Hz)	230 AC
Motor power supply (V)	24 DC
Stand-by consumption (W)	7 series
Stand-by consumption with the RGP1 (W) module	1.15 series
Maximum power (W)	300 series
Casing material	ABS
Operating temperature (°C)	-20 to +55
Apparatus class	I
Weight (kg)	3.6 series

### Fuses

HD Analog	2 A-F = 230 V
Accessories / board	2 A-F

### Dimensions

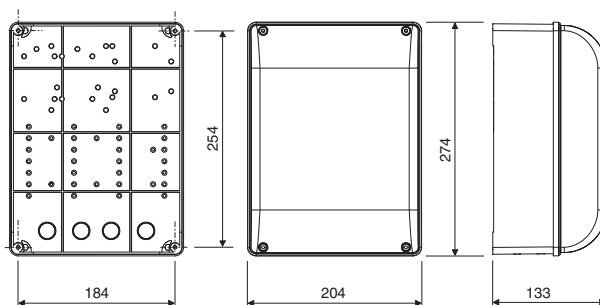

## Description of parts

1. Line fuse
2. Power supply terminals
3. Transformer terminal
4. Transformer
5. RGP1 module terminal
6. Trimmer
7. Programming button
8. DIP-SWITCH
9. Alert LED
10. AF card connector
11. Antenna terminals
12. Safety-device terminals
13. R800 card connector
14. Control-device terminals
15. Keypad selector terminal
16. Gearmotors terminals with encoder
17. Accessories/card fuse
18. Power supply to accessories terminal

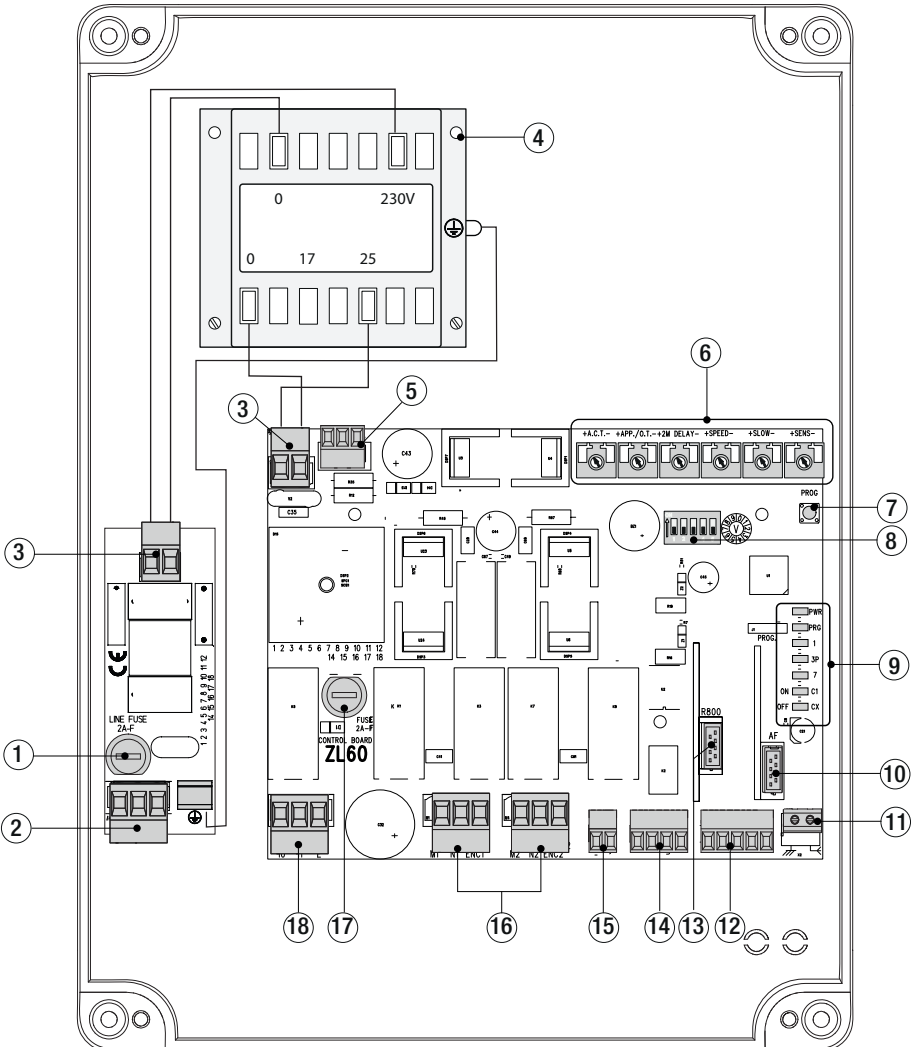

## GENERAL INSTRUCTIONS FOR INSTALLING

- △ Only skilled, qualified staff must install this product in full compliance with the law in force.
- △ Caution! Before working on the control panel, cut off the mains power supply and remove any batteries.

### Cable types and minimum thicknesses

Connection	cable length	
	< 20 m	20 < 30 m
Input voltage for 230 V AC control board (1P+N+PE)	3G x 1.5 mm <sup>2</sup>	3G x 2.5 mm <sup>2</sup>
Signalling devices	2 x 0.5 mm <sup>2</sup>	
Command and control devices	2 x 0.5 mm <sup>2</sup>	
Safety devices (photocells)	(TX = 2 x 0.5 mm <sup>2</sup> ) (RX = 4 x 0.5 mm <sup>2</sup> )	

📖 When operating at 230 V and outdoors, use H05RN-F-type cables that are 60245 IEC 57 (IEC) compliant; whereas indoors, use H05VV-F-type cables that are 60227 IEC 53 (IEC) compliant. For power supplies up to 48 V, you can use FROR 20-22 II-type cables that comply with EN 50267-2-1 (CEI).



📖 To connect the antenna, use the RG58 (we suggest up to 5 m).

📖 If cable lengths differ from those specified in the table, establish the cable sections depending on the actual power draw of the connected devices and according to the provisions of regulation CEI EN 60204-1.

📖 For multiple, sequential loads along the same line, the dimensions on the table need to be recalculated according to the actual power draw and distances. For connecting products that are not contemplated in this manual, see the literature accompanying said products

## INSTALLING

### Fastening the control panel

- 1 Fasten the control panel in a protected area; use rounded cross head screws with maximum 6 mm diameter.
  - 2 Perforate the punched holes.
-  The holes have different diameters: 23, 29 and 37 mm.
-  Be careful not to damage the control board inside the control panel.
- 3 Enter the cable gland with the corrugated tubes for threading the electrical cables.

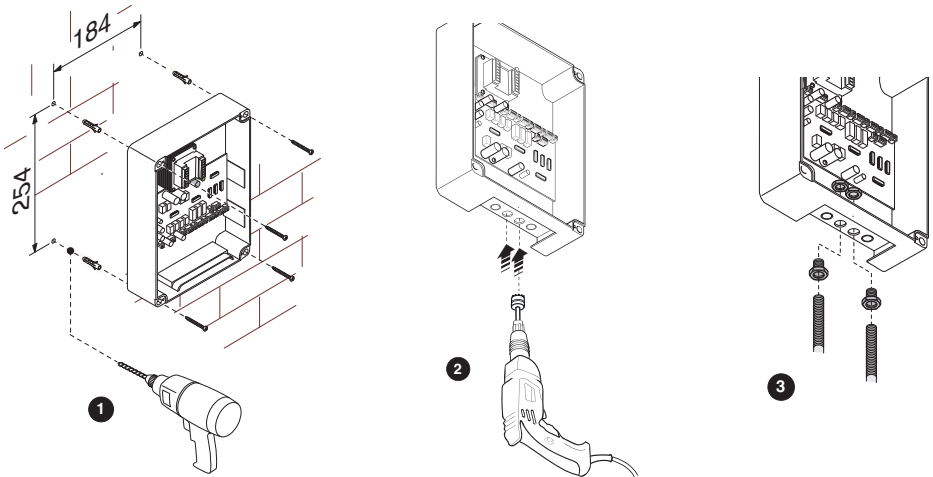

## ELECTRICAL CONNECTIONS AND PROGRAMMING

### Input voltage

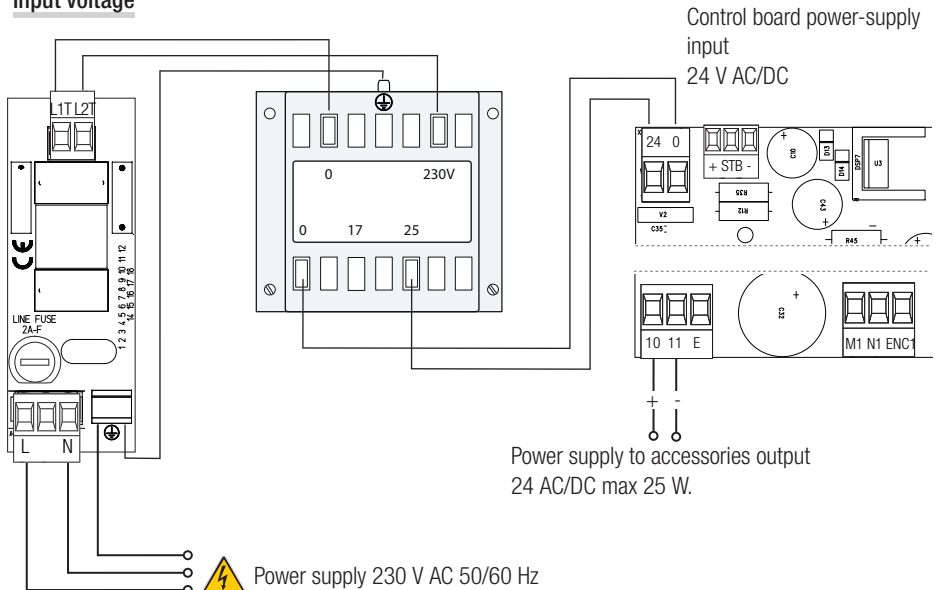

## Connecting the gearmotor to the Encoder

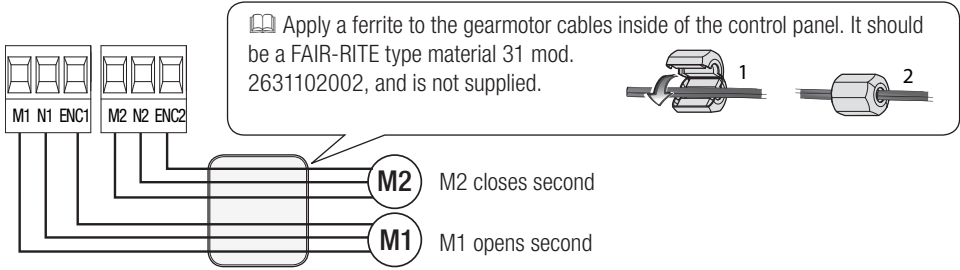

## Warning device

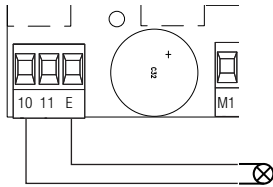

Output for connecting either flashing or cycle light.  
(Contact rated for: 24 V AC/DC - 25 W max).

## Command and control devices

⚠ CAUTION! YOU MUST CUT OFF THE MAINS POWER SUPPLY and remove the batteries, if present, before fitting any plug-in card (such as AF, R800).

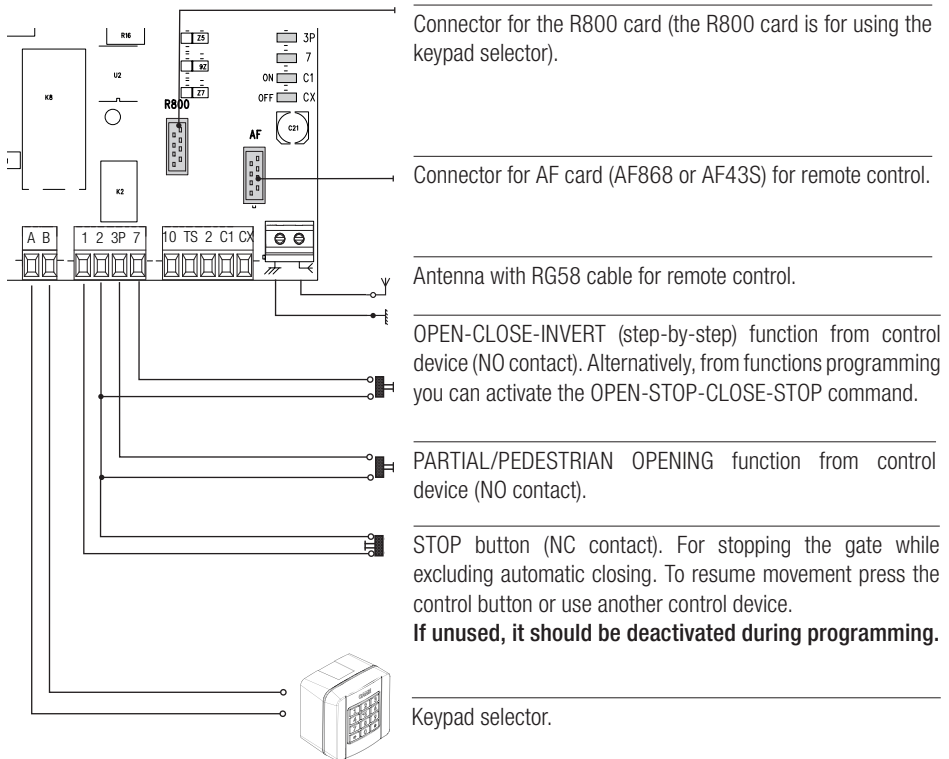



## Safety devices

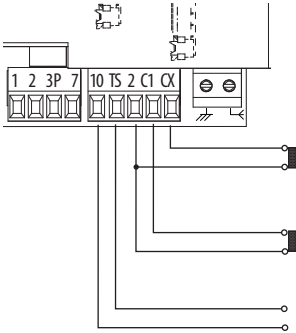

Photocells connection (NC contact), see the functions programming section.

Reopening during closing photocells connection (NC contact) see functions programming.

Photocells safety connection (services test)

### Photocells

Configure contact C1 or CX (NC), input for safety devices such as photocells. See functions programming of input C1 or CX in:

- **C1** reopening while closing. While the gate leaves are closing, opening the contact causes the inversion of movement until they are completely open;
- **CX** partial stop, gate leaves stop if they are moving, triggering the automatic closing time; if the automatic closing time is enabled);
- **CX** obstruction wait, gate leaves stop is they are moving. They resume movement once the obstruction is removed.

**If unused, contacts CX and C1 should be deactivated during programming.**

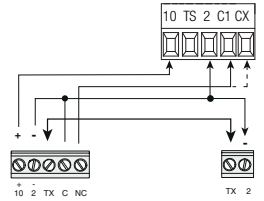

### Connecting the safety devices (i.e. the safety test)

At each opening and closing command, the control board checks the efficacy of the safety devices (such as photocells).

Any anomalies will inhibit all commands.

Enable this function when programming.

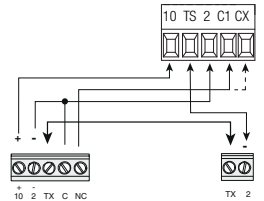

## FUNCTIONS PROGRAMMING

### ⚠ When programming, the operator needs to be in stop mode.

When programming is finished, set all Dip-switches to OFF.

You can save up to 25 users.

Use the Dip-switch to select the function if the LED is lit, the function is enabled. Whereas if the LED is off, the function is disabled.

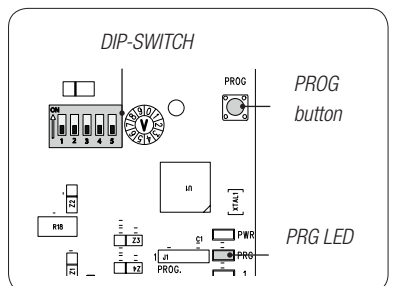

## Functions menu

 **Start programming by first running the following functions: Motor type, Number of motors, TOTAL STOP and self-learning.**

### DIP-SWITCH Description of functions



#### Motor type

By default, the control panel controls OPP001 and FTL20DGC-series gearmotors.

For controlling OPS001, BXL04AGS-series gearmotors.

select the DIP-switches as shown and press the PROG button on the control board. The LED stays lit and the buzzer sounds once.

To return to the default setting, press PROG again. The LED flashes and the buzzer sounds off twice.



#### Number of motors

By default, two motors are configured.

To configure a single motor:

select the DIP-switches as shown and press the PROG button on the control board. The LED stays lit and the buzzer sounds once.

To return to the default setting, press PROG again. The LED flashes and the buzzer sounds off twice.



#### TOTAL STOP from button (contact 1-2)

By default, the feature is enabled.

To disable it:

select the DIP-switches as shown and press the PROG button on the control board. The LED flashes and the buzzer sounds off twice.

To return to the default setting, press PROG again. The LED stays lit and the buzzer sounds once.



#### Self-learning of the gate travel (see Self-learning paragraph)

Select the DIP-switches as shown and press the PROG button on the control board.

The operator will perform a series of maneuvers to establish the limit-switch points. To establish the slow-down starting points - when opening and closing - press PROG when the gate leaves reach the desired position.

During calibration the PRG LED flashes. Once the calibration is done the buzzer sounds off once.

If the calibration is not successful, the LED flashes quickly and the buzzer sounds off seven times.

You can interrupt the gate travel's self-learning operation by pressing the STOP button (if enabled).



#### Reopening during closing (contact 2-C1)

By default, the feature is disabled.

To enable it:

select the DIP-switches as shown and press the PROG button on the control board. The LED stays lit and the buzzer sounds once.

To return to the default setting, press PROG again. The LED flashes and the buzzer sounds off twice.



#### Input on contact 2-CX

By default, the feature is disabled.

To enable it:

select the DIP-switches as shown and press the PROG button on the control board. The LED stays lit and the buzzer sounds once.

To return to the default setting, press PROG again. The LED flashes and the buzzer sounds off twice.



#### Partial stop or obstruction wait (contact 2-CX)

By default, the function is set to partial stop.

To enable the obstruction wait:

Select the DIP-switches as shown and press the PROG button on the control board. The LED stays lit and the buzzer sounds once.

To return to the default setting, press PROG again. The LED flashes and the buzzer sounds off twice.



#### OPEN-CLOSE-INVERT or OPEN-STOP-CLOSE-STOP from button (contact 2-7)

By default, the feature is OPEN-CLOSE-INVERT.

To enable it to OPEN-STOP-CLOSE-STOP:

select the DIP-switches as shown and press the PROG button on the control board. The LED stays lit and the buzzer sounds once.

To return to the default setting, press PROG again. The LED flashes and the buzzer sounds off twice.



### Partial opening or pedestrian opening (contact 2-3P)

By default, the opening is set to pedestrian mode.

To enable in partial opening:

select the DIP-switches as shown and press the PROG button on the control board. The LED stays lit and the buzzer sounds once.

To return to the default setting, press PROG again. The LED flashes and the buzzer sounds off twice.



### Obstruction detection with motor stopped

By default, this function is enabled.

To disable it:

select the DIP-switches as shown and press the PROG button on the control board. The LED flashes and the buzzer sounds off twice.

To return to the default setting, press PROG again. The LED stays lit and the buzzer sounds once.



### Excluding the Encoder

By default, the Encoder is enabled.

To disable it:

select the DIP-switches as shown and press the PROG button on the control board. The LED flashes and the buzzer sounds off twice.

To return to the default setting, press PROG again. The LED stays lit and the buzzer sounds off twice.



### Timed slow-downs (with Encoder disabled)

By default, the feature is disabled.

To enable it:

select the DIP-switches as shown and press the PROG button on the control board. The LED stays lit and the buzzer sounds once.

To return to the default setting, press PROG again. The LED flashes and the buzzer sounds off twice.

 Set the APP./O.T. trimmer to maximum and the SENS trimmer to half.

Store the trimmer values according to the procedure indicated.

### Automatic closing

By default, the feature is disabled.

To enable it:

select the DIP-switches as shown and press the PROG button on the control board. The LED stays lit and the buzzer sounds once.

To return to the default setting, press PROG again. The LED flashes and the buzzer sounds off twice.

The wait before the automatic closing starts when the opening limit-switch point is reached - for a time that is settable on the A.C.T. trimmer.

⚠ The automatic closing does not activate if the safety devices are triggered due to obstacle detection, after a total stop or if the power supply is missing.



### Automatic closing after either partial or pedestrian opening

By default, the feature is disabled.

To enable it:

Select the DIP-switches as shown and press the PROG button on the control board. The PRG LED stays lit and the buzzer sounds once.

To return to the default setting, press PROG again. The LED flashes and the buzzer sounds off twice.

⚠ The automatic closing time is permanently set to 10 seconds.



### Pre-flashing (pre-flashing duration: 5 s)

By default, the feature is disabled.

To enable it:

select the DIP-switches as shown and press the PROG button on the control board. The PRG LED stays lit and the buzzer sounds once.

To return to the default setting, press PROG again. The LED flashes and the buzzer sounds off twice.



### Closing thrust

By default, the feature is disabled.

To enable it:

select the DIP-switches as shown and press the PROG button on the control board. The PRG LED stays lit and the buzzer sounds once.

To return to the default setting, press PROG again. The LED flashes and the buzzer sounds off twice.



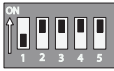

### Saving the trimmer value

Use the trimmers to set the automatic closing time (A.C.T.), the opening and closing latching points, the second motor's closing-delay speed, the slow-down speed (SDS) and the sensitivity (SENS.).

To save the values:

select the DIP-switches as shown and press the PROG button on the control board. The PRG LED stays lit and the buzzer sounds once.

### Services test

By default, the feature is disabled.

To enable it:

Select the DIP-switches as shown and press the PROG button on the control board. The LED stays lit and the buzzer sounds once.

To return to the default setting, press PROG again. The LED flashes and the buzzer sounds off twice.

### Button-activated maintained action

By default, the feature is disabled.

To enable it:

select the DIP-switches as shown and press the PROG button on the control board. The LED stays lit and the buzzer sounds once.

To return to the default setting, press PROG again. The LED flashes and the buzzer sounds off twice.

△ The gate opens and closes when the button is kept pressed.

Opening button connected on 2-3P (contact NO) and closing button connected on 2-7 (contact NO)

All other control devices, even radio-based ones, are excluded.



### Partially open

Select the DIP-switches as shown and press the PROG button for one second. The PRG LED flashes. Within 20 seconds, enter a code from the keypad selector or press any button on the transmitter that you want to save.

Once the saving is finished the PROG LED turns on and the buzzer sounds off once.

If the transmitter has been previously saved or the maximum number of registered users is exceeded the LED flashes quickly and the buzzer sounds off seven times.

### Open only

Select the DIP switches as shown and press the PROG button for one second. The PRG LED flashes. Within 20 seconds, enter a code from the keypad selector or press any button on the transmitter that you want to save.

Once the saving is finished the PROG LED stays on and the buzzer sounds off once.

If the transmitter has been previously saved or the maximum number of registered users is exceeded the LED flashes quickly and the buzzer sounds off seven times.

### OPEN-CLOSE-INVERT

Select the DIP switches as shown and press the PROG button for one second. The PRG LED flashes. Within 20 seconds, enter a code from the keypad selector or press any button on the transmitter that you want to save.

Once the saving is finished the PROG LED stays on and the buzzer sounds off once.

If the code has been previously saved or the maximum number of registered users exceeded, the LED flashes quickly and the buzzer sounds off seven times.

### OPEN-STOP-CLOSE-STOP

Select the DIP switches as shown and press the PROG button for one second. The PRG LED flashes. Within 20 seconds, enter a code from the keypad selector or press any button on the transmitter that you want to save.

Once the saving is finished the PROG LED stays on and the buzzer sounds off once.

If the code has been previously saved or the maximum number of registered users exceeded, the LED flashes quickly and the buzzer sounds off seven times.



### Deleting all users

Select the Dip-switches as shown and press the PROG button for five seconds.

Once deletion is complete, the PRG LED stays lit and buzzer sounds off for one second.

### Resetting parameters

Select the Dip-switches as shown and press the PROG button for five seconds.

Once deletion is complete, the PRG LED stays lit and buzzer sounds off for one second.

This function does not delete any users.



SERVICING UP TO 25 USERS

## Auto-learning of the gate-leaf travel

### With the Encoder enabled (the default setting)

Select the DIPs and press the PROG key on the board as shown in features programming.

The operator will perform a series of maneuvers to establish the starting slow-down and limit-switch points.

- **A** = 25% of the movement area at slowed down speed when opening.
- **B** = 25% of the area of movement at slowed down closing speed.

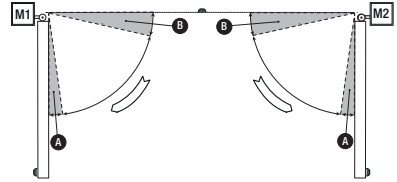

### How to change the opening and closing slow-down points with Encoder enabled

Close the gate leaves.

Start the gate-leaf travel self-learning procedure.

When M2 reaches the desired closing slow-down starting point **B** (10/45 % of the travel), press the PROG button.

Press again the PROG button when M2 reaches the desired opening slow-down starting point **A** (55/90 % of the travel).

Repeat the procedure for M1.

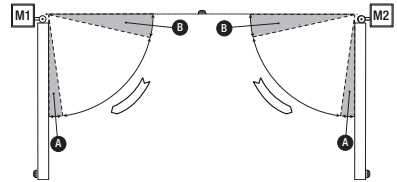

### Timed slow-downs with Encoder disabled

📖 Set the OP TIME trimmer to maximum, set the SENS trimmer to half, save the trimmers' values, disable the Encoder, enable the timed slow-down function.

Start the gate-leaf travel self-learning procedure.

The operator will perform a series of maneuvers to establish the starting slow-down and limit-switch points.

- **A** = 25% of the working time at slowed opening speed.
- **B** = 25% of the working time at slowed closing speed.

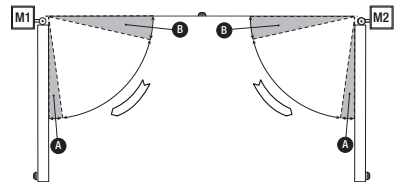

### With Encoders and timed slow-downs disabled

📖 If the **Encoder** and **Slow-down functions** are both disabled, the gate leaves will open or close completely at a constant, limited speed of 50% of the top speed.

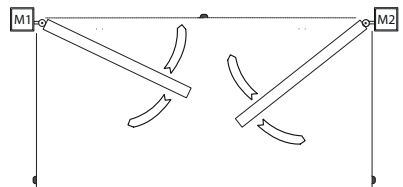

## Adjusting the functions

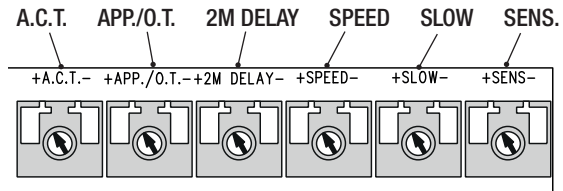
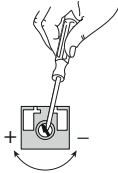

Trimmer	Description of functions
<b>Automatic Closing Time</b>	
<b>A.C.T.</b>	It sets the open gate's waiting time. Once this time elapses, the shutter automatically closes. The waiting time can be adjusted to between 1 and 180 seconds.
<b>Latching point - with Encoder enabled - or operating time - with Encoder disabled.</b>	
<b>APP./O.T.</b>	It adjusts the motors final resting point before the opening and closing limit switches. The starting final resting point is calculated as a percentage of the gate leave's complete travel, from 1% to 10%. When the Encoder is disabled, the trimmer is used to set the operating time from 5 to 120 seconds.
<b>M2 closing delay time</b>	
<b>2M DELAY</b>	After a closing command or after an automatic closing, the leaf of gearmotor (M2) starts with a delay compared to gearmotor (M1) for an adjustable time of between 3 and 25 seconds.
<b>Travel speed</b>	
<b>SPEED</b>	It adjusts the speed of the gearmotors during the maneuvers. The speed can be adjusted from 30% (-) to 100% (+). When the Encoder and the timed slow-downs are disabled, the top speed is 50%.
<b>Slow-down speed</b>	
<b>SLOW</b>	It adjusts the gearmotors' speed when slowing down. The speed may be adjusted from 30% (-) to 60% (+) of the maximum speed. If the slow down speed is greater than the travel speed, the travel speed is automatically limited.
<b>Sensitivity</b>	
<b>SENS.</b>	It adjusts the obstruction detection sensitivity during the gate movement. Minimum sensitivity (-) or maximum sensitivity (+).

After adjusting the trimmers, select the DIPs and press the PROG key on the board as shown in functions programming section.

### Alert LED

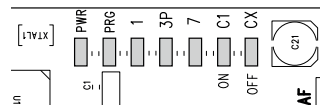

LEDs	Description
<b>PWR (Green)</b>	It warns about the voltage running through the control control board.
<b>PRG (Red)</b>	It warns about the functions' programming phases, the automatic closing waiting time and of any errors/malfunctions.
<b>1 (Yellow)</b>	It warns that contact 1-2 (NC) is open (STOP button).
<b>3P (Yellow)</b>	It warns that contact 2-3P (NO) is closed (partial opening button).
<b>7 (Yellow)</b>	It warns that contact 2-7 (NO) is closed (command button).
<b>C1/ON (Yellow)</b>	It warns that contact 2-C1 (NC) is open (photocells) / Function enabled.
<b>CX/OFF (Yellow)</b>	It warns that contact 2-CX (NC) is open (photocells) / Function disabled.

## FINAL OPERATIONS

### Fastening the cover

Once finished with the electrical connections and powering up, fit the cover and secure it using the supplied screws.

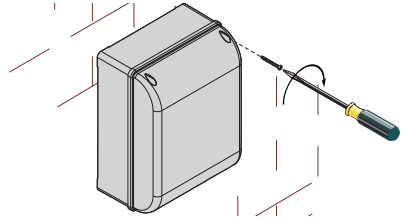

## TROUBLESHOOTING

ALERTS	POSSIBLE CAUSES	FIXES
THE PROG LED flashes and the buzzer sounds every 5 s	<ul style="list-style-type: none"><li>• The control board does not work</li></ul>	<ul style="list-style-type: none"><li>• Call for assistance</li></ul>
The PROG LED flashes and the buzzer sounds off seven time	<ul style="list-style-type: none"><li>• Self-learning error</li></ul>	<ul style="list-style-type: none"><li>• Check that the gearmotor and encoder are properly connected</li></ul>
	<ul style="list-style-type: none"><li>• Encoder error</li></ul>	<ul style="list-style-type: none"><li>• Call for assistance</li></ul>
	<ul style="list-style-type: none"><li>• Services test error</li></ul>	<ul style="list-style-type: none"><li>• Check that the photocells are connected and working properly</li></ul>
	<ul style="list-style-type: none"><li>• Operating time error</li></ul>	<ul style="list-style-type: none"><li>• Check that the gearmotors and the operating-time setting are in order</li></ul>
	<ul style="list-style-type: none"><li>• Maximum number of obstructions consecutively detected (max 5)</li></ul>	<ul style="list-style-type: none"><li>• Remove obstruction</li></ul>
	<ul style="list-style-type: none"><li>• Error during the resetting of parameters or deleting of users</li></ul>	<ul style="list-style-type: none"><li>• The PROG key must be pressed for over 5 seconds</li></ul>
<ul style="list-style-type: none"><li>• User already saved or maximum number of registered users exceeded</li></ul>	<ul style="list-style-type: none"><li>• Check whether the user is, in fact, saved</li></ul>	

## DISMANTLING AND DISPOSAL

Decommissioning and dismantling - always check the current applicable law before continuing. The packaging materials (cardboard, plastic, and so on) should be disposed of as solid household waste, and simply separated from other waste for recycling.

Whereas other components (control boards, batteries, transmitters, and so on) may contain hazardous pollutants. These must therefore be disposed of by authorized, certified professional services.

**DISPOSE OF RESPONSIBLY!**



Fabbricante / Manufacturer / Hersteller / Fabricant / Fabricante / Fabricante  
/ Wytwórca / Fabrikant

**Came S.p.a.**

Indirizzo / address / adresse / adresse / dirección / endereço / adres / adres  
Via Martiri della Libertà 15 - 31030 Dosson di Casier, Treviso - Italy



DICHIARAZIONE CHE IL QUADRO COMANDO PER MOTORIDRATORI A 24 V / DECLARES THAT THE CONTROL PANEL FOR 24 V GEARMOTORS / ERKLÄRT DASS DIE STEUERUNG FÜR 24 V ANTRIEBE / DECLARE QUE LE ARMOIRE DE COMMANDE POUR MOTORÉDUCTEURS 24 V / DECLARA QUE LAS CUADRO DE MANDO PARA MOTORREDUCTORES DE 24 V / DECLARA QUE AS QUADRO DE COMANDO PARA MOTORREDUTORES A 24 V / OŚWIADCZA ZE CENTRALA STERUJĄCA DO NAPĘDÓW ZASŁANYCH NAPĘCIEM 24 V / VERKLAART DAT DE STUURKAST VOOR 24 V-MOTOREN

ZL60

È CONFORME ALLE DISPOSIZIONI DELLE SEGUENTI DIRETTIVE / IT COMPLIES WITH THE PROVISIONS OF THE FOLLOWING DIRECTIVES / DEN VORGABEN DER FOLGENDEN RICHTLINIEN ENTSPRECHEN / IL EST CONFORME AUX DISPOSITIONS DES DIRECTIVES SUIVANTES / CUMPLEN CON LAS DISPOSICIONES DE LAS SIGUIENTES DIRECTIVAS / ESTÁ DE ACORDO COM AS DISPOSICÕES DAS SEGUINTES DIRECTIVAS / SA ZODNIE Z POSTANOVENIAMI NASTEPYJACYCH DYREKTYWY EUROPEJSKICH / VOLDÖEN AAN DE VOORSCHRIFTEN VAN DE VOLGENDE RICHTLIJNEN:

- COMPATIBILITÀ ELETTROMAGNETICA / ELECTROMAGNETIC COMPATIBILITY / ELECTROMAGNETISCHE VERTRÁGLICHKEIT / COMPATIBILITÉ ELECTROMAGNETIQUE / COMPATIBILIDADE ELECTROMAGNETICA / COMPATIBILIDADE ELECTROMAGNETICA / KOMPATYBILNOŚCI ELEKTROMAGNETYCZNEJ / ELECTROMAGNETISCHE COMPATIBILITEIT : 2014/30/EU.

Riferimento norme armonizzate ed altre norme tecniche / Refer to European regulations and other technical regulations / Harmonisierte Bezugsnormen und andere technische Vorgaben / Référence aux normes harmonisées et aux autres normes techniques / Referência normas armonizadas y otras normas técnicas / Referencia de normas armonizadas e outras normas técnicas / Odnozna normy ujednoczone i inne normy techniczne / Geharmoniseerde en andere technische normen waaraan is verwezen.

EN 61000-6-2:2005
EN 61000-6-3:2007+A1:2011
EN 61000-6-4:2007+A11:2011
EN 62233:2008
EN 60335-1:2012+A11:2014
EN 60335-2-103:2015

RISPETTA I REQUISITI ESSENZIALI APPLICATI / MEET THE APPLICABLE ESSENTIAL REQUIREMENTS / DEN WESSENTLICHEN ANGEWANDTEN ANFORDERUNGEN ENTSPRECHEN / RESPECTER LES CONDITIONS REQUISES NECESSAIRES APPLIQUÉES: / CUMPLEN CON LOS REQUISITOS ESSENCIALES APLICADOS / RESPETAM O REQUISITOS ESSENCIAIS APLICADOS: / SPECIFIKACJA PODSTAWOWYCH WYMAGANIE WYKONKI: / VOLDÖEN AAN DE TOEPASSBARE MINIMUM EISEN:

1.1.3; 1.1.5; 1.2.1; 1.2.2; 1.3.1; 1.3.2; 1.3.7; 1.3.8.1; 1.4.1; 1.4.2; 1.5.1; 1.5.6; 1.5.8; 1.5.9; 1.5.9; 1.5.13; 1.6.1; 1.6.3; 1.6.4;

1.7.1; 1.7.2; 1.7.4

PERSONA AUTORIZZATA A COSTITUIRE LA DOCUMENTAZIONE TECNICA PERTINENTE / PERSON AUTHORIZED TO COMPILE THE RELEVANT TECHNICAL INFORMATION / PERSON DE BEVOULMÄCHTIGT IST, DIE RELEVANTEN TECHNISCHEN UNTERLAGEN ZUSAMMENZUSTELLEN / DOCUMENTATION TECHNIQUE SPECIFIQUE D'AUTORISATION A CONSTITUER DE / PERSONA FACULTADA PARA ELABORAR LA DOCUMENTACION TÉCNICA PERTINENTE / PESSOA AUTORIZADA A CONSTITUIR A DOCUMENTAÇÃO TÉCNICA PERTINENTE / OSOBA UPLOWAZNIONA DO ZBIERKOWANIA DOKUMENTACJI TECHNICZNEJ / DEGENE DIE GEMACHTIGT IS DE RELEVANTE TECHNISCHE DOCUMENTEN SAMEN TE STELLEN.

**CAME S.p.a.**

La documentazione tecnica pertinente è stata compilata in conformità all'allegato VIB. / The pertinent technical documentation has been drawn up in compliance with attached document VIB. / Die relevante technische Dokumentation wurde entsprechend der Anlage VIB ausgearbeitet. / La documentation technique spécifique a été compilée conformément à l'annexe IB / La documentación técnica pertinente ha sido redactada en cumplimiento con el anexo VIB. / A documentação técnica pertinente foi preenchida de acordo com o anexo VIB. / Odnozna dokumentacja techniczna została zredagowana zgodnie z załącznikiem VIB. / De technische documentatie terzake is opgesteld in overeenstemming met de bijlage VIB.

CAME S.p.a. si impegna a trasmettere, in risposta a una richiesta adeguatamente motivata dalle autorità nazionali, informazioni pertinenti sulle quasi macchine, e / Came S.p.a., following a duly motivated request from the national authorities, undertakes to provide information related to the quasi machines, and / Die Firma Came S.p.A. verpflichtet sich auf eine angemessen motivierte Anfrage der staatlichen Behörden Informationen über die unvollständigen Maschinen, zu übermitteln, und / Came S.p.a. s'engage à transmettre, en réponse à une demande bien fondée de la part des autorités nationales, les renseignements relatifs aux quasi machines / Came S.p.a. se compromette a transmitir, como respuesta a una solicitud adecuadamente fundamentada por parte de las autoridades nacionales, informaciones relacionadas con las cuasimáquinas / Came S.p.a. compromete-se em transmitir, em resposta a uma solicitação motivada apropriadamente pelas autoridades nacionais, informações pertinentes às partes que compoem máquinas / Came S.p.a. zobowiązuje się do udzielenia informacji dotyczących maszyn niedokończonych na odpowiednio uzasadnioną prośbę, złożoną przez kompetentne organy państwowe / Came S.p.A. verbindt sich anbei an auf mit relevanten onisied verzoek van de nationale autoriteiten de relevante informatie voor de niet voltooide machine te verstrekken.

**VIETA / FORBIDS / VERBIETET / INTERDIT / PROHIBE / PROHIBE / ZABRANIA SIE / VERBIEDT**

La messa in servizio finché la macchina finale in cui deve essere incorporata non è stata dichiarata conforme, ai sensi del capo alla 2006/42/CE, / commissioning of the above mentioned until such machine when the final machine into which they must be incorporated, has been declared compliant, pursuant to 2006/42/CE / die Inbetriebnahme bevor die Endmaschine in die die umschließende Maschine eingebaut wurde, pagbenentfalls gemäß der Richtlinie 2006/42/EU, / la mise en service tant que la machine finale dans laquelle elle doit être incorporée n'a pas été déclarée conforme, en cas échéant, à la norme 2006/42/CE. / la puesta en servicio hasta que la máquina final en la que se incorporará no haya sido declarada de conformidad de acuerdo a la 2006/42/CE / a colocação em funcionamento, até que a máquina final, onde devem ser incorporadas, não for declarada em conformidade, em de acordo com a 2006/42/CE / Uchowanie/urządzenie do czasu, kiedy maszyna, do której ma być wbudowana, nie zostanie oceniona jako zgodna z wymaganiami dyrektywy 2006/42/WE, jeśli taka procedura była konieczna. / Daze in working the statin zolng de eindmachine waarin de niet voltooide machine moet worden ingebouwd in overeenstemming la verklard, indien toepasselijk met de richtlijn 2006/42/EG.

Dosson di Casier (TV)  
31 Gennaio / January / Januar / Janvier / Enero  
/ Janeiro / Styczen / Januari 2018

Legale Rappresentante / Legal Representative / Gesetzlicher Vertreter / Representant Legal / Representante Legal / Reprezentante Legal / Prawny Przedstawiciel / Juridische Vertegenwoordiger

Paolo Menuzzo

Fascicolo tecnico a supporto / Supporting technical dossier / Unterstützung technische Dossier / soutien dossier technique / apoyo expediente técnico / apóir dossier técnico / wspieranie dokumentacji technicznej / ondersteunende technische dossier: 0022L60

**Came s.p.a.**

Via Martiri della Libertà, 15 - 31030 Dosson di Casier - Treviso - Italy - Tel. (+39) 0422 4940 - Fax (+39) 0422 4941  
info@came.it - www.came.com

Cap. Soc. 1.610.000,00 € - C.F. e P.I. 03481280265 - VAT IT 03481280265 - REA TV 275359 - Reg Imp. TV 03481280265

The contents of this manual may change, at any time, and without notice.

**CAME**



**CAME S.P.A.**

Via Martiri Della Libertà, 15  
31030 Dosson di Casier - Treviso - Italy  
tel. (+39) 0422 4940 - fax. (+39) 0422 4941

**CAME.COM**