

## Automatic road barriers

FA01748-EN

CE

EAC

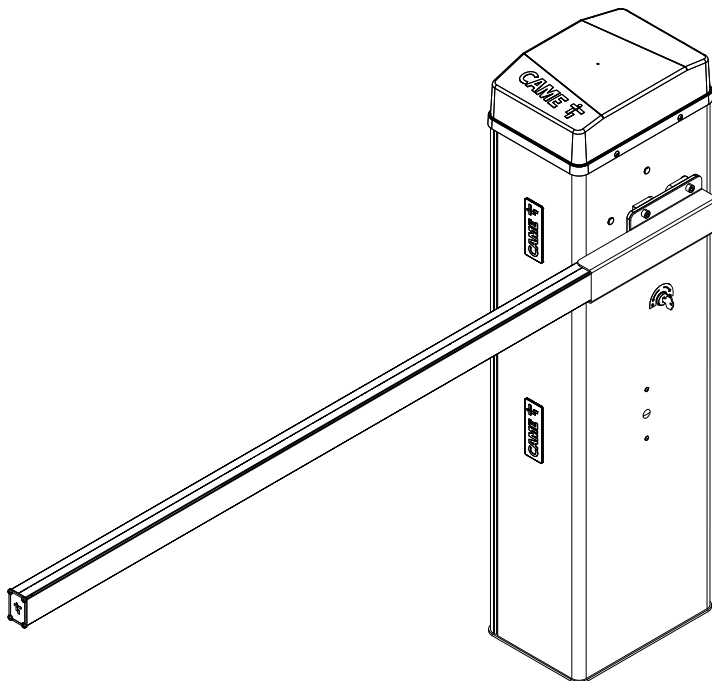

**GLT40AOS**  
**GLT40ACS**

**GLT40ROS**  
**GLT40AX4**

INSTALLATION MANUAL

EN

English



## DEVICE MANUAL RELEASE

⚠ Releasing the device may be dangerous for the user, if the boom fastening has been damaged or if the boom is no longer intact, as the result of an accident or installation error.

In these cases, the tensioned springs no longer guarantee that the boom is balanced. The boom may suddenly rotate when being released.

⚠ Manual release may cause the operator to move in an uncontrolled manner due to a mechanical fault or an imbalance.

📖 With the gearmotor released, the operator does not work.

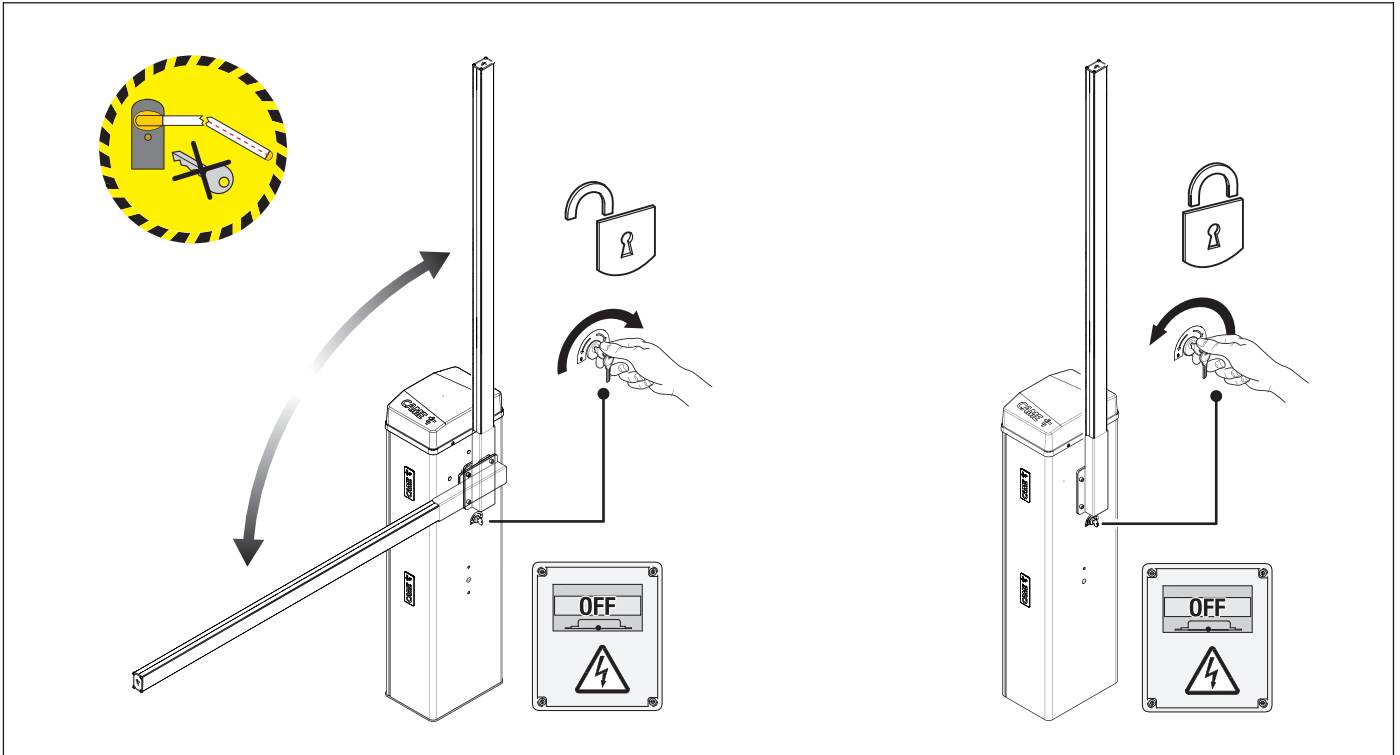

⚠ The balance springs must not be tensioned (boom vertical) when performing maintenance on the barrier.

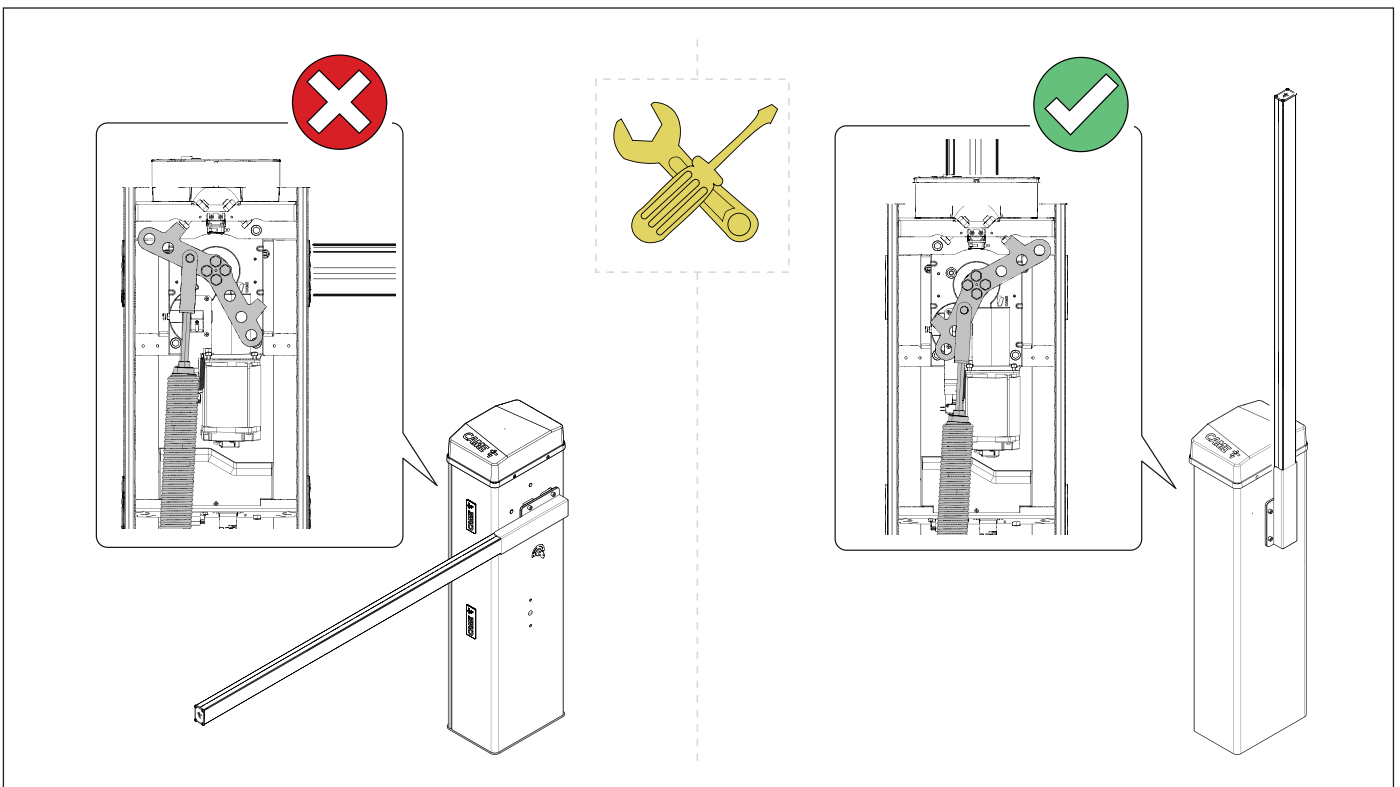

**⚠ Important safety instructions.****⚠ Please follow all of these instructions. Improper installation may cause serious bodily harm.****⚠ Before continuing, please also read the general precautions for users.**

Only use this product for its intended purpose. Any other use is hazardous. • The manufacturer cannot be held liable for any damage caused by improper, unreasonable or erroneous use. • This product is defined by the Machinery Directive (2006/42/EC) as partly completed machinery. • Partly completed machinery means an assembly which is almost machinery but which cannot in itself perform a specific application. • Partly completed machinery is only intended to be incorporated into or assembled with other machinery or other partly completed machinery or equipment thereby forming machinery to which the Machinery Directive (2006/42/EC) applies. • The final installation must comply with the Machinery Directive (2006/42/EC) and the European reference standards in force. • The manufacturer declines any liability for using non-original products, which would also void the warranty. • All operations indicated in this manual must be carried out exclusively by skilled and qualified personnel and in full compliance with the regulations in force. • The device must be installed, wired, connected and tested according to good professional practice, in compliance with the standards and laws in force. • Make sure the mains power supply is disconnected during all installation procedures. • Check that the temperature ranges given are suitable for the installation site. • Make sure that opening the automatic barrier does not constitute a hazard. • Do not install on slopes i.e. any surfaces that are not perfectly level. • Do not install the operator on surfaces that could yield and bend. If necessary, add suitable reinforcements to the anchoring points. • Make sure that no direct jets of water can wet the product at the installation site (sprinklers, water cleaners, etc.). • Make sure you have set up a suitable dual-pole cut-off device along the power supply that is compliant with the installation rules. It should completely cut off the power supply according to category III surcharge conditions. • Demarcate the entire site properly to prevent unauthorised personnel from entering, especially minors. • In case of manual handling, have one person for every 20 kg that needs hoisting; for non-manual handling, use proper hoisting equipment in safe conditions. • When the operator is being fixed in place, it may be unstable and overturn. Be careful and do not lean on it until it is fully fastened in place. • Use suitable protection to prevent any mechanical hazards due to persons loitering within the operating range of the operator. • The electrical cables must pass through special pipes, ducts and cable glands in order to guarantee adequate protection against mechanical damage. • Make sure that the moving mechanical parts are suitably far away from the wiring. • The electrical cables must not touch any parts that may overheat during use (such as the motor and transformer). • All fixed controls must be clearly visible after installation, in a position that allows the guided part to be directly visible, but far away from moving parts. In the case of a hold-to-run control, this must be installed at a minimum height of 1.5 m from the ground and must not be accessible to the public. • If the passage is wider than 3 m, you must use a fixed support for the boom. • If not already present, apply a permanent tag that describes how to use the manual release mechanism close to it. • Make sure that the operator has been properly adjusted and that the safety and protection devices and the manual release are working properly. • Before handing over to the final user, check that the system complies with the harmonised standards and the essential requirements of the Machinery Directive (2006/42/EC). • Any residual risks must be indicated clearly with proper signage affixed in visible areas, and explained to end users. • Put the machine's ID plate in a visible place when the installation is complete. • If the power supply cable is damaged, it must be immediately replaced by the manufacturer or by an authorised technical support service, or in any case, by qualified staff, to prevent any risk. • Keep this manual inside the technical folder along with the manuals of all the other devices used for your automation system. • Make sure to hand over to the end user all the operating manuals of the products that make up the final machinery. • The product, in its original packaging supplied by the manufacturer, must only be transported in a closed environment (railway carriage, containers, closed vehicles). • If the product malfunctions, stop using it and contact customer services at <https://www.came.com/global/en/contact-us> or via the telephone number on the website.

 The manufacture date is provided in the production batch printed on the product label. If necessary, contact us at <https://www.came.com/global/en/contact-us>.

 The general conditions of sale are given in the official CAME price lists.

## Main points of danger for people

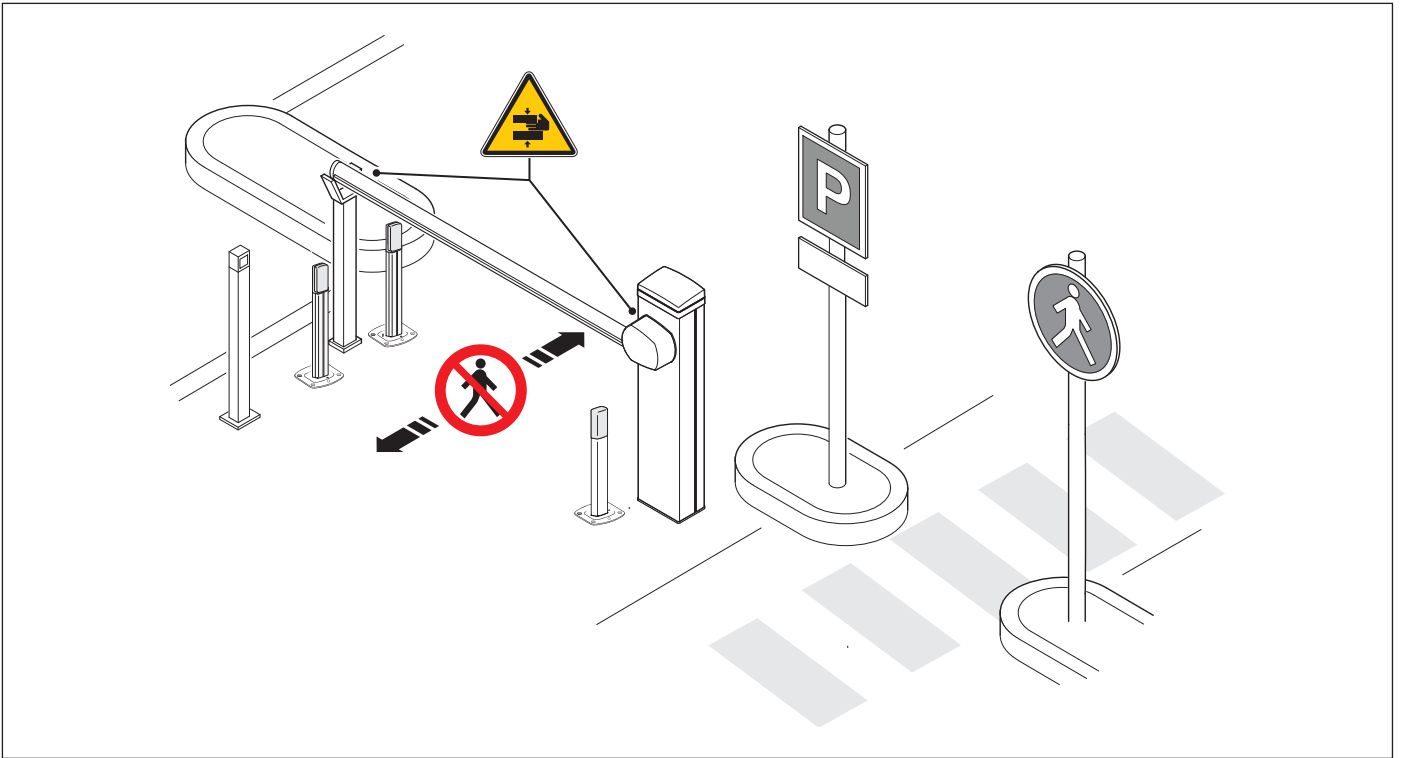

 Risk of trapping hands.

 No transiting.

## DISMANTLING AND DISPOSAL

 CAME S.p.A. employs an Environmental Management System at its premises. This system is certified and compliant with the UNI EN ISO 14001 standard to ensure that the environment is respected and safeguarded. Please continue safeguarding the environment. At CAME we consider it one of the fundamentals of our operating and market strategies. Please follow these brief disposal guidelines:

### DISPOSING OF THE PACKAGING

The packaging materials (cardboard, plastic, etc.) can be disposed of easily as solid urban waste, separated for recycling.

Before dismantling and disposing of the product, please always check the local laws in force.

DISPOSE OF THE PRODUCT RESPONSIBLY.

### DISPOSING OF THE PRODUCT

Our products are made of various materials. Most of these materials (aluminium, plastic, iron and electrical cables) are classified as solid urban waste. They can be separated for recycling and disposed of at authorised waste treatment plants.

Other components (electronic boards, transmitter batteries, etc.) may contain pollutants.

These must be removed and disposed of by an authorised waste disposal and recycling firm.

It is always advisable to check the specific laws that apply in your area.

DISPOSE OF THE PRODUCT RESPONSIBLY.



## PRODUCT DATA AND INFORMATION

### Key

 This symbol shows which parts to read carefully.

 This symbol shows which parts describe safety issues.

 This symbol shows what to tell users.

 The measurements, unless otherwise stated, are in millimetres.

### Description

#### 803BB-0370

GLT40AOS - Automatic barrier with irreversible gearmotor 24 V DC with encoder; painted galvanised steel cabinet; accessories available. Balance spring included.

#### 803BB-0380

GLT40ROS - Automatic barrier with irreversible gearmotor 24 V DC with encoder; painted galvanised steel cabinet; accessories available. Balance spring included.

#### 803BB-0390

GLT40ACS - Automatic barrier with irreversible gearmotor 24 V DC with encoder; custom-RAL painted galvanised steel cabinet; accessories available. Balance spring included.

#### 803BB-0400

GLT40AX4 - Automatic barrier with irreversible gearmotor 24 V DC with encoder; satin-finish AISI 304 steel cabinet; accessories available. Balance spring included.

### Intended use

The ideal solution for access roads with heavy transit flows

 Any installation and/or use other than that specified in this manual is forbidden.

### Usage limitations

MODELS	GLT40AOS	GLT40ROS	GLT40ACS	GLT40AX4
Max. net clearance width (m)	4	4	4	4

### Technical data

MODELS	GLT40AOS	GLT40ROS	GLT40ACS	GLT40AX4
Power supply (V - 50/60 Hz)	220-230 AC	120 AC	220-230 AC	220-230 AC
Maximum current draw (A)	0,8	1,6	0,8	0,8
Motor power supply (V)	24 DC	24 DC	24 DC	24 DC
Standby consumption (W)	7	7	7	7
Power (W)	190	190	190	190
Operating temperature (°C)	-20 ÷ +55 (-40 with item 803XA-0630)	-20 ÷ +55 (-40 with item 803XA-0630)	-20 ÷ +55 (-40 with item 803XA-0630)	-20 ÷ +55 (-40 with item 803XA-0630)
Torque (Nm)	140	140	140	140
Opening time at 90° (s)	2 ÷ 6	2 ÷ 6	2 ÷ 6	2 ÷ 6
Cycles/hour	300	300	300	300
Cycles/day	5400	5400	5400	5400
Protection rating (IP)	54	54	54	54
Insulation class	I	I	I	I
Weight (kg)	56	56	56	56
Storage temperature (°C)*	-20 ÷ +70	-20 ÷ +70	-20 ÷ +70	-20 ÷ +70
Average life (cycles)**	1.500.000	1.500.000	1.500.000	1.500.000

(\*) Before installing the product, keep it at room temperature where it has previously been stored or transported at a very high or very low temperature.

(\*\*) The average product life specified should be understood purely as an indicative estimate. It applies to normal usage conditions and where the product has been installed and maintained in compliance with the instructions provided in the CAME technical manual. The average product life is also affected, including significantly, by other variables such as, but not limited to, climatic and environmental conditions. The average product life should not be confused with the product warranty.

### Fuse table

MODELS	GLT40AOS	GLT40ROS	GLT40ACS	GLT40AX4
Line fuse	1.6 A-F	3.15 A-F	1.6 A-F	1.6 A-F
Accessory fuse	2 A-F	2 A-F	2 A-F	2 A-F
Control board fuse	4 A-F	4 A-F	4 A-F	4 A-F
Motor fuse	10 A-F	10 A-F	10 A-F	10 A-F

## Description of parts

### Barrier

- 1 Cover
- 2 Boom anchoring plate
- 3 Intermediate plate
- 4 Fastening flange
- 5 DIR/DXR photocell holes
- 6 Lock for release
- 7 Cabinet
- 8 Inspection hatch
- 9 Inspection-hatch lock
- 10 Control panel
- 11 Mechanical stop for the boom adjustment
- 12 Lever arm
- 13 Gear motor with encoder
- 14 Power supply terminal board
- 15 Line fuse
- 16 Anchoring plate
- 17 Anchoring bracket
- 18 Boom profile end cap
- 19 Spring anchoring pin
- 20 001G04060 - Molla di bilanciamento Ø 50 mm.
- 21 Released gearmotor safety microswitch

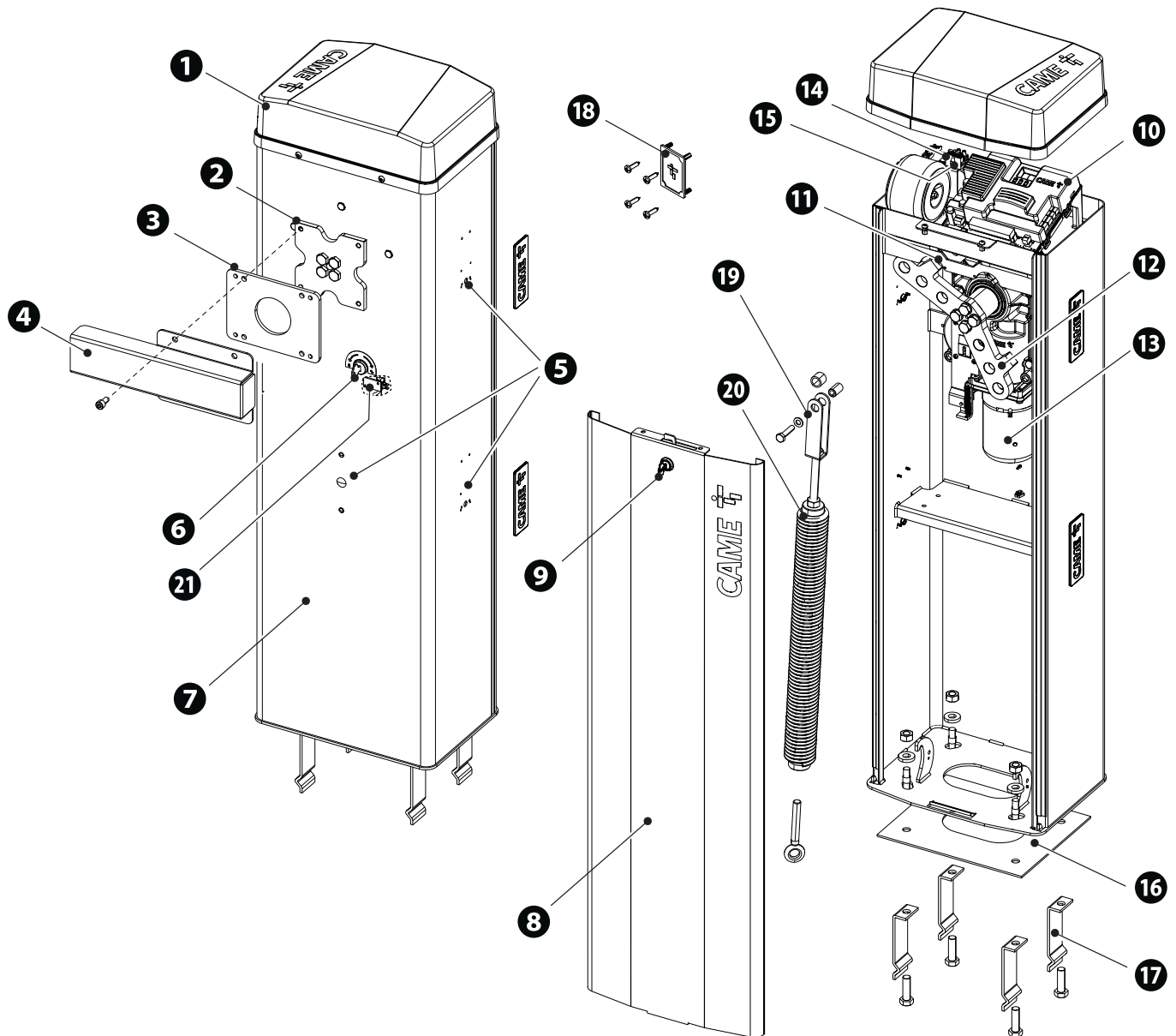

## Control board

- ❶ Programming buttons
- ❷ Terminal board for motor power supply
- ❸ Display
- ❹ Connector for plug-in radio frequency card (AF)
- ❺ Terminal board for connecting the antenna
- ❻ Connector for the R700 or R800 decoding card
- ❼ RSE\_1 connector for RSE card
- ❽ Terminal board for connecting the keypad selector
- ❾ Terminal board for connecting the transponder selector switch
- ❿ Terminal board associated with the RSE\_1 connector for paired, alternate or CRP connection
- ⓫ Terminal board associated with the RSE\_2 connector for CRP connection, IO 485 card or Modbus RTU interface
- ⓬ Terminal board for connecting the safety microswitch with cover open and gearmotor released (NC contact)
- ⓭ RSE\_2 connector for RSE card
- ⓮ Terminal board for connecting control and safety devices
- ⓯ Terminal board for connecting the encoder
- ⓰ Accessories fuse
- ⓱ Control board fuse
- ⓲ Terminal board for power supply to the control board
- ⓳ Motor fuse
- ⓴ Connector for CAME KEY\*
- ⓵ Memory Roll card connector
- ⓶ Terminal board for connecting the warning LED strip

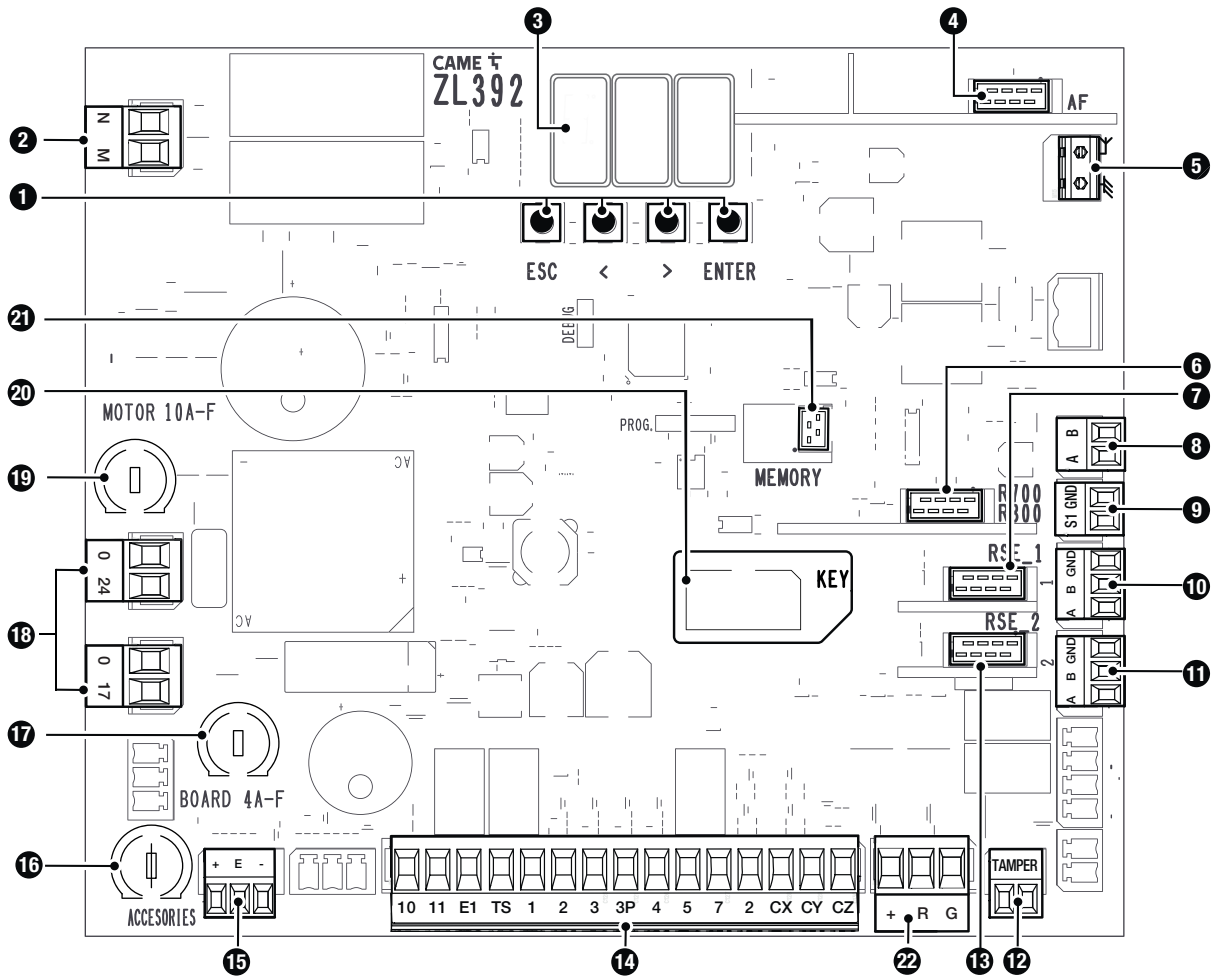

 Remove the card cover before inserting the cards into the connectors.

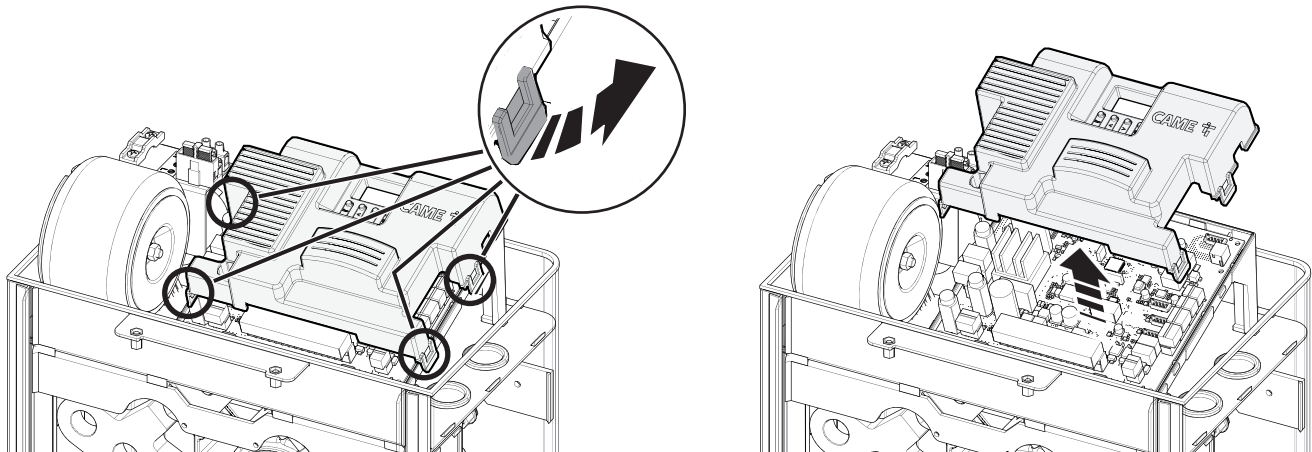

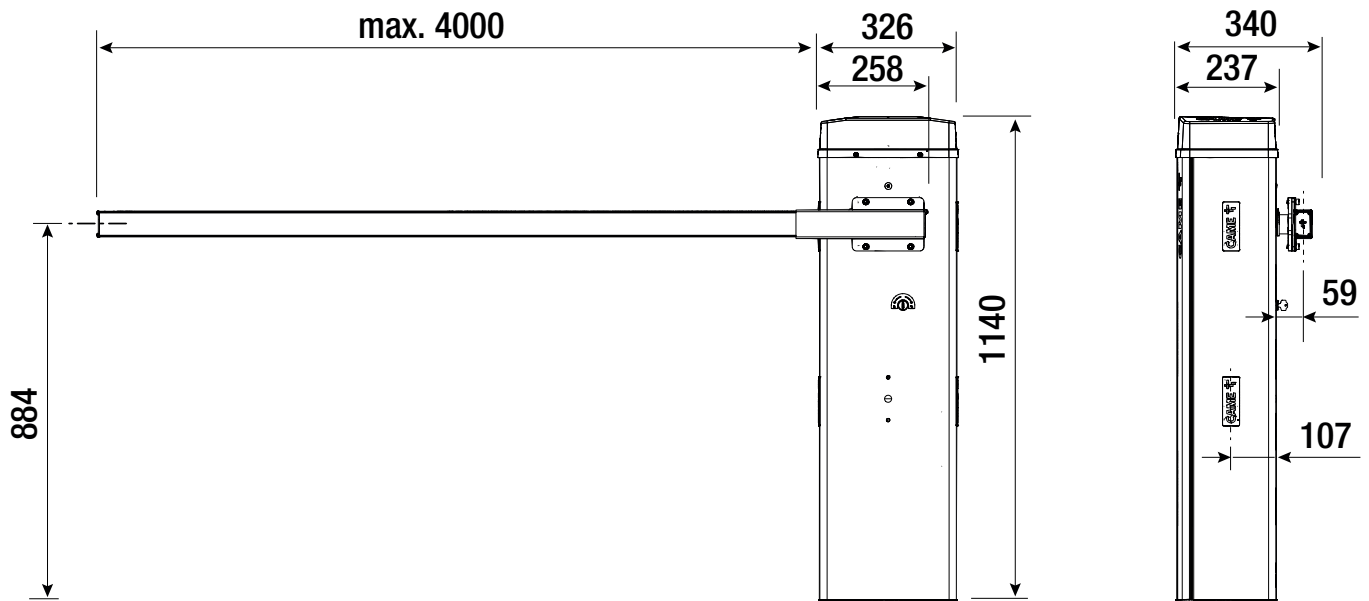

**Cable types and minimum thicknesses**

Cable length (m)	up to 20	from 20 to 30
Power supply 230 V AC	3G x 1.5 mm <sup>2</sup>	3G x 2.5 mm <sup>2</sup>
Power supply 120 V AC	3G x 1.5 mm <sup>2</sup>	3G x 2.5 mm <sup>2</sup>
24 V AC/DC flashing beacon	2 x 1 mm <sup>2</sup>	2 x 1 mm <sup>2</sup>
TX Photocells	2 x 0.5 mm <sup>2</sup>	2 x 0.5 mm <sup>2</sup>
RX photocells	4 x 0.5 mm <sup>2</sup>	4 x 0.5 mm <sup>2</sup>
Command and control devices	*no. x 0.5 mm <sup>2</sup>	*no. x 0.5 mm <sup>2</sup>

\* no. = see product assembly instructions - Warning: the cable cross-section is indicative and varies according to the motor power and cable length.

- To connect the antenna, use RG58 cable (up to 5 m).
- For installation in an outdoor environment, use cables with properties at least equivalent to those of type H05RN-F (with designation 60245 IEC 57).
- For installation in an indoor environment, use cables with properties at least equivalent to those of type H05VV-F (designation to 60227 IEC 53).
- If the cable lengths differ from those specified in the table, define the cable cross-sections according to the actual power draw of the connected devices and in line with regulation CEI EN 60204-1.
- For multiple, sequential loads along the same line, recalculate the values in the table according to the actual power draw and distances. For information on connecting products not covered in this manual, please see the documentation accompanying the products themselves.
- For paired and CRP connection, use a UTP CAT5 cable. Maximum length 1000 metres.

**Wind resistance**

- The table shows the boom wind-load resistance.
- The value relates to the boom only and does not refer to any applicable accessories.
- Resistance class with reference to the EN 13241 standard.

Type	Boom 3.2 m	Boom 4.2 m
Resistance class	3	2
Wind pressure [Pa]	600	350
Maximum wind speed [km/h]	120	90

## INSTALLATION

 The following illustrations are examples only. The space available for fitting the operator and accessories varies depending on the area where it is installed. It is up to the installer to find the most suitable solution.

In case of manual handling, have one person for every 20 kg that needs hoisting; for non-manual handling, use proper hoisting equipment in safe conditions. When the operator is being fixed in place, it may be unstable and overturn. Be careful and do not lean on it until it is fully fastened in place.

### Preliminary operations

 If the flooring does not allow the device to be fastened in a solid and stable way, lay a cement slab. Dig a hole for the foundation frame. Set up the corrugated tubes needed for the wiring coming out of the junction pit.

 The number of tubes depends on the type of system and the accessories that are going to be fitted.

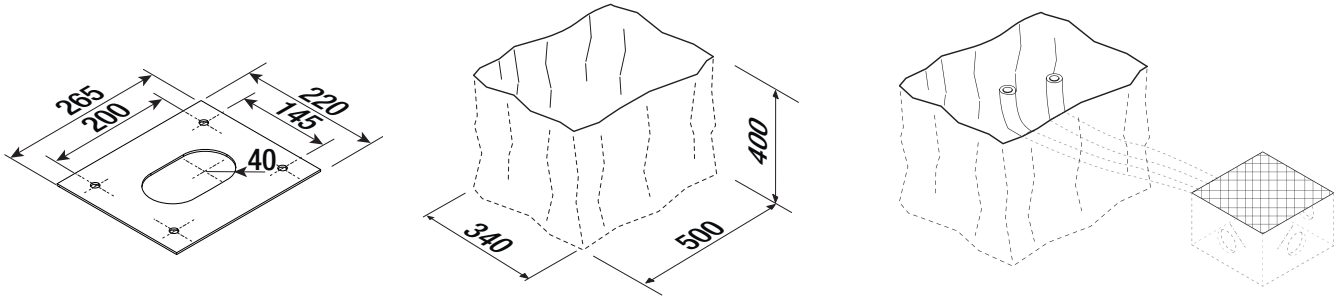

### Laying the anchoring plate

Set up a foundation frame that is larger than the anchoring plate. Fit an iron cage in the foundation frame to reinforce the concrete. Assemble the anchoring braces to the plate.

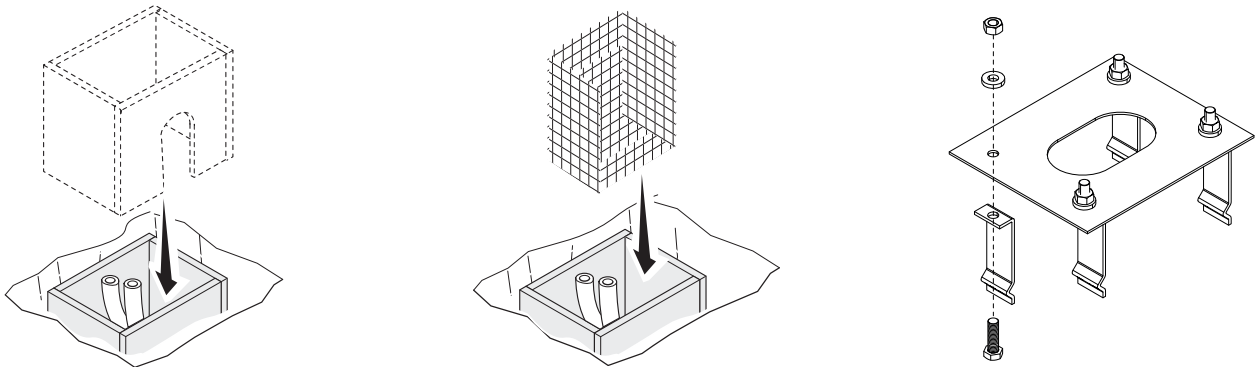

Fit the anchoring plate in the iron cage.

 The tubes must pass through the existing holes.

Cast cement into the foundation frame.

 The plate must be perfectly level and the screw threads completely above surface.

Wait at least 24 hours for the cement to dry.

Remove the foundation frame.

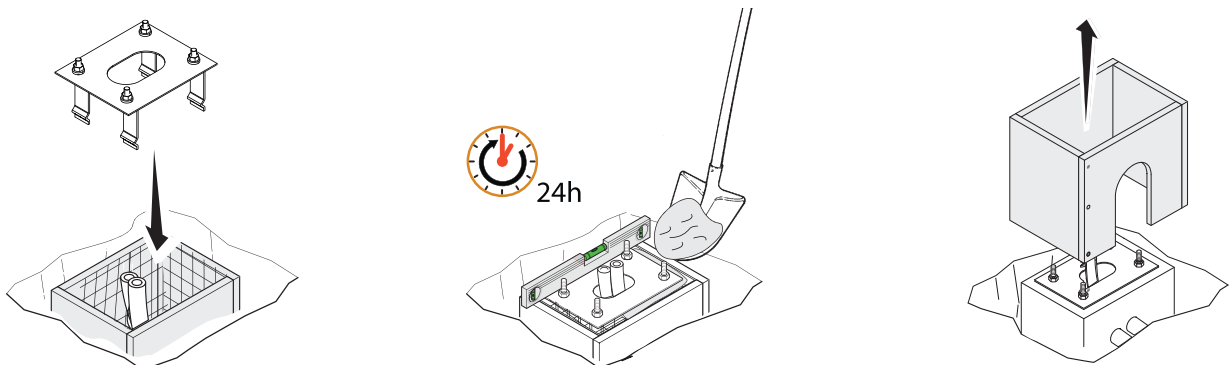

Fill the hole with soil around the concrete block.  
 Remove the nuts from the screws.  
 Thread the electrical cables into the tubes so that they protrude by about 1500 mm.

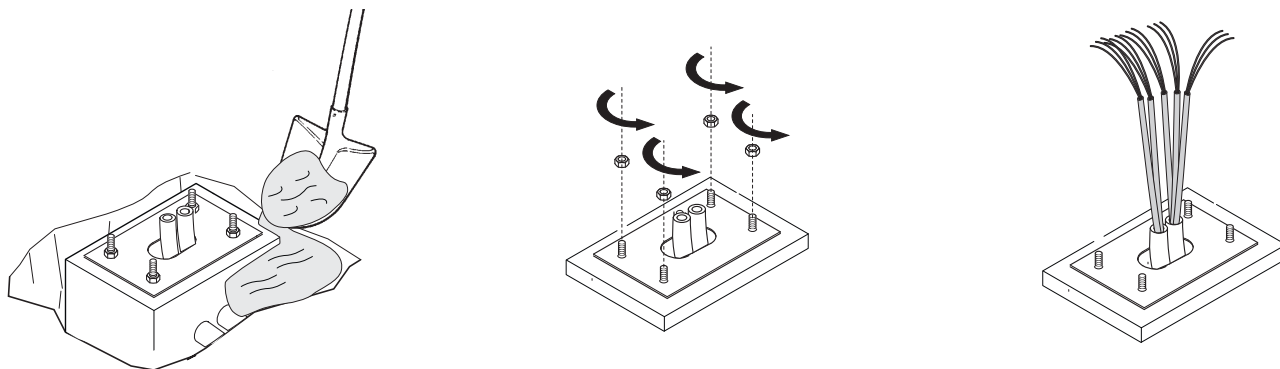

## Preparing the barrier

With the inspection hatch open, the operator does not work.

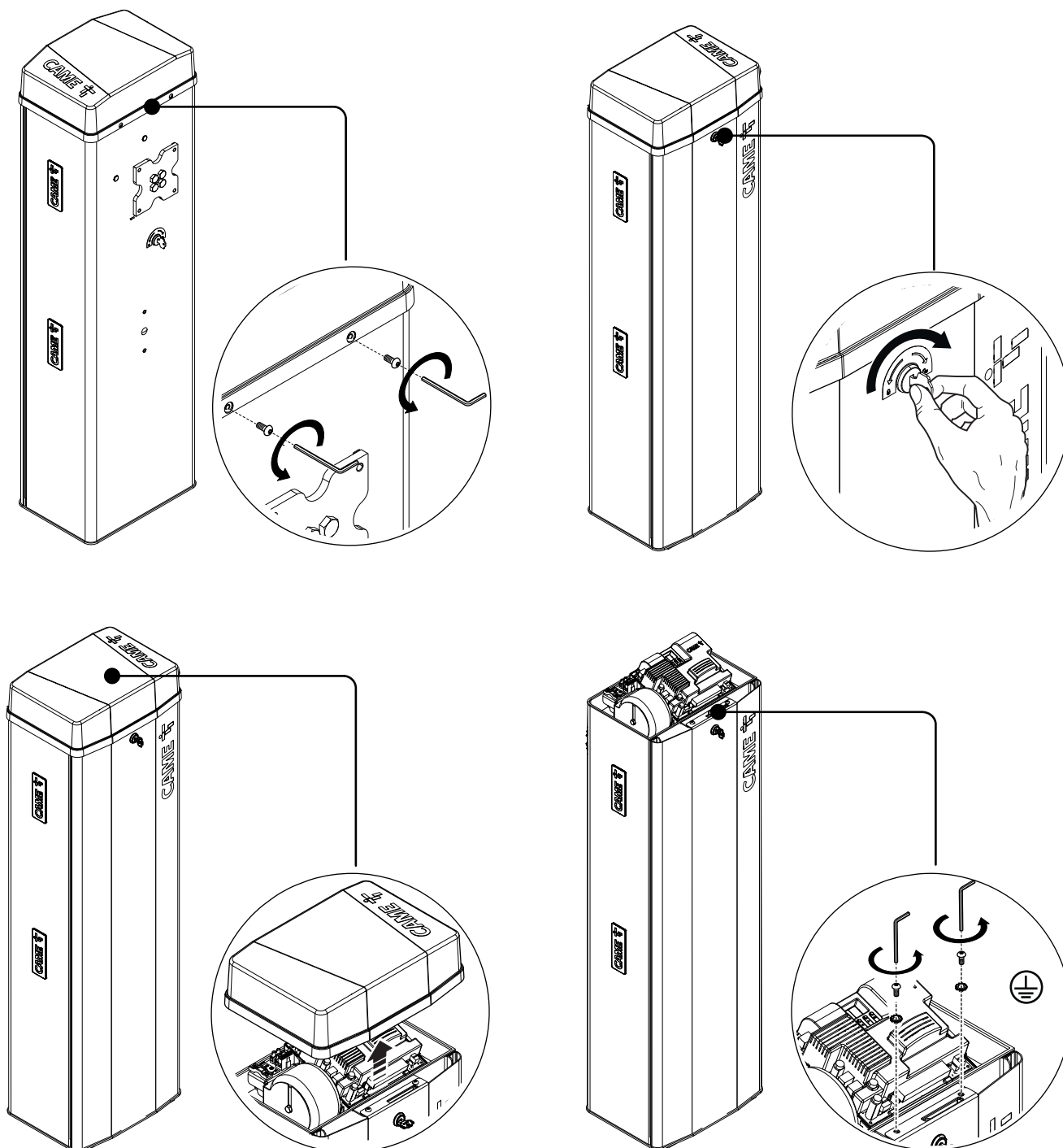

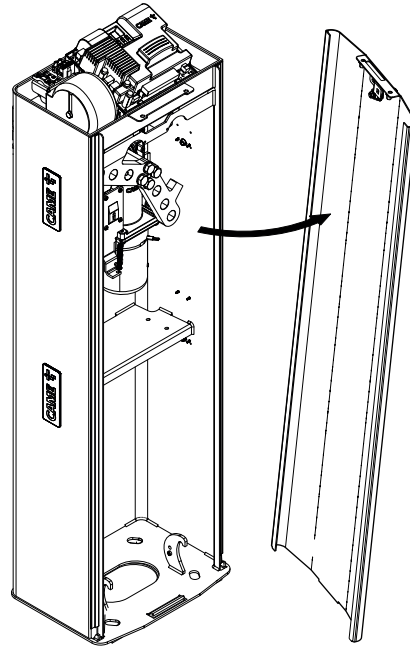
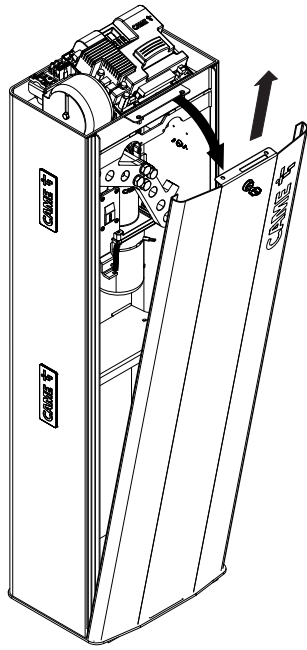

### Fastening the barrier

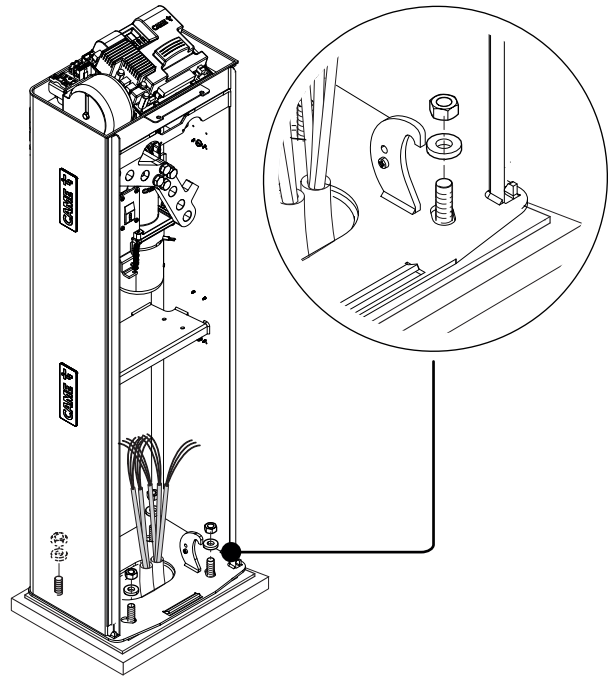
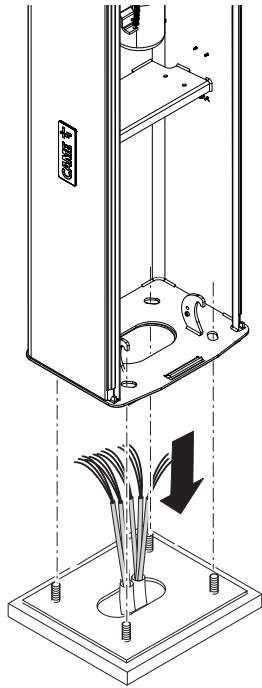



## Changing the boom opening direction

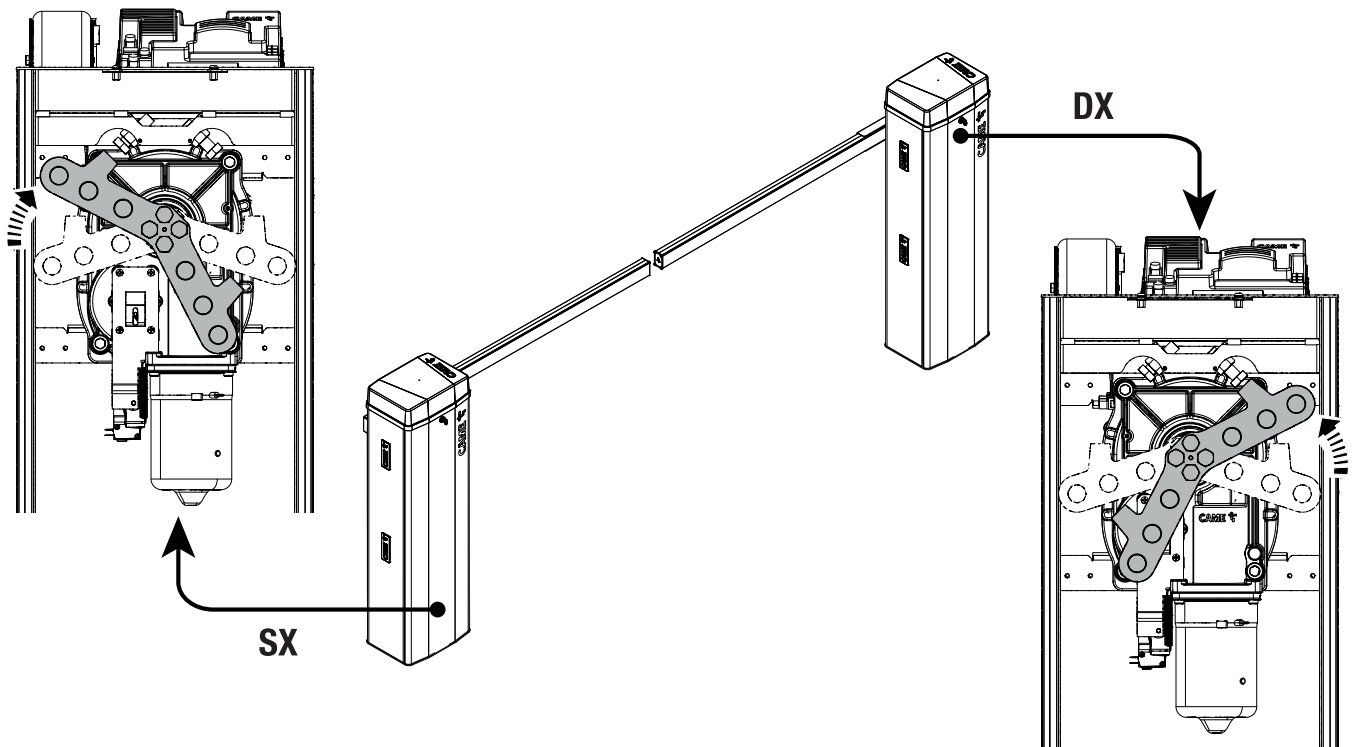

## Boom installation

Fix the flange and the intermediate plate to the anchoring plate with four screws leaving them loose.  
Fit the boom into the fastening flange.

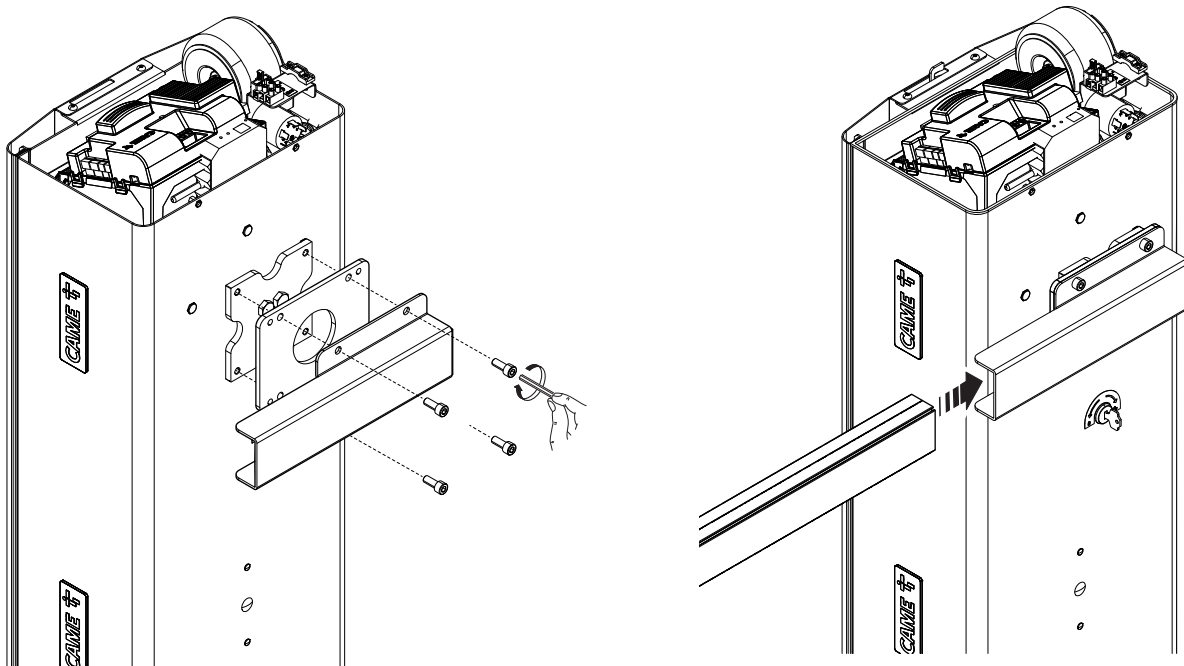



Tighten the screws using a torque wrench and a torque of 20 Nm.

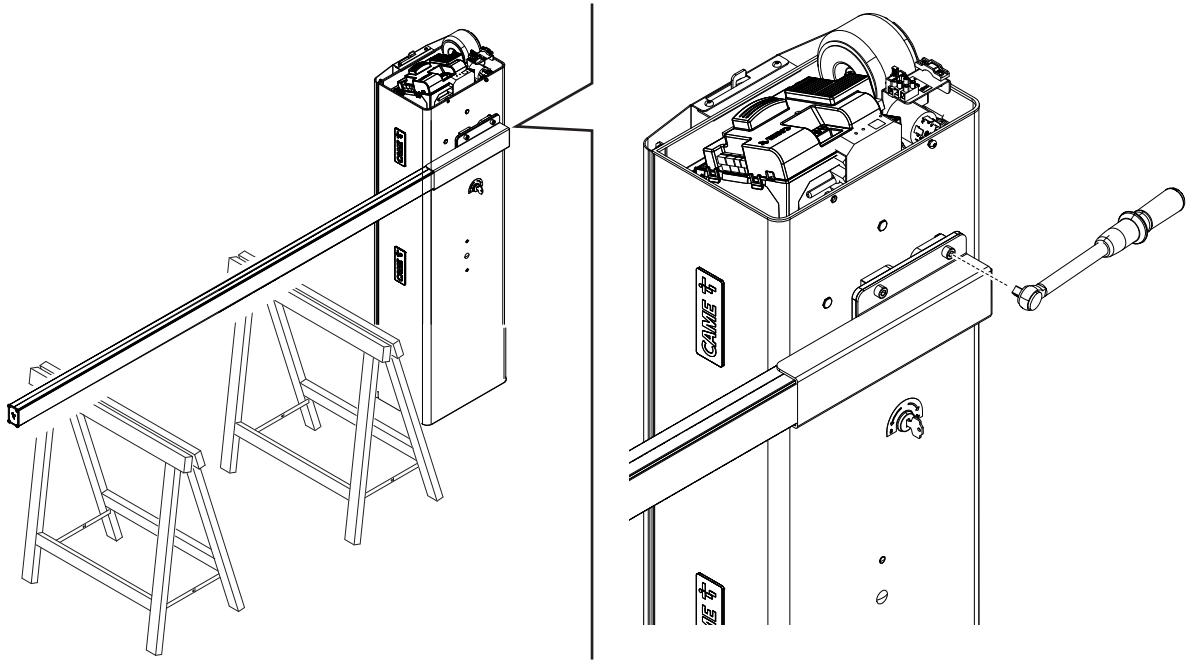

### Choosing the hole for fixing the balance spring

Passage width clearance (m)	2,00 < 2,25	2,25 < 2,75	2,75 < 3,25	3,25 < 3,50	3,50 < 3,75	3,75 < 4,00
Boom	-	1	1	1	2	2
Boom with anti-collision profile and LED strips	1	1	2	2	3	3
Boom with single skirt	1	2	3	3	-	-
Boom with swing rest	2	2	2	3	3	-
Boom with anti-collision profile and swing rest	2	2	3	-	-	-

If the passage is wider than 3 m, you must use a support for the boom (fixed or mobile).

Single skirt (803XA-0340):

- max 2 modules for a 4 metre boom

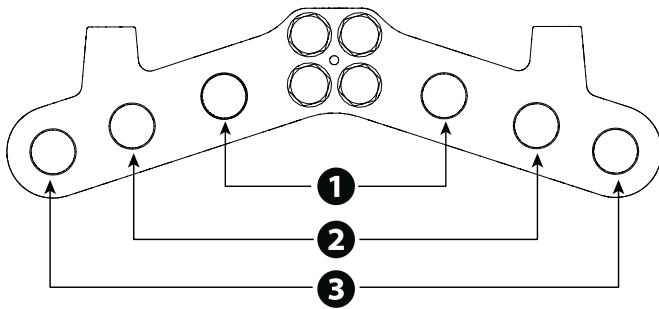



## Assembling the balance spring

- ① Hex-head screw M12 x 120
- ② Top spring attachment
- ③ Bushing Ø13.8
- ④ Washer M8
- ⑤ Hex-head screw M8 x 35
- ⑥ Bushing Ø19
- ⑦ M8 self-locking nut
- ⑧ M12 nut

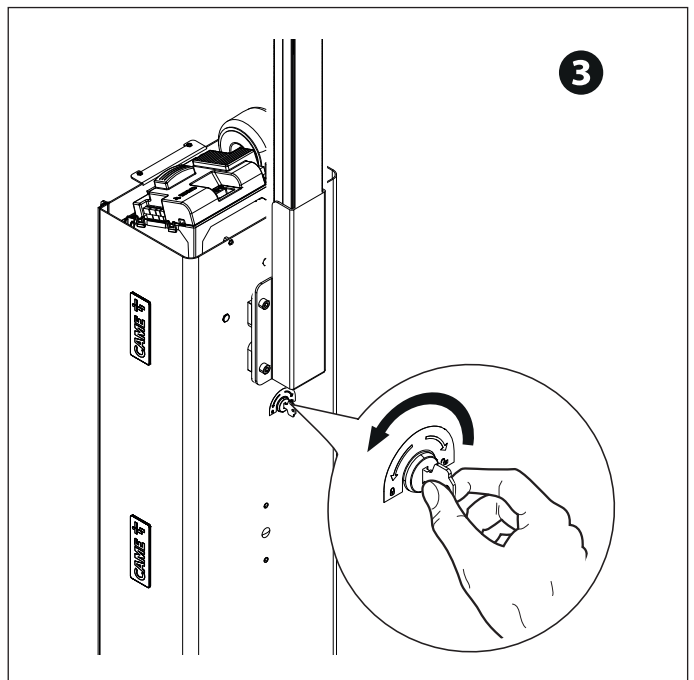
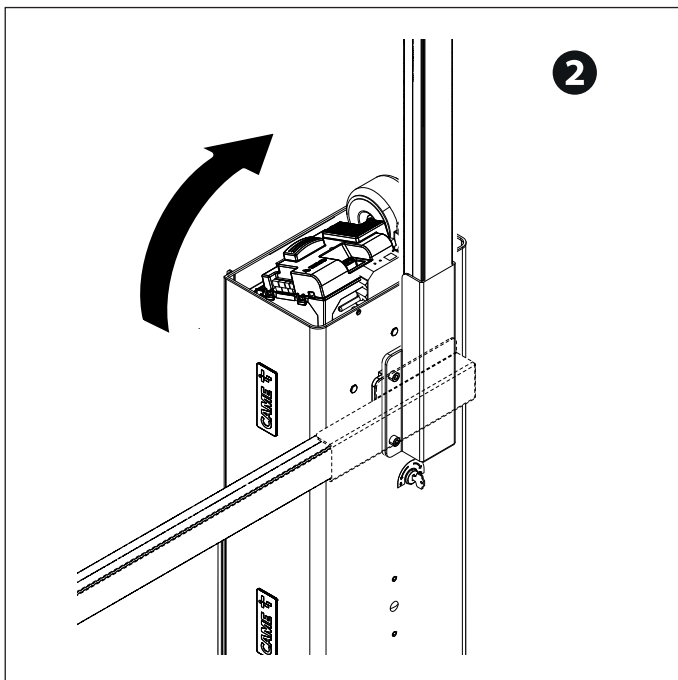
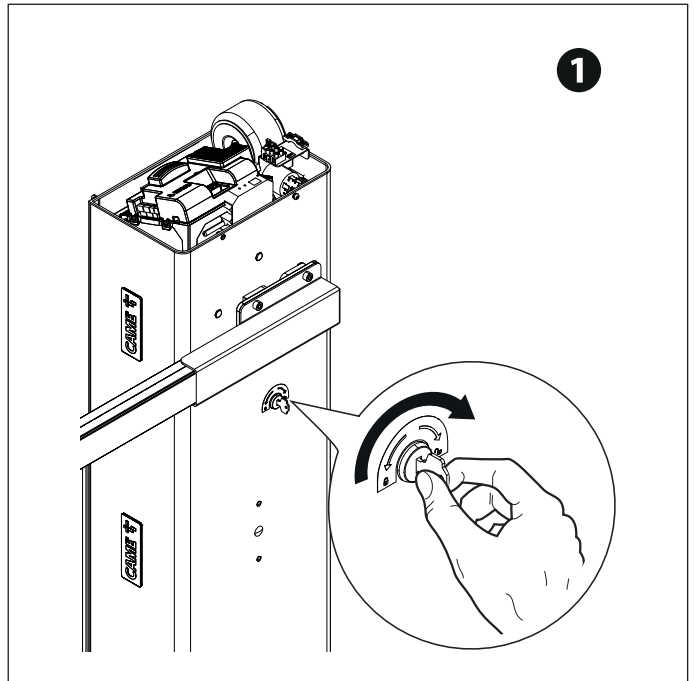
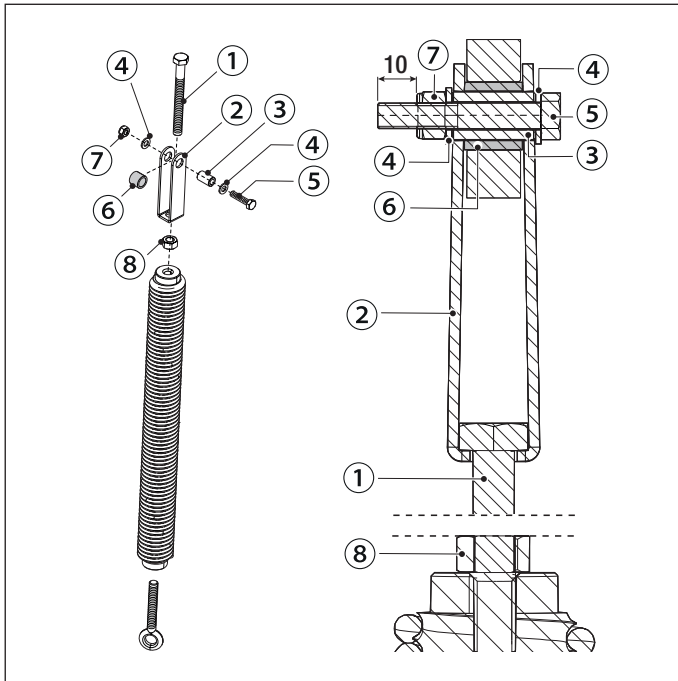
- ① Release the gearmotor.
- ② Position the boom vertically.
- ③ Lock the gearmotor.
- ④ ⑤ ⑥ Assemble the anchoring pin and fix it on the lever arm.
- ⑦ Tighten the eyelet tie rod to the lower part of the spring.
- ⑧ Screw the spring to the anchoring pin.
- ⑨ Hook the eyelet rod onto the anchoring bracket.

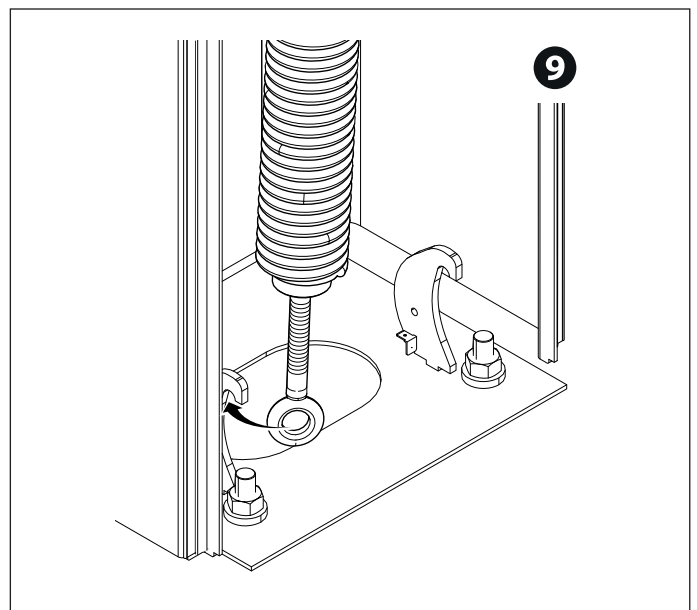
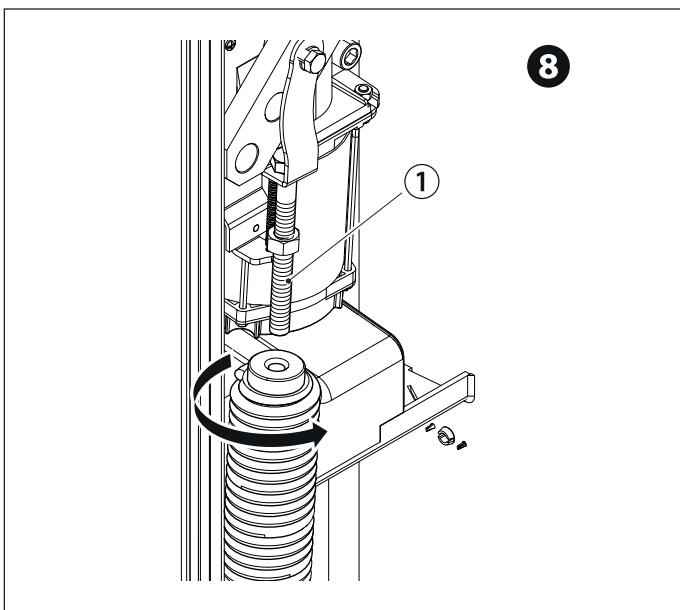
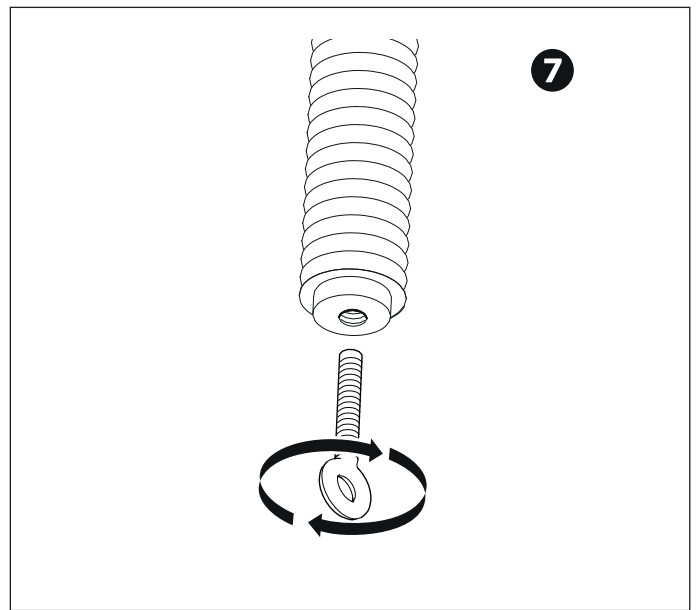
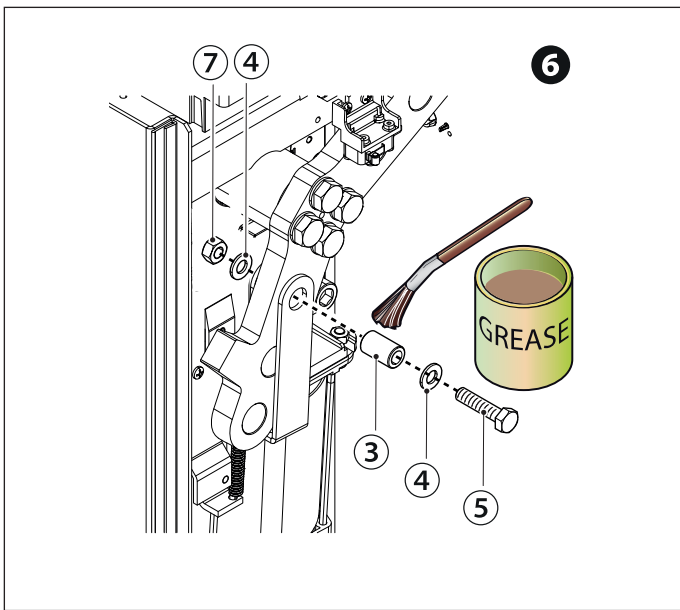
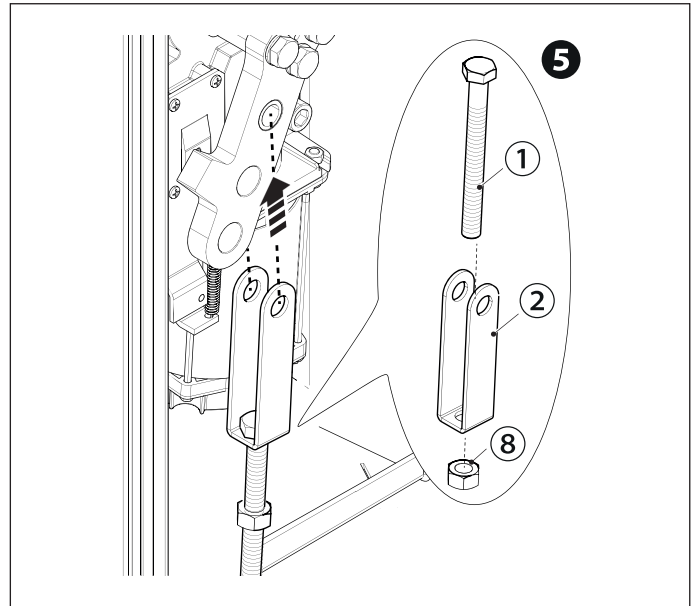
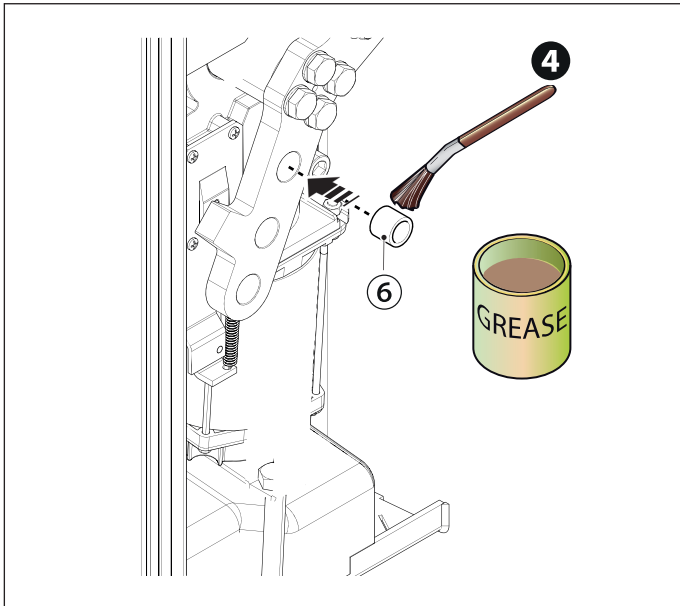



 Lubricate the spring when it is fully extended.

## Balancing the boom

- 1 Release the gearmotor.
- 2 Manually turn the spring to increase or reduce the traction. The boom should stabilise at 45°.
- 3 Fasten the locknut.  
Position the boom vertically.

- 4 Lock the gearmotor  
 Check the proper working state of the spring. When the boom is vertical, the spring is not taut. When the boom is horizontal, the spring is taut.

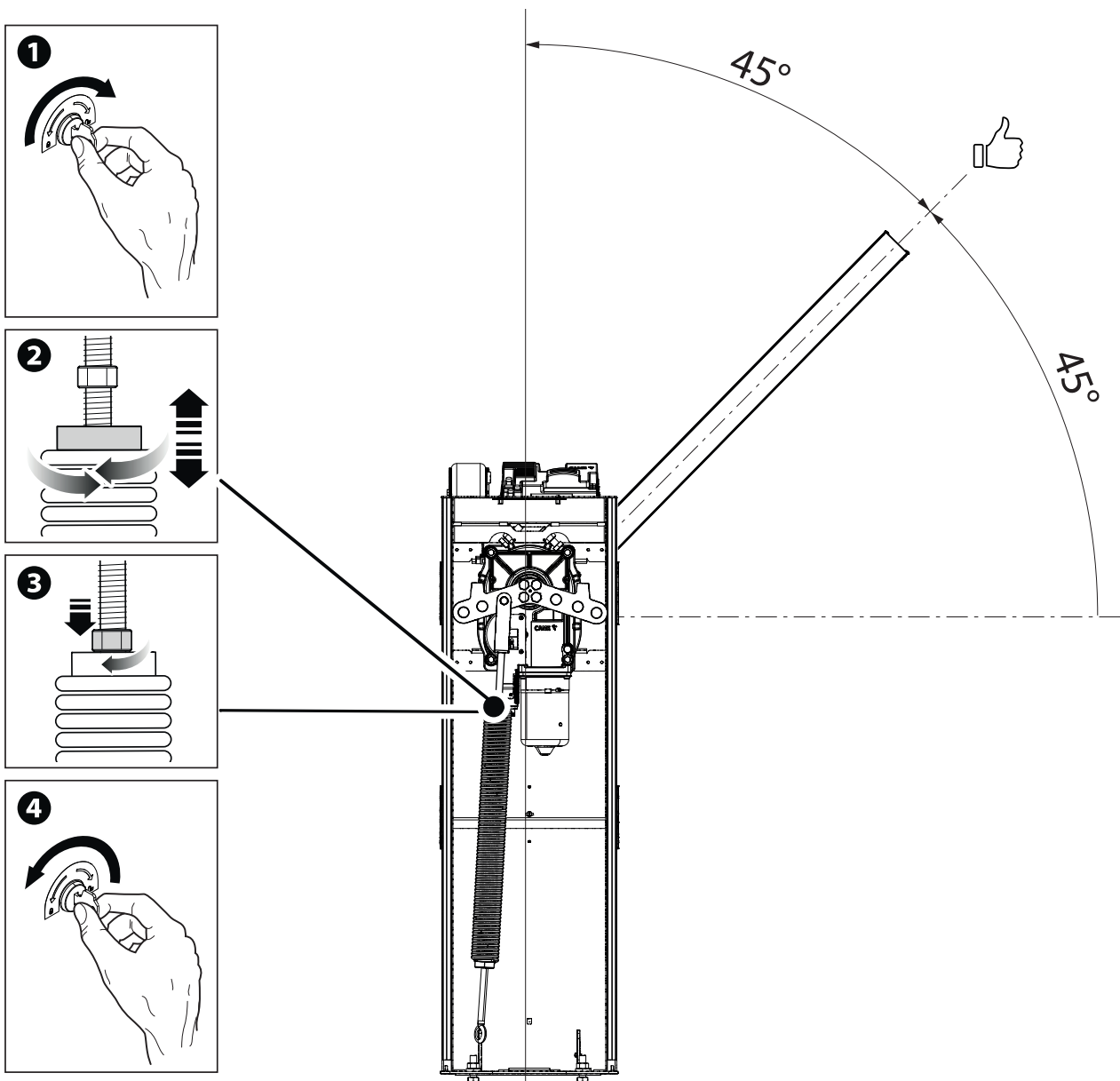

## Determining the travel end points with mechanical limit switches

Check that the boom is parallel to the road surface when it is in the closed position and at about 89° when it is in the open position.

### Correct the boom's horizontal position

Release the gearmotor.

Open the inspection hatch.

- 1 Turn the mechanical stop until you reach the desired boom position.
- 2 Fasten the mechanical stop with a locknut.

Lock the gearmotor

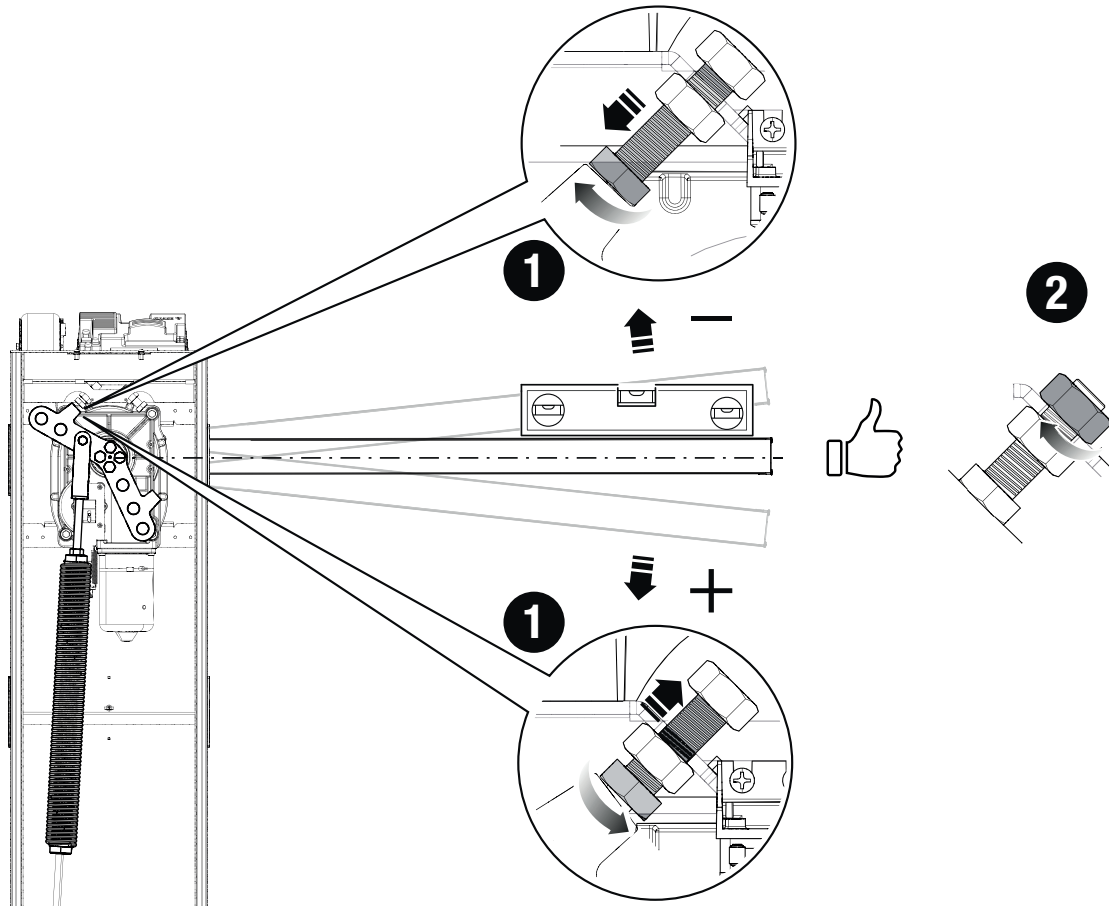

## Correct the boom's vertical position

Release the gearmotor.

Open the inspection hatch.

➊ Turn the mechanical stop until you reach the desired boom position.

➋ Fasten the mechanical stop with a locknut.

Lock the gearmotor

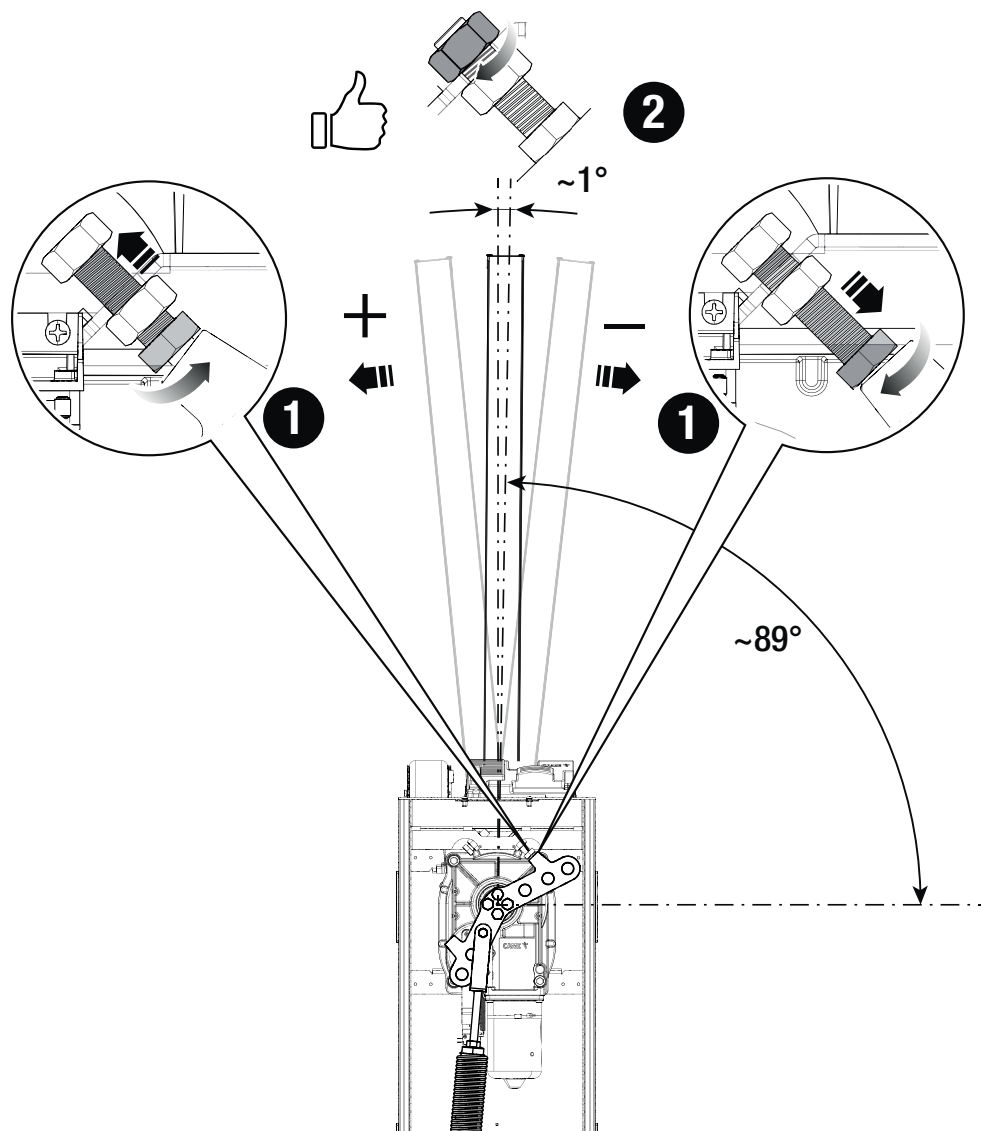

**Passing the electrical cables**

Connect all wires and cables in compliance with the law.

The electrical cables must not touch any parts that may overheat during use (such as the motor and transformer).

Make sure that the moving mechanical parts are suitably far away from the wiring.

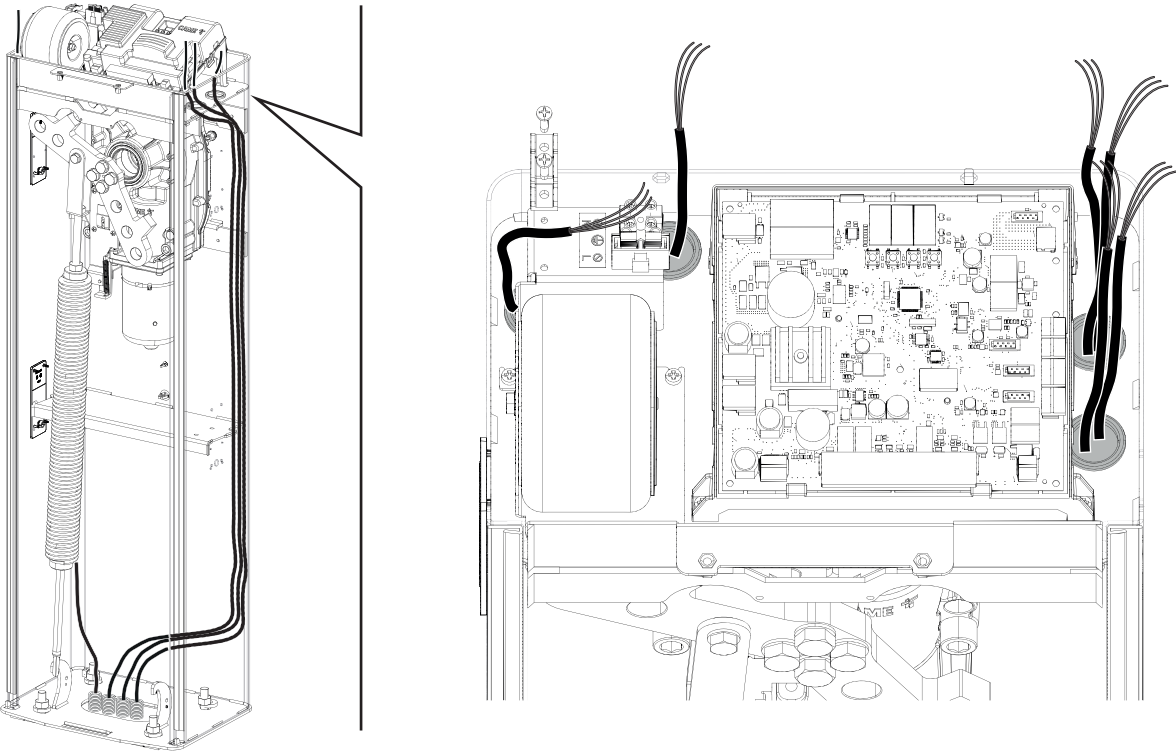

**Power supply**

Make sure the mains power supply is disconnected during all installation procedures.

Before working on the control panel, disconnect the mains power supply and remove the batteries, if any.

**Connecting to the electrical network**

- Line fuse
- Phase wire
- Neutral wire
- Earth wire

**Power supply output for accessories**

The output normally delivers 24 V AC.

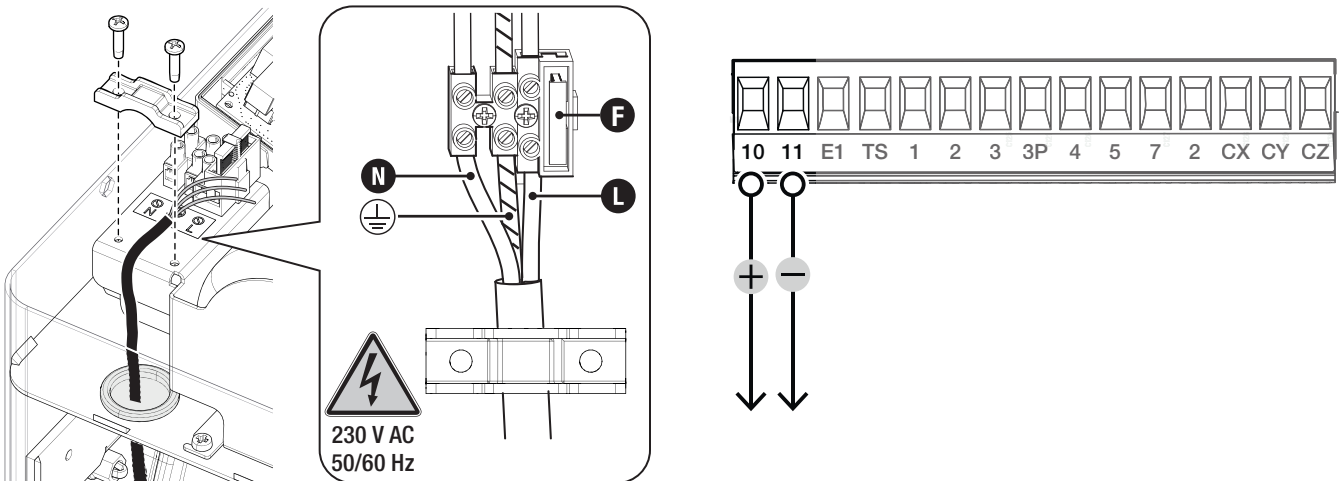

## Maximum capacity of contacts

The total power of the outputs listed below must not exceed the maximum output power [Accessories]

Device	Output	Power supply (V)	Maximum power (W)
Accessories	10 - 11	24 AC	40
Flashing beacon	10 - E1	24 AC	15
Passage-open warning light	10 - 5	24 AC	3

The outputs deliver 24 V DC when the batteries start operating, if they are installed.

## Command and control devices

### 1 STOP button (NC contact)

This stops the boom and excludes automatic closing. Use a control device to resume movement.

If the contact is not used, it must be deactivated during programming.

### 2 Control device (NO contact)

OPEN ONLY function

When the [HOLD-TO-RUN] function is active, the control device must be connected during OPENING.

### 3 Control device (NO contact)

PARTIAL OPENING function

The contact must only be used for operators working in paired mode.

### 4 Control device (NO contact)

CLOSE ONLY function

When the [HOLD-TO-RUN] function is active, the control device must be connected during CLOSING.

### 5 Control device (NO contact)

OPEN-CLOSE function

### 6 Card reader

Insert the R700 card into the corresponding connector.

### 7 Transponder selector switch

Insert the R700 card into the corresponding connector.

### 8 Keypad selector

Insert the R800 card into the corresponding connector.

### 9 Antenna with RG58 cable

Insert the AF card into the corresponding connector for remote control with transmitter.

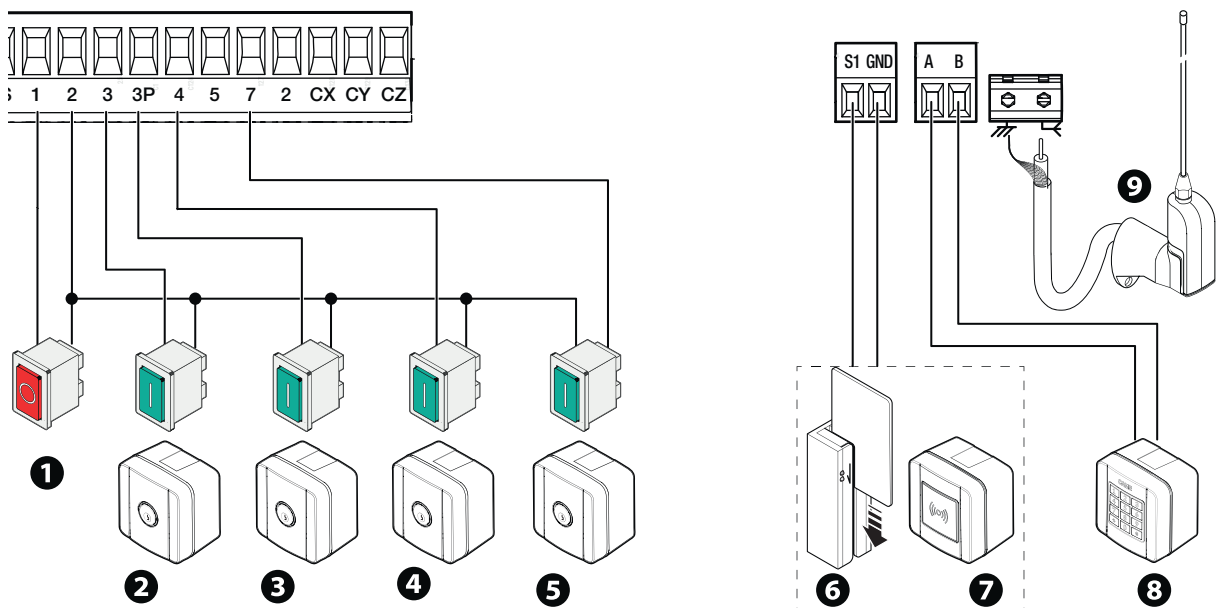



## Signalling devices

### 1 Additional light

It increases the light in the manoeuvring area.

See function [F18].

### 2 Additional flashing beacon

It flashes when the operator opens and closes.

See function [F18].

### 3 Operator status warning light

It notifies the user of the operator status.

See function [F10].

### 4 LED strip

See function [F15].

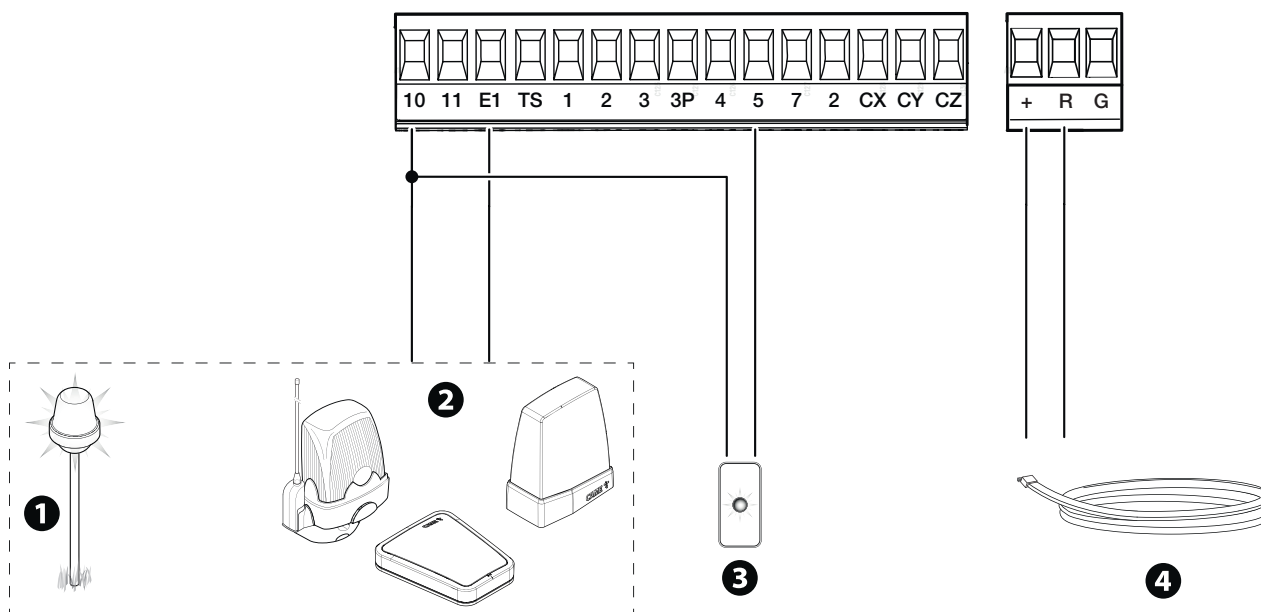

## Safety devices

Connect the safety devices to the CX, CY and/or CZ inputs (NC contacts).

During programming, configure the type of action that must be performed by the device connected to the input.

If contacts CX, CY and CZ are not used, they must be deactivated during programming.

### DELTA photocells

Standard connection

Multiple photocell pairs can be connected.

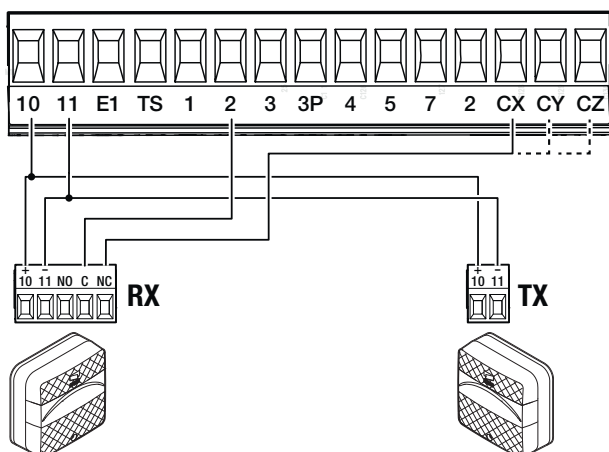

### DELTA photocells

Connection with safety test

Multiple photocell pairs can be connected.

See function [F5] Safety devices test.

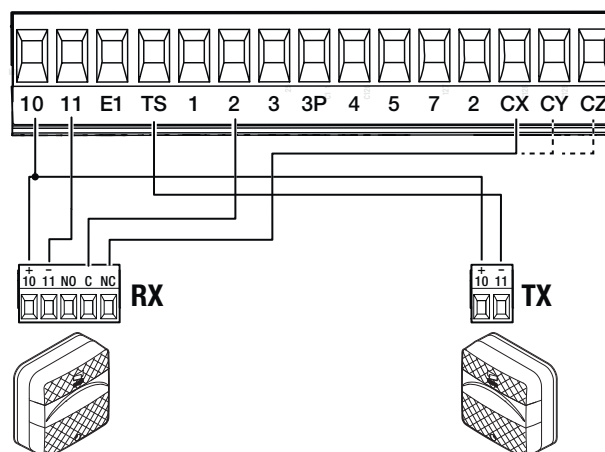

### DIR / DELTA-S photocells

Standard connection

Multiple photocell pairs can be connected.

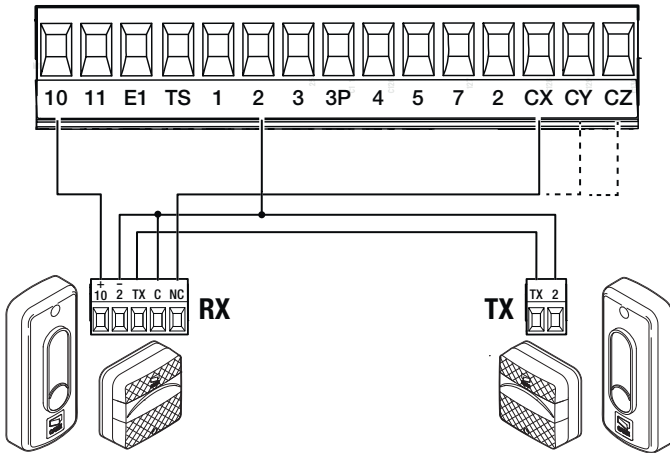

### DIR / DELTA-S photocells

Connection with safety test

Multiple photocell pairs can be connected.

See function [F5] Safety devices test.

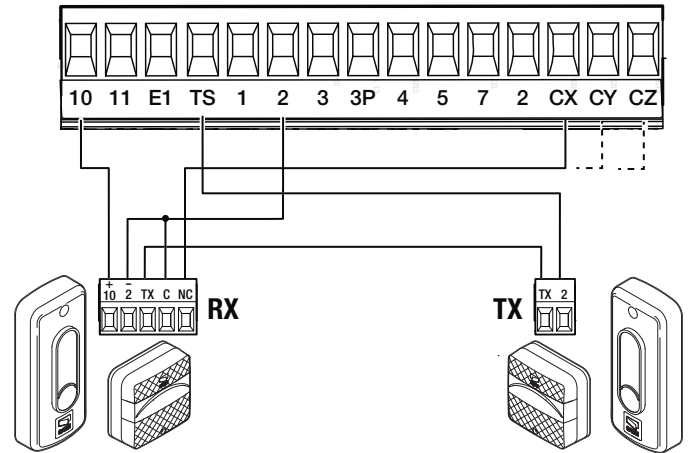

### DXR/DLX photocells

Standard connection

Multiple photocell pairs can be connected.

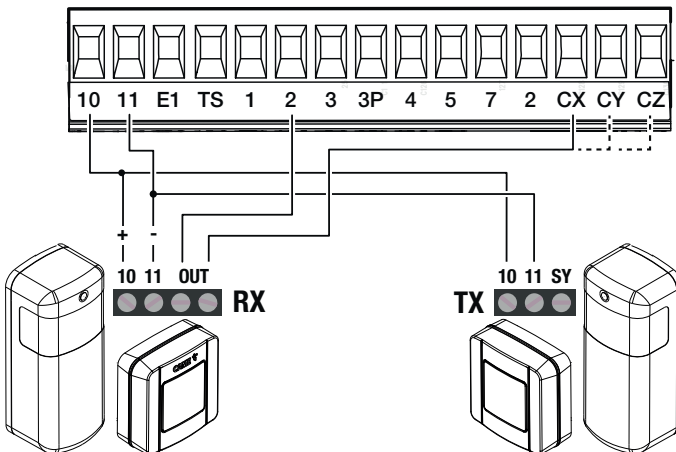

### DXR/DLX photocells

Connection with safety test

Multiple photocell pairs can be connected.

See function [F5] Safety devices test.

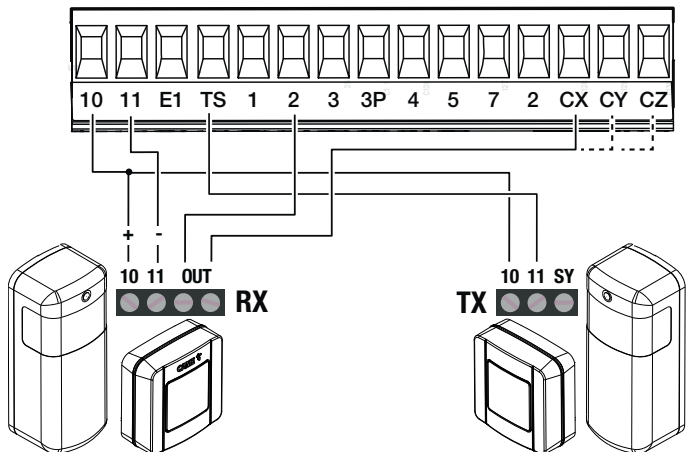

Programming button functions

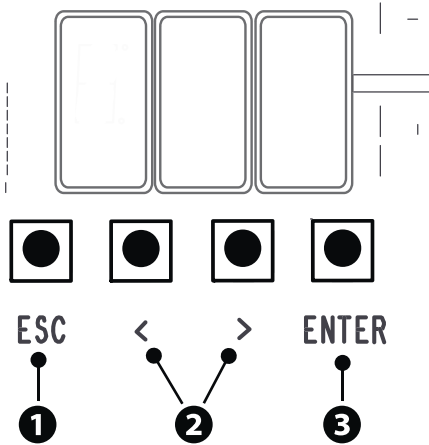

1 ESC button

The ESC button is used to perform the operations described below.  
 Exit the menu  
 Delete the changes  
 Go back to the previous screen

2 <> buttons

The <> buttons are used to perform the operations described below.  
 Navigate the menu  
 Increase or decrease values

3 ENTER button

The ENTER button is used to perform the operations described below.  
 Access menus  
 Confirm choice

During movement, outside the menu, the ESC key stops the barrier and the <> keys open and close the barrier.

Getting started

Once the electrical connections have been made, proceed with commissioning. Only skilled and qualified staff may perform this operation.

Check the warning and safety devices are working properly.

Make sure that there are no obstacles in the way.

Power up and proceed with the operations indicated below.

A1 Boom length

F54 Opening direction

A2 Motor test

F1 Total stop

A3 Travel calibration

After powering up the system, the first manoeuvre is always to open the gate. Wait for the manoeuvre to be completed.

Press the ESC button or STOP button immediately in the event of any faults, malfunctions, strange noises or vibrations, or unexpected behaviour in the system.

If "A3" scrolls across the display, this means that the electronic board has not yet been calibrated.

At the end of commissioning, check the correct operation of the device using the buttons near the display. Check that the accessories also work correctly.

Functions menu

Total stop

This stops the boom and excludes automatic closing. Use a control device to resume movement.

F1	OFF (Default) ON
----	---------------------

CX input

Associate a function with the CX input.

F2	OFF (Default) C1 = Reopen while closing (photocells) C4 = Obstacle standby (photocells) C5 = Immediate closure at the travel end during opening C7 = Reopen while closing (sensitive edges) C9 = Immediate closure at the travel end during opening with obstacle standby during closure C10 = Immediate closure during opening with obstacle standby during closure (NO contact) C11 = Immediate closure during opening with obstacle standby during closure (NC contact) C13 = Reopen while closing, with immediate closure once the obstruction has been removed, even if the boom is not in motion r7 = Reopen while closing (sensitive edges with 8K2 resistor)
----	---

## CY input

Associate a function with the CY input.

<b>F3</b>	OFF (Default) C1 = Reopen while closing (photocells) C4 = Obstacle standby (photocells) C5 = Immediate closure at the travel end during opening C7 = Reopen while closing (sensitive edges) C9 = Immediate closure at the travel end during opening with obstacle standby during closure C10 = Immediate closure during opening with obstacle standby during closure (NO contact) C11 = Immediate closure during opening with obstacle standby during closure (NC contact) C13 = Reopen while closing, with immediate closure once the obstruction has been removed, even if the boom is not in motion r7 = Reopen while closing (sensitive edges with 8K2 resistor)
-----------	---

## CZ input

Associate a function with the CZ input.

<b>F4</b>	OFF (Default) C1 = Reopen while closing (photocells) C4 = Obstacle standby (photocells) C5 = Immediate closure at the travel end during opening C7 = Reopen while closing (sensitive edges) C9 = Immediate closure at the travel end during opening with obstacle standby during closure C10 = Immediate closure during opening with obstacle standby during closure (NO contact) C11 = Immediate closure during opening with obstacle standby during closure (NC contact) C13 = Reopen while closing, with immediate closure once the obstruction has been removed, even if the boom is not in motion r7 = Reopen while closing (sensitive edges with 8K2 resistor)
-----------	---

## Safety devices test

Check that the photocells connected to the inputs are operating correctly, after each opening and closing command.

<b>F5</b>	OFF (Default) 1 = CX 2 = CY 3 = CX+CY 4 = CZ 5 = CX+CZ 6 = CY+CZ 7 = CX+CY+CZ
-----------	--

## Hold-to-run

With the function active, the operator stops moving (opening or closing) when the control device is released.

 When the function is active, it excludes all other control devices.

<b>F6</b>	OFF (Default) ON
-----------	---------------------

## Obstacle with motor stopped

With the function active and the operator stopped, an open or close command is not performed if the safety devices detect an obstacle.

<b>F9</b>	OFF (Default) ON
-----------	---------------------

## Open warning light

Barrier status signal.

The device is connected to output 10-5.

<b>F10</b>	0 = Warning light on (default) - The light stays on when the boom is moving or open. 1 = Warning light flashing - The warning light flashes every half a second when the boom is opening and remains on when the boom is open. The light flashes every second when the boom is closing, and remains off when the boom is closed.
------------	---

### Sensor type

Choose the type of access device.

F14

1 = Keypad (Default)  
0 = Transponder

### LED strip light management

Choose the operating mode for the LED strip light.

F15

0 = bi-colour LED strip light (default)  
1 = White LED strip light

### Light E1

Choose the type of device connected to output E1.

F18

0 =Flashing beacon (Default)  
1 = Cycle light  
The lamp stays on during the manoeuvre.  
 This parameter does not appear if there [Automatic Close] function is deactivated.  
2 = Courtesy lamp  
The light switches on when a manoeuvre starts and remains on once the manoeuvre has finished, for the time set under the function [F25 Courtesy time].

### Automatic closure

Set the time before automatic closure is activated, once the opening travel end point has been reached.

 The function does not work if any of the safety devices are triggered when an obstacle is detected, or after a complete stop, or during a power outage.

F19

OFF (Default)  
From 1 to 180 seconds

### Pre-flashing time

Set the time for which the beacon is activated before each manoeuvre.

F21

OFF (Default)  
1 to 10 seconds

### Courtesy time

Set the lighting device operation time.

F25

60 to 180 seconds (Default 180 seconds)

### Opening speed

Set the opening speed as a percentage.

 For booms complete with accessories (swing rest and/or skirt), reduce the speed.

F28

50% to 100% (Default 70%)

### Closing speed

Set the closing speed (percentage of maximum speed).

 For booms complete with accessories (swing rest and/or skirt), reduce the speed.

F29

from 30% to 100% (Default 50%)

### Travel sensitivity

Adjust the obstruction detection sensitivity during boom travel.

<b>F34</b>	10% to 100% (Default 100%)  10% = minimum thrust and high obstruction sensitivity 100 % =maximum thrust and low obstruction sensitivity
------------	--

### RSE

Configure the connector connections on RSE1 and RSE2.

If an RSE card – configured for paired connections – is plugged into the RSE\_1 connector, use the RSE\_2 connector for remote connection (CRP). In this case, a CAME KEY cannot be connected.

<b>F49</b>	<b>rE1</b> 1 = Paired 3 = CRP/CAME KEY (Default) 4 = Alternate	<b>rE2</b> 3 = CRP/CAME KEY (Default) 5 = I/O - RS485 6 = ModBus
------------	---	---

### Save data

Save user data, timings and configurations to a memory device (memory roll or USB key).

 The function is displayed only when a USB stick is inserted into the USB port or a memory roll card is inserted into the control board.

<b>F50</b>	OFF (Default) ON (Run operation)
------------	-------------------------------------

### Read data

Load user data, timings and configurations from a memory device (memory roll or USB key).

 The function is displayed only when a USB stick is inserted into the USB port or a memory roll card is inserted into the control board.

Upload user data, timings and configurations from the memory device (memory roll or USB key).

<b>F51</b>	OFF (Default) ON (Run operation)
------------	-------------------------------------

### Transferring MASTER-SLAVE parameters

Share parameters programmed on the Master barrier with the Slave barrier.

 This only appears if the F49 function is set to [Paired] or [Alternate].

<b>F52</b>	OFF (Default) ON
------------	---------------------

### Opening direction

Set the boom-opening direction.

<b>F54</b>	0 = To the left (default) 1 = To the right
------------	---

### CRP address

Assign a unique identification code (CRP address) to the control board.

<b>F56</b>	1 to 254
------------	----------

### Configure maintenance

Set the number of manoeuvres the operator can perform before a maintenance warning signal is generated.

 The warning is displayed as an [SEr] message and signalled by 3 + 3 flashes every hour on the device connected to the 10-5 output.

<b>F58</b>	OFF (Default) 1 to 999 (1 = 1000 manoeuvres)
------------	---

### Pre-flashing

Choose the type of manoeuvre that activates the flashing beacon in advance.

 Set how much earlier the flashing beacon is activated under the function [Pre-flashing time].

<b>F61</b>	0 = when opening and closing (Default) 1 = only when closing 2 = only when opening
------------	--

### RSE speed

Set the communication speed of the remote connection system on the RSE\_1 and RSE\_2 ports.

<b>F63</b>	<b>rE1</b>	<b>rE2</b>
	2 = 4800 bps	2 = 4800 bps
	3 = 9600 bps	3 = 9600 bps
	4 = 14400 bps	4 = 14400 bps
	5 = 19200 bps	5 = 19200 bps
	6 = 38400 bps (default)	6 = 38400 bps (default)
	7 = 57600 bps	7 = 57600 bps
	8 = 115200 bps	8 = 115200 bps

### Opening counter

With the function active, you can send a series of opening commands corresponding to the number of vehicles which have to be authorised to pass through the gate. The function can only be operated by control devices connected to the contact 2-3. The magnetic contact, to which the loop that counts vehicles in transit is connected, is connected to an input. This input must be programmed to operate in C5/C9/C10 mode. At the end of the count the passage is closed.

<b>F75</b>	OFF (Default) ON
------------	---------------------

### Emergency battery operation

Emergency function in the event of a power outage. Batteries required.

<b>F93</b>	OFF (Default) 1 = Immediate opening In the event of a power outage, the operator runs an opening command within 1 minute and all other commands are blocked until power is restored.
------------	--

### New user

Register up to a maximum of 250 users and assign a function to each one.

 The operation can be carried out by using a transmitter or another control device. The boards that manage the control devices (AF - R700 - R800) must be inserted into the connectors.

<b>U1</b>	1 = Step-by-step 2 = Sequential 3 = Open 4 = Partial opening  When the barrier is in [Paired] mode, the [Partial Opening] command opens the Master barrier.  Choose the function to be assigned to the user. Press ENTER to confirm. The free position in the memory is shown intermittently for a maximum of 10 seconds. During this phase, send the code from the control device. Repeat the procedure to add other users.
-----------	--

### Remove user

Remove one of the registered users.

<b>U2</b>	OFF (Default) ON No. 1 > 250 Use the arrows to choose the number associated with the user you want to remove. Alternatively, the control device associated with the user you want to remove can be activated. Press ENTER to confirm.  "CLR" will appear to confirm deletion.
-----------	--

### Remove all

Remove all registered users.

<b>U3</b>	OFF (Default) ON
-----------	---------------------

### Radio decoding

Choose the type of radio coding for the transmitters enabled to control the operator.

 If you choose the type of radio coding for the transmitters [Rolling code] or [TW key block], any transmitters with a different type of radio coding saved previously will be deleted.

<b>U4</b>	1 = All decoding (default) 2 = Rolling code 3 = TW key block
-----------	--

### Self-Learning Rolling

Save a new rolling code transmitter by activating acquisition from a rolling code transmitter that has already been saved. The saving and acquisition procedures are explained in the transmitter manual.

<b>U8</b>	OFF (Default) ON
-----------	---------------------

### Boom length

Set the boom length.

<b>A1</b>	3 = 3 m boom 4 = 4 m boom
-----------	------------------------------

### Motor test

Check the boom opens in the correct direction.

 If the keys do not execute the commands correctly, invert the boom opening direction.

<b>A2</b>	The button > makes the motor turn in clockwise direction. The button < makes the motor turn in an anticlockwise direction.
-----------	---

### Travel calibration

Start the travel self-learning.

<b>A3</b>	ON (Run operation) OFF (Cancel operation)
-----------	--

### Parameter reset

Restore factory settings except for the functions: [Radio decoding], [Boom length] and the settings related to travel calibration.

<b>A4</b>	OFF (Default) ON
-----------	---------------------



### Manoeuvre counter

View the number of total or partial operator manoeuvres (after maintenance).

The number of manoeuvres is the number shown multiplied by 1000.

<b>A5</b>	Tot = total manoeuvres Manoeuvres performed since the operator was installed. Par = partial manoeuvres Under the [Par] parameter, press the ENTER key to reset the number of partial manoeuvres. [Clr] will appear on the screen to confirm deletion.
-----------	--

### FW version

Display the firmware version number.

<b>H1</b>	
-----------	--

### Enable password

Set a 3-digit password. The password will be requested to anyone who wants to access the main menu.

Remove the password that protects access to the main menu.

<b>H3</b>	ON Use the arrows and the Enter button to dial the desired code.	OFF Press ENTER to confirm deletion.
-----------	---	---

### Forgotten password

If you forget your password, follow the procedure below.

Disconnect the control board from the power supply.

Press and hold the < and > buttons, then reconnect the control board to the power supply.

Continue to press and hold the < > buttons until [ON/OFF] is displayed.

Select [ON].

Press ENTER to confirm.

When you reset the control board, all saved users, set times and calibration operations are deleted.

### Import/export data

**1** Insert the MEMORY ROLL card into the corresponding connector on the control board.

**2** Press the "Enter" button to access programming.

**3** Use the arrows to choose the desired function.

The functions are displayed only when a MEMORY ROLL card is inserted.

-Save data

Save user data, timings and configurations to the memory device (memory roll or USB key).

-Read data

Upload user data, timings and configurations from the memory device (memory roll or USB key).

Before inserting and removing the MEMORY ROLL card, DISCONNECT THE MAINS POWER SUPPLY TO THE LINE.

Remove the MEMORY ROLL card after the data has been loaded.

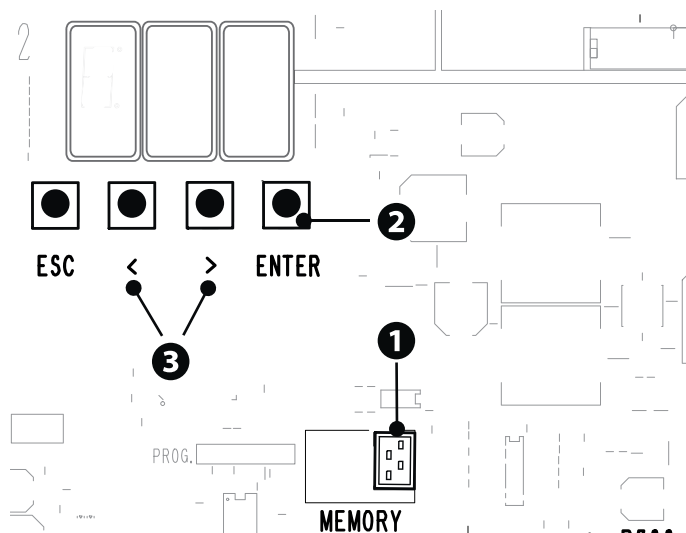

## FINAL OPERATIONS

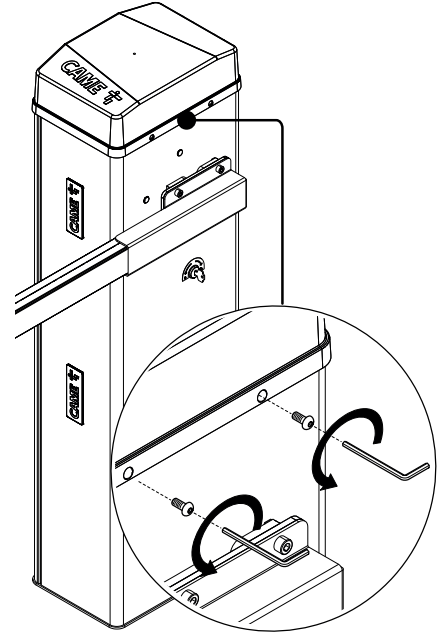
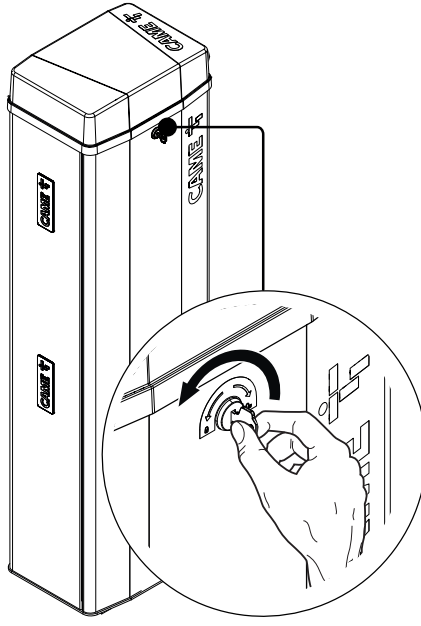
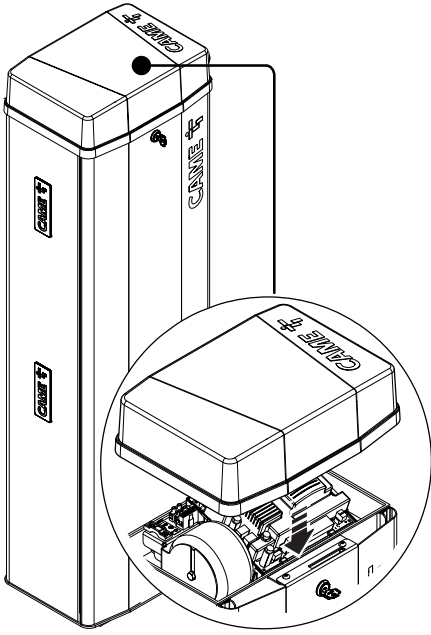
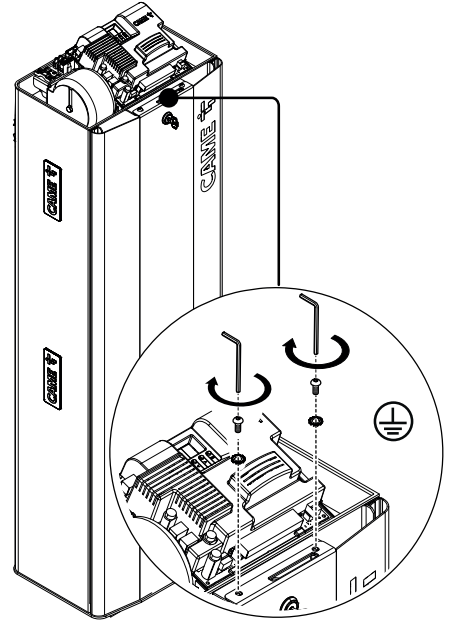
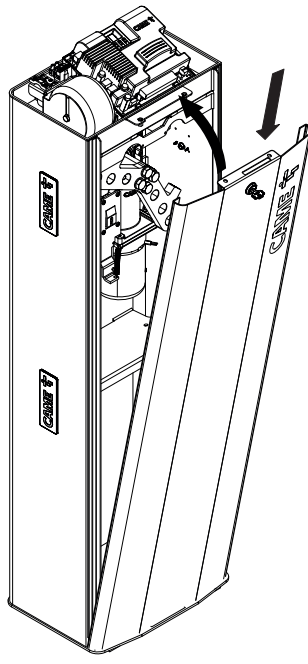
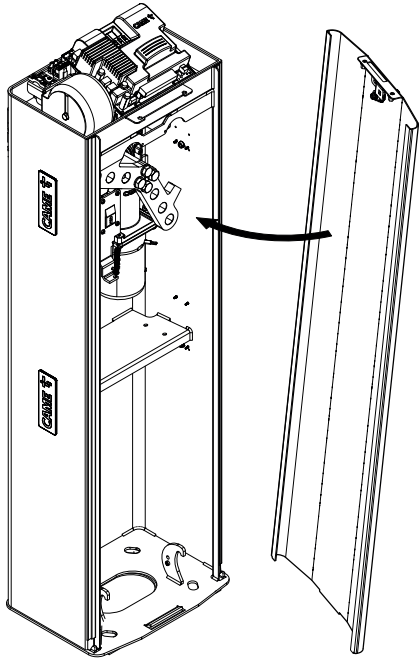

## PAIRED OPERATION

Two connected operators are controlled with one command.

### Electrical connections

Connect the two electronic boards with a UTP CAT 5 cable.

Fit an RSE card on both control boards, using the RSE\_1 connector.

Connect up the electrics for the devices and accessories.

 For information on connecting the electrics for the devices and accessories, please see the “ELECTRICAL CONNECTIONS” section.

 The devices and accessories must be connected to the control board which will be set as the MASTER.

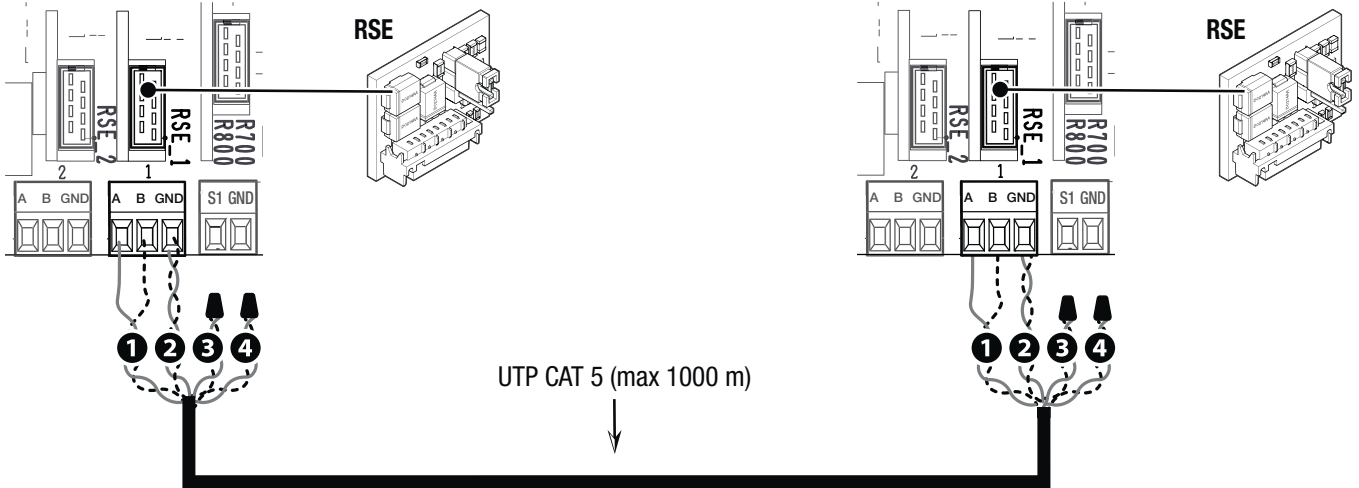

### Programming

 All programming operations described below must be performed only on the control board set as the MASTER.

Configure the RSE\_1 port in [Paired].

Enable the sharing of parameters programmed on the Master barrier with the Slave barrier.

 After programming the MASTER operator in [Paired], the second operator automatically becomes SLAVE.

### Saving users

 All save user operations must be performed only on the control board set as the MASTER.

 For user storage operations, see the [New user] function.

### Operating modes

**1** OPEN-CLOSE command (2-7), OPEN ONLY (2-3) or CLOSE ONLY (2-4)

**2** PARTIAL OPENING command (2-3P)

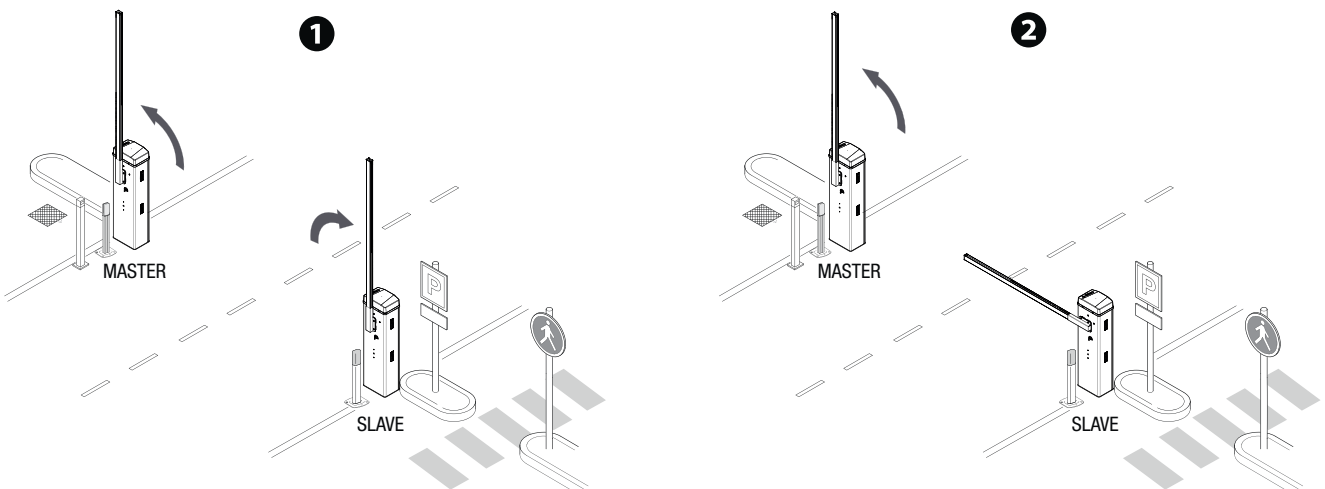

## ALTERNATE OPERATION

The first barrier opens, the vehicle passes, the first barrier closes, the second barrier opens, the vehicle passes and the second barrier closes.

### Electrical connections

Connect the two electronic boards with a UTP CAT 5 cable.

Fit an RSE card on both control boards, using the RSE\_1 connector.

Connect up the electrics for the devices and accessories.

 For information on connecting the electrics for the devices and accessories, please see the "ELECTRICAL CONNECTIONS" section.

 The control and safety devices must be connected on both electronic boards.

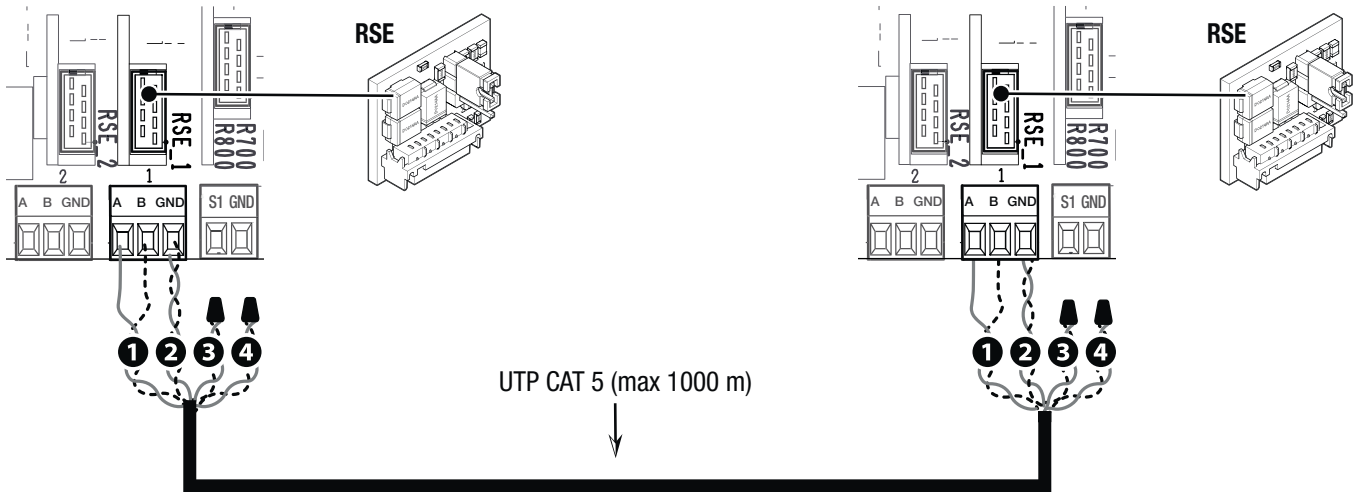

### Programming

On one of the two barriers, configure the [RSE\_1] function in [Alternate].

It activates the function [Automatic close] on both control boards.

### Saving users

 For user storage operations, see the [New user] function.

 When programming users, do not use the PARTIAL OPENING 2-3P command.

### Operating modes

**1** ONLY OPEN command (2-3) on barrier A

**1**

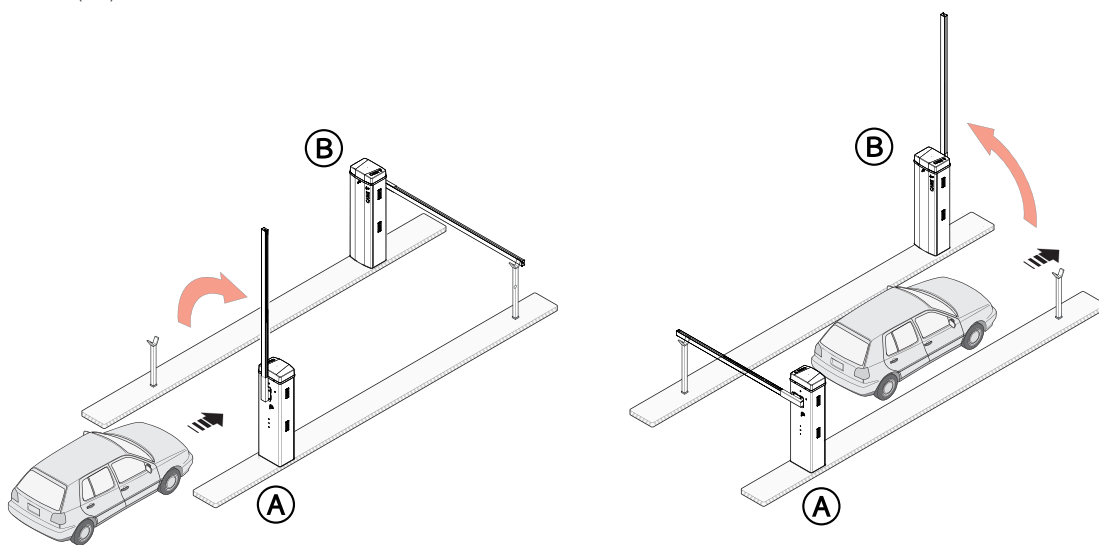

2 ONLY OPEN command (2-3) on barrier B

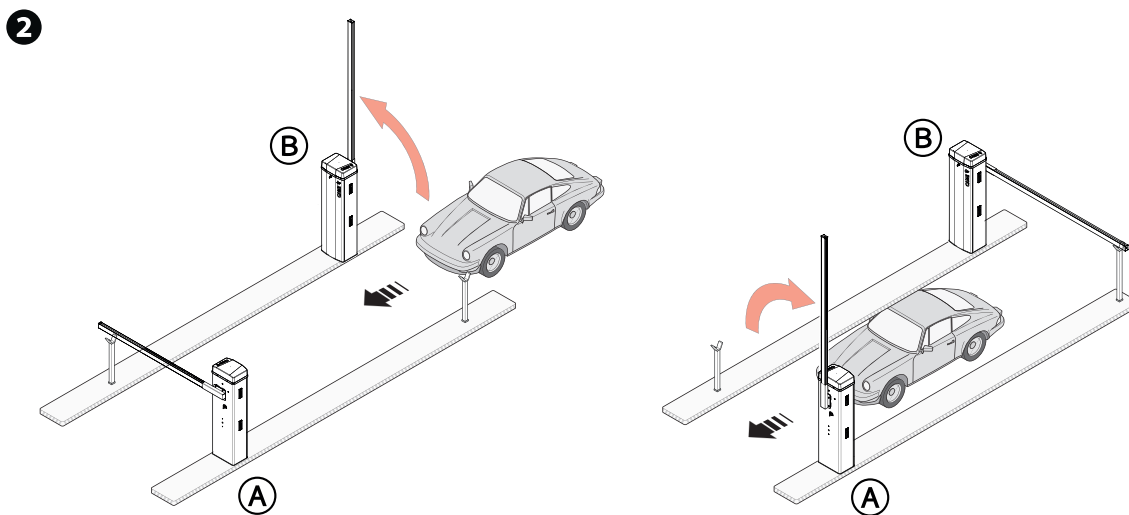

3 OPEN-CLOSE command (2-7) on barrier A or B for emergency opening

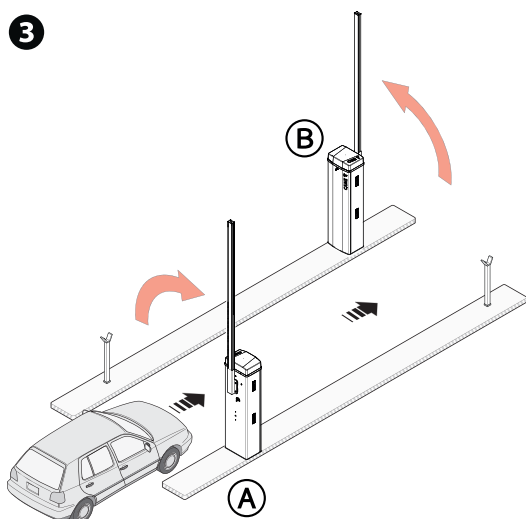

## MCBF

Models	LT/LS
Standard boom L = 4 m	1.500.000
Skirt	-20%
Mobile foot	-20%
Articulated joint	-20%

 The MCBF value relates to the barrier only and does not refer to any applicable accessories.

 The GARD LT barrier has been designed to perform up to 1.5 million cycles. Thanks to its 24V DC motor, it is extremely reliable and requires very little maintenance.

 Before carrying out any cleaning or maintenance, or replacing any parts, disconnect the device from the power supply.

 This document informs the installer of the checks that must be carried out during maintenance.

 If the barrier is not used for long periods of time, e.g. for installations at sites with seasonal closures, release the spring and remove the boom.

 For information on correct installation and adjustments, please see the product installation manual.

 For information on choosing products and accessories, please see our product catalogue.

 If the barrier with an articulated joint is used, check that the moving parts of the joint are in good condition. Replace them if necessary.

Every 250,000 cycles and, in any case, every 6 months of operation, you must perform the maintenance work indicated below.

Perform a general and complete check of the tightness of the nuts and bolts.

Lubricate the spring when it is fully extended.

Check the 45° boom balance and if necessary tension the balance spring, adjusting its traction operating on the hooking tie rods.

Grease all of the moving mechanical parts.

Check the warning and safety devices are working properly.

Check that the microswitch connected to the cabinet hatch is working correctly.

Check the microswitch connected to the manual release is working properly, and the microswitch connected to the release accessories (optional).

Check for any wear on the moving mechanical parts and check that they are working properly.

Check the cables are intact and connected correctly.

Every 1,000,000 cycles and, in any case, every 24 months of operation, you must perform the maintenance work indicated below.

Replace the balance spring.

**ERROR MESSAGES**

<b>E2</b>	Adjustment error
<b>E3</b>	Encoder failure error
<b>E4</b>	Service test failure error
<b>E7</b>	Operating time error
<b>E8</b>	Open release-hatch error
<b>E9</b>	Obstacle detected during closing
<b>E10</b>	Obstacle detected during opening
<b>E11</b>	The maximum number of obstacles detected consecutively has been exceeded
<b>E12</b>	No line voltage
<b>E14</b>	Serial communication error
<b>E15</b>	Incompatible transmitter error
<b>E16</b>	Open SLAVE-motor hatch error

**NOTICES**

<b>C0</b>	Wire contact 1-2 (NC) is open.
<b>i3</b>	The wire contact 2-3 (NO) is closed.
<b>i3P</b>	The wire contact 2-3P (NO) is closed.
<b>i4</b>	The wire contact 2-4 (NO) is closed.
<b>i7</b>	The wire contact 2-7 (NO) is closed.



**CAME** 

**CAME.COM**

**CAME S.P.A.**

Via Martiri della Libertà, 15  
31030 Dosson di Casier  
Treviso – Italy  
Tel. (+39) 0422 4940  
Fax (+39) 0422 4941